

EIFS Council of Canada

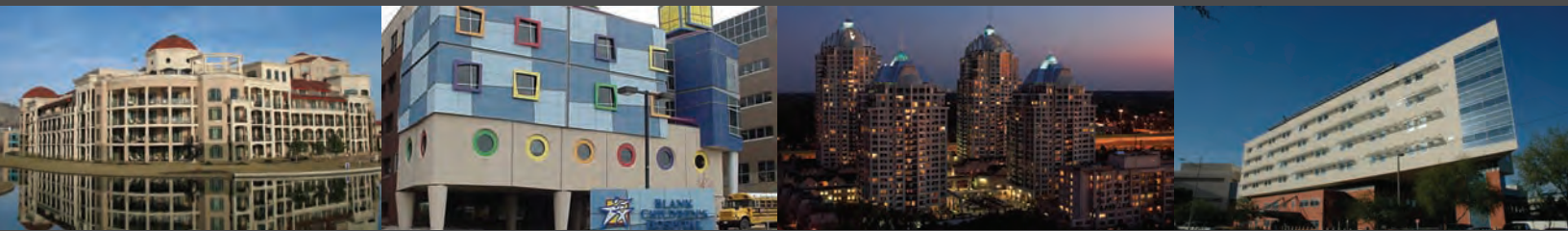

EIFS PRACTICE MANUAL

Version 1.0



EIFS Council of Canada

EIFS

PRACTICE MANUAL

Version 1.0



Table of Contents

Table of Contents	i
FOREWORD.....	i
ACKNOWLEDGEMENTS	ii
DISCLAIMER.....	iii
PREFACE	1
EIFS Standards.....	1
EIFS Quality Assurance Program (QAP).....	2
EIFS Master Specification.....	2
Purpose of This Manual	3
Scope of this Manual.....	3
1. AN INTRODUCTION TO EIFS.....	5
1.1 Description	5
1.2 History.....	7
2. EIFS COMPONENTS.....	8
2.1 Substrate	9
2.1.1 Not Part of the EIFS	9
2.1.2 Structural Adequacy	9
2.1.3 Substrate Condition	10
2.1.4 Mass Wall as an EIFS Substrate.....	12
2.1.5 Framing and Sheathing Boards as an EIFS Substrate	13
2.2 Water Resistive Barrier	17
2.2.1 Material	17
2.2.2 Ability to Bond to the Substrate	18
2.2.3 Ability to Bond to the Adhesive.....	18
2.2.4 Resistance to Water Penetration.....	18
2.2.5 Resistance to Vapour Penetration.....	18
2.2.6 Resistance to UV Radiation.....	19
2.2.7 Nail Pop Resistance	19
2.2.8 Joint Durability.....	19
2.2.9 Application	20
2.2.10 Transition Membranes and Materials	20
2.2.11 Drainage and Flashing.....	21
2.3 Adhesive.....	24
2.4 Insulation.....	26
2.4.1 Material	26
2.4.2 Integral Part of the EIFS.....	26
2.4.3 Thickness.....	27
2.4.4 Application	29
2.4.5 Geometrically Defined Drainage Cavity (GDDC) Insulation	32
2.4.6 Rapping.....	33
2.4.7 Other Considerations.....	34

2.4.8	Aesthetic Reveals	34
2.4.9	Mechanical Fasteners	36
2.5	Base Coat.....	39
2.5.1	Material	39
2.5.2	Bond Strength.....	39
2.5.3	Application	39
2.6	Reinforcing Mesh.....	41
2.6.1	Materials.....	41
2.6.2	Strength and Alkalinity Resistance.....	41
2.6.3	Installation	41
2.7	Finish Coat	45
2.7.1	Materials.....	45
2.7.2	Bond Strength.....	49
2.7.3	Colour Retention	49
2.7.4	Colour Primers.....	49
2.7.5	Mould and Fungus Resistance.....	50
2.7.6	UV Resistance	50
2.7.7	Application	50
2.8	Lamina.....	52
2.8.1	Water Vapour Permeance.....	52
2.8.2	Salt Spray Resistance	52
2.8.3	Resistance to UV Radiation.....	52
2.8.4	Durability Under Environmental Cycling	53
2.9	Terminations and Wrapping.....	58
2.10	EIFS Mouldings	62
2.10.1	Design Considerations.....	65
2.10.2	Installation	68
3.	CLADDING DESIGN USING EIFS	70
3.1	Fire Safety	70
3.1.1	Buildings Allowed to be of Combustible Construction.....	70
3.1.2	Buildings Required to be of Noncombustible Construction.....	70
3.1.3	Limitations on Insulation Thickness.....	72
3.1.4	Protecting Interior Space from Foamed Plastic Insulation.....	72
3.2	Resistance to Rainwater Penetration	74
3.2.1	History.....	74
3.2.2	Current Practice	74
3.2.3	Pressure Moderated EIFS	76
3.2.4	Overhangs.....	76
3.3	Expansion Joints.....	78
3.3.1	Expansion Joint Sealant.....	79
3.3.2	Sealant Compatibility, Adhesion and Sealant Primers	79
3.3.3	Sealant Installation	80
3.3.4	Two-Stage Sealant Joints	81
3.3.5	Two-Stage Joints – Sealant and WRB System Method.....	82

WRB System - Transition Flashings	84
3.4 Air and Vapour Control.....	86
3.4.1 Vapour Control.....	86
3.4.2 Air Leakage Control.....	87
3.5 Impact Resistance.....	88
3.6 Retrofit.....	89
4. SAMPLE EIFS INSTALLATION CHECKLIST	91
5. GLOSSARY	96
6. REFERENCES	99
APPENDIX A: Illustrations 1-25.....	101
1. EIFS Standard Wall Construction.....	102
2. Window Head (Window Installed after WRB)	103
3. Window Head (Window Installed before WRB).....	104
4. Window Sill, Option A (Membrane/Metal Flashing Combination to Create Sub-Sill)	105
5. Window Sill, Option B (Membrane Sub-Sill).....	106
6. Window Sill, Option C (EIFS Installed After the Window).....	107
7. Window Jamb (Transition Material at Rough Opening).....	108
8. Window Jamb (Transition WRB Material at Rough Opening and Transition Membrane Onto Frame	109
9. Window Opening Treatment	110
10. Horizontal Expansion Joint.....	111
11. Horizontal Drained Expansion Joint	112
12. Vertical Expansion Joint.....	113
13. Vertical Expansion Joint at Dissimilar Cladding	114
14. Termination Above Dissimilar Cladding	115
15. Termination at Balcony (Above Slab)	116
16. Termination at Balcony (Below Slab)	117
17. Termination at Grade	118
18. Roof Top Parapet	119
19. Kick-Out Flashing	120
20. Termination at Soffit	121
21. Corner Treatment	122
22. Exhaust Penetration Into Wall	123
23. Scupper Penetration Into Wall	124
24. Signage Attachment	125
25. Rain Water Leader Attachment	126
APPENDIX B: Top 15 EIFS Success Factors.....	127

FOREWORD

Founded in 1987, the EIFS Council of Canada (ECC), a national non-profit industry trade association, represents the overall EIFS industry in Canada. The ECC membership is comprised of EIFS manufacturers, distributors, component suppliers, contractors, building science/design consultants, affiliates and financial services companies. The ECC serves as the “official voice” of the EIFS industry with a mandate to provide for the advancement and growth of the industry across the country, through advocacy, education and marketing. For more information, visit www.eifscouncil.org.

ACKNOWLEDGEMENTS

The EIFS Council of Canada wishes to acknowledge and thank the active members of the ECC Technical Committee for their significant contributions to the development of the EIFS Practice Manual. The Manual has also been subjected to peer review by members of the architectural and design community and the ECC is grateful for any and all input they may have provided in the preparation of the final published version.

Copyright © 2013 EIFS Council of Canada

All rights reserved. No portion of this manual may be reproduced, stored in a retrieval system, or transmitted in any form or by any means, electronic, mechanical, photocopying, recording, scanning, or otherwise, without the prior written permission of the EIFS Council of Canada. Without limiting the generality of the foregoing, no portion of this manual may be translated from English into any other language without the prior written permission of the EIFS Council of Canada.

DISCLAIMER

Exterior Insulation Finish Systems (EIFS) Council of Canada ("ECC")

EIFS PRACTICE MANUAL - *WAIVER and DISCLAIMER*

This EIFS Practice Manual (the "*Manual*"), prepared by, for and at the direction of the ECC Technical Committee, shall serve as a benchmark to all building industry participants interested in using EIFS building solutions that meet or exceed the minimum accepted municipal, provincial and national building code practices and standards (the "*Standards*") for those EIFS building products.

This Manual does not replace professional construction advice and the specific directives of the EIFS manufacturer with respect to the proper professional installation of the chosen EIFS system must be followed in order to fully comply with the Standards. The ECC advises that this Manual is intended to be used only in the specific manner intended to allow full, proper compliance with the Standards. The Manual does not provide any specific guarantees or warranties and commercial suitability is not promised.

While the ECC has taken care to properly and diligently prepare this Manual, the ECC does not warrant or assume any liability for the accuracy or completeness of this Manual or any of its component parts, be it text, drawings, illustrations or otherwise, in any combination whatsoever.

The ECC expressly hereby confirms, and any user of this Manual expressly accepts that it is the responsibility of the user of this Manual to seek, employ and apply the appropriate professional knowledge and experience required for the educated and judicial use of the information contained in this Manual, including any drawings, specifications and/or text and to consult original sources as may be required to inform the decision making process in order to comply with the Standards.

Any user of this Manual expressly waives any rights to bring any action against the ECC or ECC's Technical Committee, its consultants and agents, and agrees that the information provided in the Manual does not represent any professional opinion on any subject referenced in the Manual.

The ECC will not be liable, in any manner, as a result of any user's review of this Manual, for any decisions that are made by that user with respect to design, installation and/or manufacturer selection for any of the EIFS system(s) to be selected for an EIFS project. This Manual is offered to assist the user of this Manual and, where applicable, their professional building advisors, with respect to options available regarding their decisions for design details and specifications for the chosen EIFS system as may be limited by the manufacturer, the installer and the applicable building Standards.

The ECC recommends that any user of this Manual and their professional building advisors be diligent in ensuring compliance with the Standards and following the strict recommendations of the EIFS manufacturer for the EIFS system to be installed in order to meet or exceed the Standards.

Any user of this Manual fully assumes and waives, and ECC specifically disclaims, any liability with respect to the use of this Manual (the "*Waiver and Disclaimer*"). Any user of this Manual hereby accepts, on a fully informed basis and as an express condition precedent of the Manual's use, to be fully and completely bound by this Waiver and Disclaimer.

The Waiver and Disclaimer shall activate immediately upon the user reviewing this Manual, in any manner, in any of its' formats (including e-book format, hard-copy or on-line or its download by the user from the ECC web-site or any companion web sources as approved by ECC).

PREFACE

Exterior Insulation Finish Systems (EIFS) offer many advantages over other types of cladding systems. From an architectural perspective, EIFS offer the ability to replicate almost any architectural style or finish material, coming in a variety of shapes, colours, and textures. EIFS are low cost and lightweight, providing an economical cladding system and the potential for reduced structure costs. EIFS can also be installed over existing buildings, qualifying for points under the LEED Green Building Rating System in Canada (*i.e.*, Materials and Resources [MR] Credit 1, *Building Reuse*).

From a building science perspective, the overall energy performance of a building and its interior environment can be greatly improved by placing the insulation on the outside of the building. This strategy minimizes thermal bridging and helps keep the structural members at a consistent temperature, improving their expected longevity. By keeping the temperature of structural members constant, they are less susceptible to movement and stress caused by temperature swings that could lead to cracking in concrete, masonry and stucco walls. Cracking that in turn can result in water penetration and degradation, such as spalls or corrosion. In addition, with sufficient insulation outboard of the structure, the dew point is moved outside of the structural elements of the wall and the potential for condensation from water vapour diffusion is minimized. Rusting of metal fasteners and metal framing members, deterioration of batt insulation and its R-value, and mould growth, are just a few of the potential effects of condensation that can be avoided. Thermal efficiency is another way in which EIFS can contribute towards LEED-Canada points (*i.e.*, Energy and Atmosphere [EA] Credit 1, *Optimize Energy Performance*), while providing enhanced thermal and moisture protection of the structure.

EIFS has been used successfully in Canada for over 30 years and when properly designed and applied, it has been demonstrated that EIFS can provide excellent performance. Unfortunately, some buildings with EIFS have experienced problems with deterioration and failure that have been widely publicized. As a result, some architects have reservations about specifying EIFS. What many do not realize, however, is that the EIFS itself is extremely watertight. Cladding failures that have occurred are primarily due to poor construction detailing and practices, principally the omission or improper installation of flashing in violation of minimum standards of construction established by Building Codes. Such problems are not unique to EIFS. Similar deterioration and failures have developed at buildings employing other cladding systems. That said, however, the EIFS industry has embarked on a number of initiatives to raise the confidence of the design and construction community in the performance of EIFS.

EIFS Standards

The first of these initiatives was the development and publication of three EIFS Standards in conjunction with the Underwriter's Laboratories of Canada (ULC):

- ULC S716.1, Standard for Exterior Insulation and Finish Systems (EIFS) - Materials and Systems;
- ULC S716.2, Standard for Exterior Insulation and Finish Systems (EIFS) - Installation of EIFS Components and Water Resistive Barrier; and,
- ULC S716.3, Standard for Exterior Insulation and Finish Systems (EIFS) – Design Application.

The first standard, ULC S716.1, outlines requirements for Exterior Insulation and Finish Systems (EIFS) used in combination with a drained air space and water resistive barrier system, as an exterior wall cladding system. It was initially published in 2009. A second edition published in 2011 incorporated the results of a significant research project conducted under the auspices of the Canadian Construction Materials Centre (CCMC), which looked at the drainage capability of EIFS. That comprehensive drainage project is now being used as a model for developing drainage evaluation methods for other wall systems. The second edition of the standard also saw the document significantly reorganized for clarity.

The second standard, ULC S716.2, is an installation standard, first published in 2010. This standard provides requirements for the installation of both EIFS and water-resistive barriers to help ensure the installed performance meets the level of performance established by ULC S716.1. This standard is directed to the installers of EIFS.

The third standard, ULC S716.3, is an EIFS design standard, also first published in 2010. It provides architects with guidance on the proper design of EIFS wall systems that meet the material and system requirements of ULC S716.1 and are installed in accordance with ULC S716.2. However, it is highly recommended that the ULC S716.3 standard be used in conjunction with this manual, as this manual helps to explain the requirements in the design standard and provides details that meet the intent of the design standard.

For the balance of this manual, these three standards will be referred to as the “EIFS Materials Standard”, the “EIFS Installation Standard”, and the “EIFS Design Standard”, respectively.

EIFS Quality Assurance Program (QAP)

The second important initiative of the EIFS Council of Canada was the formation of a not-for-profit corporation, called the EIFS Quality Assurance Program Inc. (EQI). This corporation developed an EIFS Quality Assurance Program (QAP), introduced in Canada in 2011. EQI owns the intellectual property rights and trademarks to the EIFS QAP and is responsible for operating the program.

As part of the EIFS QAP, the EIFS trade contractor receives accreditation based upon compliance with specified administrative procedures and processes and is licensed to use the EQI logo in promotional materials. EIFS mechanics (individual workers) are required to undertake a certification process in accordance with ISO 17024, “Conformity Assessment”, whereby their knowledge of EIFS installations is tested and confirmed against installation standards and manufacturer’s instructions. In addition, the mechanic is required to document the installation process in order to confirm that the project installation requirements have been met. Further, each project will have site audits conducted by EQI in accordance with ISO 17020, “General Criteria for the Operations of Individuals Performing Inspection”. Further information on the EIFS Quality Assurance Program can be found on the EIFS Council of Canada website: www.eifscouncil.org.

EIFS Master Specification

A third important initiative of the EIFS Council of Canada was the publication of an NMS EIFS Master Specification in March, 2010. The EIFS Master Specification acts as the guide specification for the EIFS Quality Assurance Program.

Purpose of This Manual

The EIFS Council of Canada prepared this EIFS Practice Manual to clearly explain the appropriate use of EIFS as an exterior cladding. Specifically, the purpose of the Manual is:

- a) To provide an understanding of Exterior Insulation and Finish Systems (EIFS) in a form that is useful to building designers and specifiers, building code officials, building inspectors, EIFS manufacturers and distributors and contractors;
- b) To provide recommendations for EIFS design and installation practices that promote satisfactory performance and durability;
- c) To complement the ULC S716 series of standards and provide some insight into the technical requirements in the standards; and,
- d) To develop a framework for functional construction details and specifications that generically illustrates acceptable design and construction practices.

Scope of this Manual

This manual focuses specifically on EIFS and its components, the interface between EIFS and other wall elements forming the building envelope, and the hygrothermal performance of EIFS. The manual is divided into four main chapters:

- An Introduction to EIFS;
- EIFS Components;
- Cladding Design Using EIFS; and,
- EIFS Installation.

The manual covers the use of EIFS in new construction, both high-rise and low-rise. Although EIFS installed over concrete and masonry are included, EIFS attached to substrate sheathings that are fastened to either steel- or wood-framed walls dominate in this manual. Most details are common to all substrates.

It is not necessary to read this manual from front to back. For example, designers may wish to jump to the chapter on Cladding Design, and then go back to the chapter on EIFS Components for more specific information on EIFS components.

There are a wide variety of terms specific to the EIFS industry. A glossary of common terms may be found in the Appendix. ASTM E2110, “Standard Terminology for Exterior Insulation and Finish Systems (EIFS)”, provides another reference for EIFS terms.

It is also important to know what is not covered in this manual. In EIFS, thermal insulation supports a base coat that has an integral glass fibre reinforcing mesh. Systems where the reinforcement is the supporting element of the rendering, (e.g., conventional stucco) are not part of this document. The use of EIFS coatings applied directly onto traditional stucco, cement board sheathing, masonry concrete, and Insulated Concrete Forms (ICFs) is not covered. However, some of the principles that are covered could apply to the installation of a full EIFS to an ICF wall, even though such is not explicitly addressed. The design of wind load-bearing backup walls, windows, decks and structures are also not explicitly addressed.

Special interior environments such as ice arenas, swimming pools, high humidity industrial environments, or applications in hot and/or tropical climates are not considered within the scope of this guide. Specialist advice should be sought for these applications.

1. AN INTRODUCTION TO EIFS

1.1 Description

Exterior Insulation and Finish Systems (EIFS, pronounced “eefs”, not “eef-is” or “eef-us”) is described by its name. These cladding systems integrate exterior insulation with a finished appearance that resembles stucco. While some may draw on this comparison and suggest EIFS and stucco are similar cladding systems, EIFS differ from stucco in many respects. However, the primary difference is that in EIFS, the thermal insulation boards support the base coat with integral glass fibre reinforcing mesh. This differs from conventional stucco, where the reinforcement is the supporting element of the rendering.

The fact that EIFS includes the word “System” requires emphasis. One must resist the temptation to consider the “S” as simply the plural of “EIF”. EIFS are proprietary systems that rely upon the constituent components to interact and perform as a composite system. This is unique in comparison to many other cladding materials. Furthermore, since much of the technology involving EIFS is proprietary, if a system is altered (i.e. constituent components are substituted that have not been tested and approved by the manufacturer, performance may be unpredictable and not covered by the manufacturer’s warranty). In fact, the EIFS Installation and Design Standards specifically require that the installed EIFS must consist of the materials and components specified by a single EIFS manufacturer (*ULC S716.2, Clause 4.1*); no alterations to a system or substitution of materials are allowed (*ULC S716.3, Clause 4.1.2*). Before commencing work, the EIFS contractor shall verify that all the materials and components on site are part of the EIFS manufacturer’s system declared as meeting the requirements of CAN/ULC-S716.1 by reference to a parts list or similar documentation provided by the EIFS manufacturer (*ULC S716.2, Clause 4.4*).

Today’s EIFS assemblies typically consist of six (6) components (see Illustration 01-25 in Appendix A):

- A **liquid-applied water resistive barrier** (LA-WRB) over moisture sensitive substrates;
- **Thermal insulation boards**, secured to a structural substrate;
- **Adhesive** and/or **mechanical fasteners**, for attachment of the thermal insulation boards to the substrate;
- A water-resistant synthetic **base coat** applied to the top of the insulation to provide weather resistance and fire protection;
- Glass fibre **reinforcing mesh** embedded in the base coat for impact resistance; and,
- A decorative and protective **finish coat** to provide the colour and texture; the finish coat has the colour right in the mix.

When installed, the base coat, reinforcing mesh and finish coat together are sometimes referred to as the lamina. Joint treatments, drainage accessories, seals, the Liquid Applied - Water Resistive Barrier (LA-WRB) and sealants are components that are to be used with an EIF system and are generally formulated and produced by the EIFS manufacturer.

With the publication of the ULC EIFS standards, the use of a water resistive barrier system (WRB) with EIFS to create a drained cladding assembly over moisture sensitive substrates has become a standard requirement for all EIFS applications. Note again the use of the term,

“system”. A liquid-applied water resistive barrier (LA-WRB) is used with most EIFS (see sidebar). A liquid-applied water resistive barrier is a fluid material applied by spray, roller or trowel that dries to a membrane possessing low water absorption properties. However, such materials cannot span large cracks or interface with different wall elements, such as windows. Therefore, the use of “transition membranes” is necessary. A transition membrane is a reinforced sheet material that maintains continuity of the WRB at joints and openings in the substrate that cannot be bridged with the LA-WRB. Together, the LA-WRB and the transition membranes create the water resistive barrier system – a continuous surface that prevents water penetration into the wall assembly. The water-resistive barrier system may also serve as an air and/or vapour barrier, depending on the design intent of the wall system (see Section 3.5 for more information on air and vapour barriers).

With some EIFS, adhered waterproofing membranes are used instead of a liquid applied water resistive barrier. In these cases, the insulation must be mechanically fastened, as EIFS adhesives do not adhere to polyethylene faced waterproofing membranes. At the present time, the ULC EIFS standards do not cover the use of adhered membranes or mechanical fasteners. However, the standards do not preclude their use. Some guidance on the use of mechanical fasteners is provided in this manual in Section 2.4.9.

CAUTION!

The use of adhered polyethylene faced transition membranes may require the EIFS to be mechanically fastened at these locations. When an adhered waterproofing membrane is used for the transition membrane, it is recommended that a membrane with a fabric-face be used to promote adhesion of the EIFS materials.

In most cases, the EIFS and WRB manufacturer also manufactures the WRB transition materials. In other cases, the EIFS manufacturer may specify the use of another manufacturer’s product.

It is important to note that EIFS do not include components forming the substrate to which the cladding is applied. However, the substrate must be compatible with the EIFS, and be properly designed and installed for the EIFS to perform acceptably.

EIFS can be field applied (i.e., constructed on site) or assembled as panels off-site in a factory. Panelized EIFS are brought to the site, anchored to the building, and the joints between the panels sealed, similar to precast concrete. Once completed, field-applied and panelized EIFS look similar, although panelized EIFS will typically have wider expansion joints than field-applied EIFS. Panelized EIFS will also have more joints than field-applied EIFS.

In addition to the ability to provide various forms and finishes, a designer must consider the performance capabilities offered by EIFS, and select systems from manufacturers that incorporate features that meet the project requirements. Considerations include: fire safety, thermal resistance, resistance to rain penetration, interior air and moisture control, impact resistance, and other aspects of durability. Such considerations are covered in Chapter 3, Cladding Design Using EIFS.

1.2 History

EIFS originally evolved in Europe when conventional stucco was applied over insulation due to the benefits of increased thermal performance. The original use of stucco in Europe and elsewhere was to cover brick as a waterproof coating.

The advent of polymer chemistry in post-war Europe led to the development of foamed plastic insulation and modern coatings that formed “laminae” in lieu of the traditional stucco. EIFS were first used in North America in the late 1960s and have now developed a significant share of the cladding market with billions of square feet having been successfully installed.

Formerly, EIFS were classified as being either Polymer Based (PB) (also referred to as “soft coat, thin, or flexible”), or Polymer Modified (PM) (also referred to as “hard coat, thick, or rigid coat”). PB systems tended to be thin, and flexible as a result of the higher polymer content in the base coat. While the majority of PB base coats contained cement, some did not. PM systems tended to be thicker, harder, and more rigid as a result of less polymer and a higher cement content. PM systems also tended to require mechanical fastening and more control joints to accommodate movements without cracking.

There is now a range of lamina thicknesses and cement/polymer ratios employed by manufacturers. Attempting to classify EIFS according to lamina thickness or by the degree of polymerization is no longer practical nor useful. As a result, these classifications have become obsolete, and are no longer used in Canada. The classifications that are of greater interest are the ability for the EIFS to comply with Building Code requirements pertaining to fire safety, control of rain penetration, and impact resistance.

2. EIFS COMPONENTS

As noted in the previous chapter, today's EIFS assemblies typically consist of six (6) components: A liquid-applied water resistive barrier (LA-WRB), adhesive, thermal insulation board, base coat, reinforcing mesh and finish coat. With the publication of the ULC EIFS standards, the use of a water resistive barrier system (WRB) with EIFS to create a drained cladding assembly over moisture sensitive substrates has become a standard requirement for all EIFS applications. Mass walls are specifically discussed in Section 2.1.1; otherwise, throughout this Manual, it is assumed that a WRB is being used with the EIFS.

The substrate, to which the WRB is applied, while not part of the EIFS, is also critical to the performance of the EIFS. Typically, the WRB is applied to the substrate and the EIFS insulation is adhered to the WRB. If there are problems with the substrate that affect the bond of the WRB, the entire EIFS is affected. Therefore, this Chapter starts with a detailed look at the substrate and how it can affect the performance of the EIFS, followed by a discussion on the WRB system, and the individual EIFS components (in order of application): insulation, insulation adhesive and fasteners, base coat, reinforcing mesh, and finish coat. For each component, information is provided on the technical requirements for the component, and how the component affects the overall performance of the EIFS cladding. Throughout, reference is made to the ULC EIFS standards to provide context for the requirements in the standards. The latter parts of this chapter deal with the lamina as a composite of the base coat, reinforcing mesh and finish coat, and with the use of mouldings and trims used to create architectural profiles.

Throughout this manual, reference is made to the "Manufacturer's Published Written Installation Instructions", which are defined in all EIFS Standards as, "Manufacturer's Installation Instructions - written installation instructions provided by the EIFS manufacturer that include information that will assist in the correct use and installation of the materials and components that comprise their system". In some cases, the EIFS Standards allow the Manufacturer's Published Written Installation Instructions to override the limits provided in the Standards, such as using a product outside of the normal temperature limits provided in the EIFS Installation Standard. By allowing such uses, the manufacturer is acknowledging responsibility for the performance of their product outside of the limits otherwise established by the EIFS Standards for use of EIFS products.

CAUTION!

2.1 Substrate

2.1.1 Not Part of the EIFS

In addition to functions such as resisting live loads and supporting windows, the substrate is a structural component of the building supporting the water resistive barrier system and the EIFS. It is not part of an EIFS cladding. In fact, both the EIFS Design and Installation Standards specifically state that the standard does not apply to the substrate, except insofar as the substrate impacts the performance of the EIFS (*ULC S716.2, Clause 1.2; ULC S716.2, Clause 1.5; ULC S716.3, Clause 1.3*). However, the substrate must be compatible with the EIFS and the WRB, and must be properly designed and installed for the EIFS to perform acceptably.

2.1.2 Structural Adequacy

While the EIFS Standards do not address the structural design of the substrate, nonetheless, the substrate must be structurally designed to possess adequate strength and rigidity to support the EIFS cladding and lateral loads (typically wind), as required by the applicable Building Code (*ULC S716.3, Clause 11.1.2*). The substrate must also be designed to support any other structural loads that are an inherent part of the building design and must be adequately reinforced around openings, such as windows and doors. Unique details, such as parapets and balustrades, must be taken into account. Further, the structure and cladding must be designed with joints wide enough to accommodate movements that arise from structural deflections, thermal cycling, and shrinkage or creep (see Section 3.3. for more information on design of EIFS for movement). The EIFS installer or manufacturer is not to be expected to take responsibility for the structural design or integrity of the substrate to which the EIFS is attached.

Where applicable, prescriptive Building Code requirements (such as National Building Code of Canada (NBC) Part 9 requirements for wood framed walls) can be relied upon to help design a suitable back-up substrate to receive the EIFS. In other cases, structural engineering design can be used to establish substrate details appropriate for a specific project. However, such design is typically not included within the mandate of a building structural designer, so attention is required to assure that design responsibility for the EIFS substrate is assigned. A specialist professional could be retained to establish the structural design to be incorporated within the design documents. Alternatively, the responsibility for design and submission of shop drawings can be assigned to the builder, who in turn would need to retain the services of a specialist professional.

Where EIFS is to be applied to an existing building, it is especially important that the structural adequacy of the building is determined and appropriate reinforcement and/or remedial measures necessary to provide acceptable structural integrity are designed and implemented prior to installing the EIFS (*ULC S716.3, Clause 11.1.3*). Determination of the structural adequacy of the building depends on many factors, including knowledge of the applicable loads that will be applied; such design is within the purview of professional engineering and is beyond the scope of this manual.

2.1.3 Substrate Condition

The condition of the substrate surface is also very important to the installation of the LA-WRB and EIFS. The substrate surface must be:

- Firm, structurally sound and undamaged;
- Dry;
- Not less than 4°C (40°F); and,
- Sufficiently flat.

Structural Soundness

The substrate surface must be firm, structurally sound and undamaged to ensure an adequate bond is maintained with the LA-WRB. The EIFS and LA-WRB must not be installed on broken, cracked, rotted, decayed or delaminated substrate sheathing boards, nor on loose, spalling or crumbling concrete or masonry (*ULC S716.2, Clause 6.2*). Any such conditions could result in an inadequate bond.

Contaminant Free

The substrate must be free of any surface contaminants that could affect the adhesion of the adhesive and/or the LA-WRB, such as oil or grease, dust, direct form-release agents, curing compounds, paint, wax, glazing, water, moisture, efflorescence or laitance, frost, etc. (*ULC S716.2, Clause 6.4 to 6.8*). The EIFS contractor shall visually confirm that the substrate is acceptable prior to starting and throughout installation of the EIFS or the LA-WRB. Installation of the EIFS or the LA-WRB shall not proceed if the substrate is deemed unacceptable by the EIFS contractor (*ULC S716.2, Clause 6.12*). As indicated previously, the EIFS installer is not to be expected to take responsibility for the structural design or integrity of the substrate to which the EIFS is attached however; the installer is to check for surface contaminants. The installer shall communicate with the general contractor regarding possible surface contaminants that may not be visible on the substrate surface, such as form-release agents.

Loose dirt and dust is to be removed from the substrate before the EIFS is installed. The cleaning methods used will depend on the substrate type and surface condition, but could include brushing, water spray, etc. (*ULC S716.2, Clause 6.5*).

The EIFS Installation Standard does allow the LA-WRB to be installed on damaged surfaces that have been repaired; however, the EIFS Installation Standard does not specify how damaged surfaces must be repaired, as such repairs are not considered to be the EIFS installer's responsibility (unless the EIFS installer constructed the substrate); it is the responsibility of the general contractor to ensure that any repaired surfaces are structurally adequate and sound to receive the EIFS. The general contractor should contact the design professional as required for input.

It may be advisable to use supplemental mechanical fasteners to ensure that the EIFS is adequately secured to existing surfaces, such as old masonry (*ULC S716.2, Clause 6.2, Note*).

For retrofit applications, supplemental fasteners are required over previously painted/coated concrete and masonry surfaces if the coatings are not removed. Cementitious adhesive and coatings may break down over certain coatings/paint.

Dry

Most water resistive barriers will not adhere to wet surfaces, although some EIFS manufacturers have developed specialized products for this purpose. While the EIFS Installation Standard requires that EIFS and the LA-WRB only be installed on dry substrates with no visible moisture such as condensation, dew or frost, the Standard does allow such installation where permitted by the Manufacturer's published written installation instructions (*ULC S716.2, Clause 6.8*).

Where a manufacturer is providing a specialized product that can be used on a wet surface, the allowable usage of the product must be clearly stated in the Manufacturer's published written installation instructions. In such circumstances, while not part of the standard battery of tests required by the EIFS Materials Standard, the manufacturer should have tested their product for the conditions under which it will be used, as by putting such information in their installation instructions, the manufacturer is acknowledging responsibility for the performance of their product outside of the limits otherwise established by the EIFS Standards. It is recommended that the responsible design professional review the test report that establishes the ability of the product to perform in such situations.

Temperature

Another requirement for installation of EIFS or the LA-WRB is that the substrate must not be below 4°C (40°F) at the time of application, or during drying and curing of the LA-WRB. At temperatures below 4°C, there is a risk that an invisible film of frost may form on the surface of the substrate that will affect the bond of the WRB system in addition to reducing the material temperature more quickly when applied. There is also the risk that the drying or curing of the products may be prolonged or halted due to the cold temperature. Some EIFS manufacturers have developed specialized products for installation at lower temperatures and the use of such products is allowed by the EIFS Installation Standard (*ULC S716.2, Clause 6.11*). Again, where a specialized product for use at low temperatures is being provided, such information must be clearly stated in the Manufacturer's Published Written Installation Instructions. It is recommended that the design professional review the test report in consultation with the manufacturer to establish the ability of the product to perform in such situations.

Flatness

The substrate to which an EIFS is applied must be sufficiently flat. As will be seen in Section 2.4.6, after the thermal insulation board is applied to the substrate, the thermal insulation board is rasped to ensure that its surface is flat to within ± 3 mm ($1/8$ in.) in 1220 mm (4 ft) in any direction across flat wall areas, primarily for aesthetic reasons. Surface irregularities in the substrate will reflect through to the surface of the insulation and rasping of the insulation to achieve the desired surface could result in a significant reduction of the insulation thickness. A substrate that is not flat will also compromise the bond of the insulation by affecting the continuity of contact between the adhesive and the substrate. Gaps may also be created between the thermal insulation boards. As a minimum, the EIFS Installation Standard requires substrates to be straight and flat in all directions with no variations in excess of 6 mm ($1/4$ in.) over a 2400 mm (8 ft.) length (*ULC S716.2, Clause 6.10*). Some manufacturers may have more stringent requirements for their systems, which would supersede the requirements in the EIFS Installation Standard.

Compatibility Issues

Some manufacturers have different systems or materials depending on the substrate. As a minimum, the substrate must be compatible (i.e. cementitious adhesives in direct contact with wood substrates is not recommended) with the EIFS and LA-WRB and must meet the criteria set by the manufacturer (*ULC S716.3, Clause 11.1.4*). There are two main types of substrate to which EIFS may be applied:

- Masonry or Mass Concrete; and
- Sheathing Boards over Framing.

These substrates are covered in the sections below.

2.1.4 Mass Wall as an EIFS Substrate

Properly constructed masonry or mass concrete is well suited as a substrate for the water resistive barrier system and/or for the EIFS directly. These types of walls are typically referred to as “mass walls”, as a great deal of their rainwater penetration resistance is due to their mass. When a wall is comprised of masonry or concrete, the EIFS may be applied directly to the masonry or concrete without the use of a substrate sheathing or the use of a WRB, since these types of walls are more moisture tolerant than some other types of substrates. This has been a standard practice in Europe and elsewhere for more than 50 years.

Typically, to be suitable for direct application of EIFS, the mass wall must meet all building code requirements in and of itself if exposed to the elements. Examples of such mass walls include multi-wythe masonry, cast-in-place or precast concrete, and a masonry veneer rainscreen¹. Even though masonry and concrete are often directly exposed to rain, some entities (e.g., a municipality) may still require the use of a WRB behind the EIFS. For example, the use of a WRB behind EIFS is recommended if the EIFS is applied to a unit masonry (single wythe) wall.

It is important that newly placed cast-in-place concrete or masonry is allowed to cure before the LA-WRB or EIFS is applied to ensure that the migration of moisture out of the wall does not affect the bond. The same is applicable for concrete or masonry repairs. The typical cure time for concrete or masonry to reach their design strength is 28 days. However, some cementitious materials are designed to provide rapid curing, in which case the cure time may be less. The EIFS Installation Standard requires a minimum 28-day curing time unless the repair material is specifically designed to provide rapid curing (*ULC S716.2, Clause 6.3*).

The condition of the substrate must be checked before installing the LA-WRB or EIFS. Form-release agents on concrete walls, masonry treated with penetrating water repellents, and old paint on concrete block, may not allow for an acceptable bond. Efflorescence, laitance, old paint and any loose particles must be removed prior to application of the EIFS or LA-WRB. If the surface is rinsed with clean potable water, it should be allowed to dry before the EIFS or LA-WRB installation commences (*ULC S716.2, Clause 6.6*). If there is any doubt about the quality of the substrate, field testing should be conducted with the system specified for the project.

¹ A masonry veneer rainscreen is not a mass wall however for the purposes of this manual; it can be treated in a similar context as a mass wall since the rainscreen has built in redundancy.

Special care must be taken in retrofit applications, where the existing concrete or unit masonry is deteriorated, which can affect proper EIFS attachment. Local substrate repairs may be required prior to attachment. The use of supplemental mechanical fastening may also be necessary. The responsible design professional should evaluate the substrate and provide repair recommendations.

It is often not necessary to provide drainage when EIFS is applied directly over a suitable mass wall, as described above. However, source drainage at window sills (see Illustrations 04-25 to 06-25 in Appendix A) and joints is still required. If a WRB is to be used, it should be noted that a liquid applied water resistive barrier has only a limited ability to span cracks. As a result, the EIFS Installation Standard requires that any concrete or masonry cracks wider than 1 mm must be repaired prior to application of the LA-WRB (*ULC S716.2 Clause 6.9*).

2.1.5 Framing and Sheathing Boards as an EIFS Substrate

EIFS can be applied to a framed wall constructed of wood or hot- or cold-formed steel, clad with a variety of sheathing products, including exterior non-paper faced gypsum-based sheathing boards, cement-based sheathing boards, and wood-based sheathing boards.

Framing

In comparison to rigid cladding systems, such as masonry, cast-in-place concrete, or precast concrete, EIFS has greater ability to accommodate substrate flexure or other movements without cracking. However, cracking can occur if the framing to which the EIFS is applied exceeds permissible deflection limits. The rigidity/stiffness of the substrate required to minimize the risk of EIFS cracking varies according to specific products. Manufacturers typically specify maximum permissible deflections for their products as a ratio of the length of span between cladding supports (L). $L/240$ is the maximum allowable deflection for EIFS unless stipulated otherwise by the manufacturer.

Buildings constructed of wood framing that are designed and constructed to meet Part 9 of the Building Code will be sufficiently rigid for most EIFS applications. Steel studs are generally more flexible than wood studs, so more attention must be given to flexibility considerations when steel studs are used. Where steel studs are used in house construction as load-bearing walls, the wall must be designed to Part 4 of the Building Code. This means that an engineer must be involved in the design.

For substrate systems constructed with a cold-formed galvanized steel stud frame, minimum 18-gauge studs should be employed. This is consistent with best practice recommendations provided by the steel stud manufacturing and brick cladding industries. This minimum thickness improves confidence that strength and stiffness requirements will be achieved, results in a framing system which can be more effectively and reliably connected by either screw fastening or welding, and provides more robust members that can better tolerate problems with localized corrosion damage without significant structural weakening.

To provide adequate resistance to corrosion in the presence of accidental or periodic exposure to moisture, all steel framing forming part of the exterior cladding back-up should be hot dipped galvanized in conformance with CAN/CSA G164 – “Hot Dip Galvanizing of Irregularly Shaped Articles”. If welded connections are employed, welds must be protected by a zinc rich coating.

For pre-fabricated or engineered stud wall assemblies, shop drawings should be prepared to design and detail the back-up structure. These drawings should be sealed by a Professional Engineer, and must indicate the design wind loads and deflection limits. This requirement is suggested to assure the back-up substrate has been designed to meet the structural strength and rigidity requirements required by the Building Code and the selected EIFS manufacturer. The drawings should include:

- Details for securement of the steel studs to the structure;
- Deflection details (if required), including the maximum movement to be accommodated;
- Reinforcing at windows and doors;
- Unique details, including parapets and balustrades;
- Sheathing type; and,
- Sheathing fastening requirements (fastener type, spacing and pattern).
- A design professional should check the shop drawings as part of the design review.

Sheathing Boards

A variety of products are suitable as sheathing under EIFS. In general, sheathing materials must be:

- Tolerant to incidental moisture; and
- Able to withstand wind loads.

The substrate can often be exposed to rain wetting during construction (depending on building envelope sequencing). Wetting of the substrate may also occur at localized areas during service as a result of rainwater penetration through defects that are not promptly addressed by maintenance or repair. The use of a water resistive barrier eliminates most of the problems experienced in the past related to water damage of the substrate. However, interior sources of wetting can also lead to wetting of exterior wall components. These can include air or vapour barrier defects (see Section 3.5 for more information on air and vapour control), plumbing leaks or air conditioning condensate leakage. While many of these risks for moisture contacting the EIFS substrate are not related to the EIFS performance, substrate and EIFS replacement may become necessary if the substrate cannot tolerate these loads and deteriorates. Therefore, it is still important that the substrate be tolerant to incidental moisture.

Exterior grade gypsum board sheathing (commonly referred to as paper-faced gypsum), compliant with ASTM C79, “Standard Specification for Treated Core and Nontreated Core Gypsum Sheathing Board”, has been used in the past as substrate sheathing. However, it has been found to be too moisture sensitive; it is vulnerable to deterioration from wetting prior to being covered with EIFS and from accidental periodic wetting that may occur over the service life. Such paper-faced gypsum board sheathing can readily lose structural integrity and mould can grow on paper facings, presenting a health risk to building occupants. Therefore, exterior grade, paper-faced gypsum board sheathing must not be used as a substrate.

Substrate sheathings that are tolerant to incidental moisture, if not exposed to prolonged wetting include oriented strand board (OSB), plywood, and glass-fibre-faced core-treated gypsum, meeting ASTM C1177, “Standard Specification for Glass Mat Gypsum Substrate for Use as Sheathing”. Sheathing compliant with ASTM C1278, “Standard Specification for Fiber-Reinforced Gypsum Panel”, may also be used.

Wood based sheathings tend to better resist isolated, periodic wetting events than sustained wetting. Plywood sheathing has been found to provide improved durability as compared with oriented strand board (OSB) sheathing. However, both are vulnerable to deterioration and mould growth if exposed to sustained wetting arising from unrepaired defect(s).

In applications where the EIFS is secured to sheathing, the sheathing must be able to withstand wind loads, which requires proper fastener selection, spacing and framing support at board edges. ASTM C 1280-09, “Standard Specification for Application of Gypsum Sheathing”, can be used as a guideline for the proper installation of sheathing. In addition to the requirements in that standard, the joints in the sheathing should not line up at window corners (see Figure 2) as cracks may telegraph through the insulation and cause the lamina to crack.

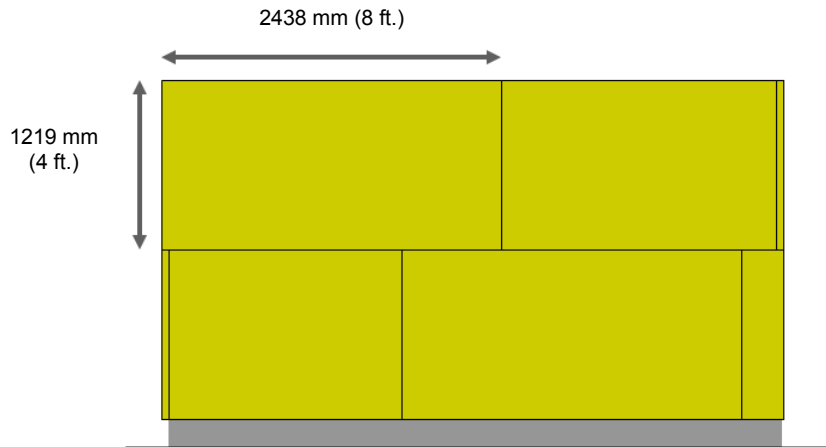

Figure 1: Sheathing board orientation to be lengthwise, perpendicular to the studs, offset vertical joints by at least one stud.

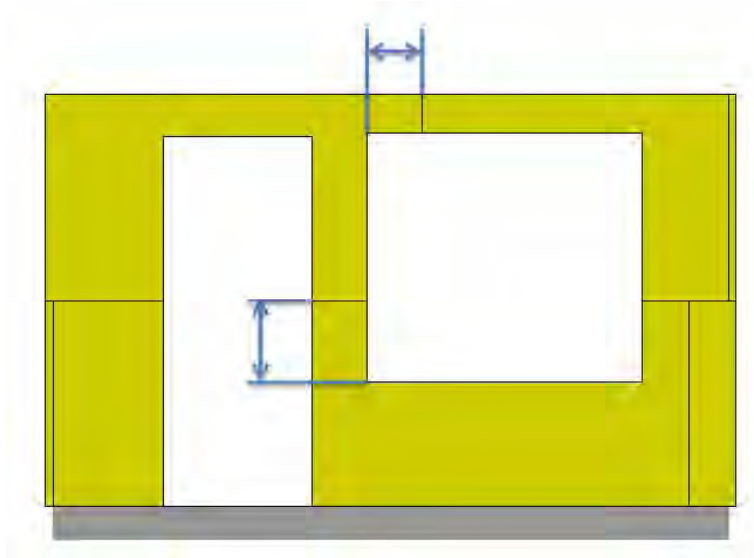

Figure 2: Sheathing board joints to be staggered and not aligned with corners of openings, offset vertical joints by at least one stud.

All sheathing fasteners must be corrosion resistant to assure long-term durability as required by Code.

The back-up wall requires joints wide enough to accommodate movements that arise from structural deflection, thermal movements, shrinkage or creep. This topic is dealt with in more detail in Section 3.3.

2.2 Water Resistive Barrier

With the publication of the ULC EIFS standards, the use of a water resistive barrier system (WRB) with EIFS to create a drained cladding assembly over moisture sensitive substrates has become a standard requirement for all EIFS applications. The water resistive barrier system consists of a liquid-applied water resistive barrier (LA-WRB), and transition materials to span cracks or interfaces with different wall elements, such as windows. Unless the substrate is inherently resistant to water, such as a mass concrete or masonry wall, a WRB must be installed. Be aware that even though concrete or masonry walls are often directly exposed to the elements when not overclad with EIFS, some entities (e.g., a municipality) will still require the use of a WRB on concrete or masonry under an EIFS.

The WRB is intended only as the secondary line of defence against water penetration; the EIFS base coat is the first line of defence. However, should any water inadvertently reach the WRB, a means must be provided to drain such water and direct it back to the exterior of the wall. The water resistive barrier system may also serve as an air and/or vapour barrier depending on the design intent of the wall system (see Section 3.5, Air and Vapour Control for more information).

2.2.1 Material

A liquid-applied water resistive barrier is a fluid material, applied by spray, roller or trowel, which dries to a membrane possessing low water absorption properties. The LA-WRB is installed on the substrate, and in effect, becomes the substrate for the installation of the EIFS. The important properties of the LA-WRB include:

1. The ability to bond to the substrate;
2. The ability of the EIFS adhesive to bond to LA-WRB;
3. Resistance to water penetration;
4. Water vapour permeance; and,
5. Resistance to UV radiation.

When the LA-WRB is applied to a sheathing substrate, additional important properties of the LA-WRB include its:

6. Resistance to nail pops in wood sheathing; and,
7. Durability across joints in the substrate sheathing.

In some EIFS, adhered waterproofing membranes are used instead of a liquid applied water resistive barrier. In these cases, the insulation must be mechanically fastened, as EIFS adhesives do not adhere to polyethylene faced waterproofing membranes. At the present time, the ULC EIFS standards do not cover the use of adhered membranes or mechanical fasteners. However, the standards do not preclude their use. Some guidance on the use of mechanical fasteners is provided in this manual in Section 2.4.9.

The use of adhered polyethylene faced transition membranes may require the EIFS to be mechanically fastened at these locations. When an adhered waterproofing membrane is used for the transition membrane, it is recommended that a membrane with a fabric-face be used to promote adhesion of the EIFS materials.

2.2.2 Ability to Bond to the Substrate

The ability of the LA-WRB to bond to the substrate is evaluated as part of the testing requirements of the EIFS Materials Standard (*ULC S716.1, Clause 5.4.3*). A number of small test specimens are made consisting of the LA-WRB applied to a variety of substrates. The bond test (described in Annex A of the EIFS Materials Standard) involves the use of a test apparatus that is adhered to both sides of a test specimen. The testing apparatus applies a tensile (or pulling) load to the specimen at a pre-determined rate of speed, until the specimen ruptures. The bond strength is then calculated as the breaking load divided by the minimum cross-sectional area of the test specimen (kN/m^2).

Not all LA-WRB materials are suitable for all substrates. Therefore, most EIFS manufacturers will have more than one LA-WRB that can be used with their EIFS. The manufacturer will specify which of their products is suitable for which substrates. It is important that the appropriate LA-WRB is specified for the planned substrate material.

Where the LA-WRB is to be applied to the surface of an existing building, field adhesion testing is recommended to verify that an acceptable bond can be achieved by products applied to the aged substrate (*Refer to ASTM E2134 Standard Test Method for Evaluating the Tensile-Adhesion Performance of an Exterior Insulation and Finish System (EIFS)*).

2.2.3 Ability to Bond to the Adhesive

The ability of the EIFS adhesive to adhere to LA-WRB is evaluated in the same way as the bond of the LA-WRB to the substrate.

In some manufacturers' systems, the LA-WRB is also used as the adhesive for the thermal insulation board. If this is the case, the bond of the LA-WRB to the thermal insulation board must be tested. This type of application requires two coats of LA-WRB, the first to provide the water resistive coating and the second to adhere the insulation.

2.2.4 Resistance to Water Penetration

While the WRB is only intended to be a secondary line of defense against water penetration, it is still important that it be resistant to water penetration. Therefore, the EIFS Material Standard requires the water absorption coefficient of the LA-WRB to be determined (as described in Annex B of the EIFS Materials Standard). The water penetration resistance of the LA-WRB is assessed by submerging the coated surface of OSB under 100 mm of water and measuring the changes in mass over time, for a period of at least 72 h. To pass the test, the water absorption coefficient must not exceed $0.004 \text{ kg}/(\text{m}^2 \cdot \text{s}^{1/2})$ (*ULC S716.1, Clause 5.4.4.1 and Clause 5.4.4.2*).

2.2.5 Resistance to Vapour Penetration

The EIFS Materials Standard requires the water vapour permeance of the LA-WRB to be evaluated in accordance with ASTM E96, "Standard Test Methods for Water Vapor Transmission of Materials", using the water method (*ULC S716.1, Clause 5.4.5.2 and 5.4.5.3*). Four test specimens made by applying the LA-WRB to glass mat gypsum sheathing (which is relatively vapour permeable and will have little effect on the test results) are tested. The LA-WRB is exposed to the vapour pressure created by a sealed container of distilled water. The water vapour permeance of the LA-WRB is reported as the average of the four results in $\text{ng}/(\text{Pa} \cdot \text{s} \cdot \text{m}^2)$ (*ULC*

S716.1, Clause 5.4.5.4). There is no pass/fail criteria for this test in the EIFS Materials Standard; however, when it comes to the design of the wall system for air and vapour control, it may be necessary for the designer to know the vapour permeance of the LA-WRB.

2.2.6 Resistance to UV Radiation.

While the LA-WRB will not be subjected to long term UV radiation exposure as it will be covered by the EIFS, it must have some UV resistance as, depending on the construction sequencing on a building, there may be a certain length of time that it is exposed before the EIFS is installed. Therefore, the EIFS Materials Standard requires that the LA-WRB is subjected to an accelerated weathering test involving cycles of both simulated UV radiation and water spray for a total period of 336 hours (*ULC S716.1, Clause 5.4.6*). The test is conducted in accordance with ASTM G154, “Standard Practice for Operating Fluorescent Light Apparatus for UV Exposure of Nonmetallic Materials” and involves three specimens of LA-WRB applied to oriented strand board. Each specimen measures 100 mm x 150 mm (4 in. x 6 in.). At the end of the test, none of the three specimens tested can exhibit any visible deleterious effects, such as cracking, delamination or flaking. The weathering test for the LA-WRB is not as severe as the weathering test of the lamina, as the expected long-term exposure of the two is very different.

2.2.7 Nail Pop Resistance

Where the LA-WRB is intended for installation on a wood-sheathed wall, the possibility exists that deflections and movements of the framing may cause nail popping. To ensure that the LA-WRB can resist nail popping, any LA-WRB intended for use on a wood-sheathed wall is also tested for nail pop resistance (*ULC S716.1, Clause 5.4.8*). In this test (described in Annex D of the EIFS Materials Standard), the LA-WRB is installed on a wood specimen that has a nail embedded 1.0 mm ($1/32$ in.) below the surface. After the LA-WRB has cured, the nail is pushed back upwards through the wood a distance of 1.0 mm ($1/32$ in.). There must be no visible cracking or delamination of the LA-WRB around the nail for the LA-WRB to pass the test; a simple bulge in the LA-WRB at the nail head does not constitute a failure of this test.

2.2.8 Joint Durability

The building structure, and therefore the LA-WRB can be expected to go through thermal expansion and contraction with changes in temperature over the course of the year. The weakest spot of the LA-WRB is at the joints in the substrate. Therefore the EIFS Materials Standard requires that a test be conducted over wood sheathing to evaluate the ability of the LA-WRB to span cracks and maintain its integrity when subject to temperature extremes (*ULC S716.1, Clause 5.4.7*).

To conduct the test (described in Annex C of the EIFS Materials Standard), the LA-WRB is applied to OSB sheathing that has a 3.2 mm ($1/8$ in.) gap between sheathing boards. The specimens are installed in a test frame and then stretched 1.3 mm ($2/32$ in.) to widen the sheathing gap. The specimens are then subjected to temperature extremes of 65°C (150°F) for 18 hours and -10 °C (14°F) for five hours (with an hour at room temperature between extremes to prevent thermal shock) for a total period of 360 hours. Specimens that have survived the test with no apparent damage are then subjected to a water penetration test to determine if there has been any failure in the LA-WRB. Any passage of water is deemed a failure of the test.

2.2.9 Application

Before the LA-WRB is applied, any joints in the substrate sheathing boards must be treated according to the Manufacturer's published written installation instructions (*ULC S716.2, Clause 8.1.1*). Typically, manufacturers will require the joints to be treated with a reinforcing mesh of some kind, either a self-adhesive mesh or a textile and fibreglass blend reinforcing mesh. The LA-WRB must then be applied over the entire substrate at the thickness specified in the Manufacturer's published written installation instructions (*ULC S716.2, Clause 8.1.4*). In some cases, the manufacturer may require that more than one coat of the LA-WRB be applied. The first coat of any LA-WRB application must be allowed to dry before additional coats are applied including those used to secure the insulation board.

The environmental conditions at the time the LA-WRB is applied and the temperature of the surface to which it is being applied are important considerations. The EIFS Installation Standard requires that the LA-WRB must not be applied:

1. When the ambient temperature is less than 4 °C (40 °F) (*ULC S716.2, Clause 8.1.2*);
2. When the substrate surface temperature is less than 4 °C (40 °F) (*ULC S716.2, Clause 6.11*);
3. When the substrate surface temperature is more than 40 °C (104 °F) (*ULC S716.2, Clause 8.1.2*); or,
4. When the LA-WRB temperature is more than 40 °C (104 °F) (*ULC S716.2, Clause 8.1.2*).

Of course, the Manufacturer's published written installation instructions may allow application of the LA-WRB at conditions other than those stated above. If such is the case, the Manufacturer's published written installation instructions must be followed.

2.2.10 Transition Membranes and Materials

A transition membrane is defined as a component of the water resistive barrier system that maintains continuity of the WRB at joints and openings in the substrate that cannot be bridged with the LA-WRB.

The continuity of the LA-WRB must be maintained at terminations where the EIFS interfaces with other cladding systems and/or cladding components so as to prevent moisture penetration inwards of the plane of the LA-WRB (*ULC S716.3, Clause 12.1.5*). To ensure that the secondary line of moisture protection is complete, the WRB must be made continuous at: openings, penetrations and joints in the substrate, expansion joints, flashing, junctures to fenestration or other walls systems, and junctures with roofing membranes (*ULC S716.2, Clause 8.1.5*). Since the LA-WRB has a limited ability to span cracks and expansion joints, there is a need for sheet transition membranes (e.g. fabric-faced waterproofing membrane products) and/or flashing materials (e.g., liquid applied coatings with reinforcement mesh) that maintain continuity of the WRB system. The manufacturer provides installation details to be used in conjunction with the LA-WRB over joints at floor levels, over ridge flashings, and substrate expansion joints. The selection of the product is dependent on the expected movement and joint size.

The sheet transition membrane or flashing material must be of sufficient width to lap both sides of a joint, gap or transition by a minimum of 50 mm (2 in.). The maximum width of the lap shall be as specified by the Manufacturer's Written Installation Instructions. Where the transition membrane bridges a joint or opening, such as an expansion joint in the substrate, it must be supported by a backer rod or similar material (*ULC S716.2, Clause 8.2.3*). Where a transition membrane is used at a building expansion joint, the membrane must be detailed (i.e. looped into joint) to allow for the expected movement.

In some cases, primer must be applied to the substrate before the application of the transition membrane. The need for a primer will depend on the substrate and the product being applied. The Manufacturer's published written installation instructions should be followed with respect to the need for a primer and its application. Typically, the primer should be allowed to become tacky before the transition membrane is installed, but should not be left exposed longer than allowed by the manufacturer nor longer than one day; otherwise, the primer will need to be reapplied (*ULC S716.2, Clause 8.2.4*). After the transition membrane is placed on the wall, it must be immediately rolled to ensure continuous adhesion. The type and size of roller used should be as recommended by the Manufacturer's published written installation instructions (*ULC S716.2, Clause 8.2.5*).

2.2.11 Drainage and Flashing

EIFS cladding is designed to minimize the ingress of precipitation into the assembly by the first plane of protection (the lamina) and flashings/overhangs which deflect water away from the wall surface. However, should incidental moisture penetrate past the first plane of protection, the continuous second plane of protection (the water penetration barrier system and drainage cavity) prevents ingress into the interior space and effectively dissipates by drying or to the exterior via flashings.

The drainage cavity incorporates an air space and can be created in one of three ways:

1. Adhesive ribbons (see Figure 3); or,
2. Geometrically defined thermal insulation board (see Figure 4); or,
3. A combination of 1 and 2 (see Figure 5).

Adhesive ribbons are vertical lines of adhesive used to secure the thermal insulation board to the wall substrate (either the WRB, or masonry or concrete in the case of a mass wall). The ribbons are created by applying the adhesive with a notched trowel. The thickness of the adhesive, which is dictated by the trowel used, creates a gap between the back of the thermal insulation board and the substrate, which allows for the drainage of water. The adhesive is discussed in more detail in the next section.

Geometrically defined thermal insulation board has grooves or other shapes cut out of the insulation to provide channels for the drainage of water; the drainage space thus created is referred to as a geometrically defined drainage cavity (GDDC).

The method in which the drainage cavity is created is generally part of the proprietary nature of the EIFS. Regardless of how the cavity is create, it must be continuous between flashings, terminations, etc.

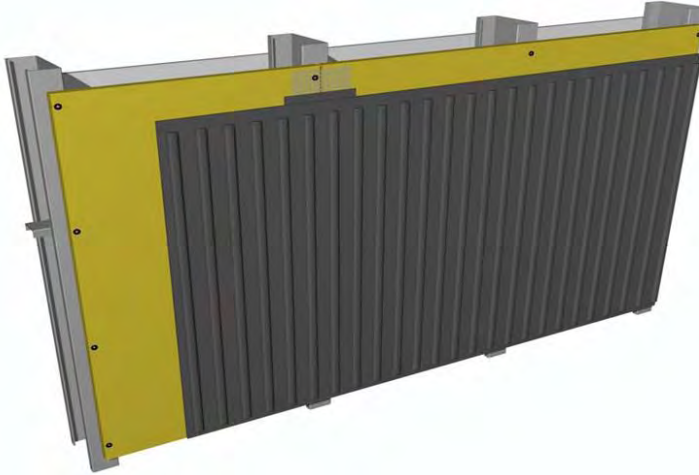

Figure 3: Adhesive applied to substrate by notched trowel.

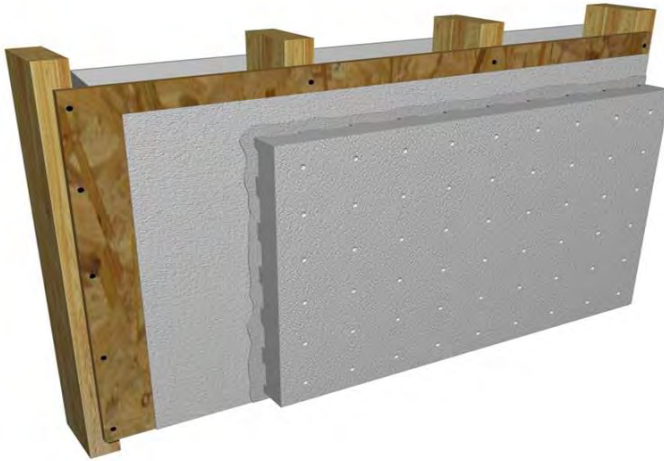

Figure 4: Geometrically defined drainage cavity insulation placed over wet adhesive applied to substrate covered with WRB. (Note: Method of adhesive attachment is proprietary).

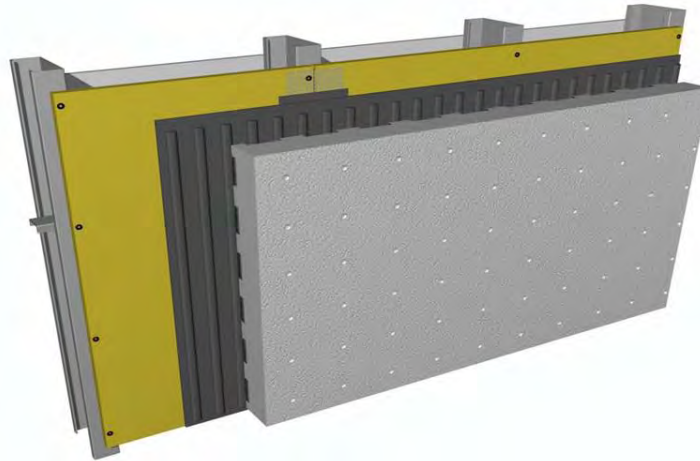

Figure 5: Geometrically defined drainage cavity insulation placed over wet adhesive applied to substrate with a notched trowel (vertical ribbon pattern).

Based on the model building code, some provinces with high moisture load regions (e.g., coastal areas) have adopted the requirement that the two planes of protection are to be separated by a 10mm capillary break to permit drainage and venting for Part 9 buildings. The EIFS Materials Standard now includes a test of the drainage capacity of an EIFS based on extensive research programs. The research demonstrated that a 10 mm ($\frac{3}{8}$ in.) capillary break is not required for the successful drainage of EIFS and when compared to other cladding systems, “EIFS walls tended to retain the lowest amount of water despite allowing the water input to flow down entirely with the drainage cavities”²

In the drainage capacity test, three full size EIFS mock-ups are constructed, each measuring 1220 mm (48 in.) wide by 2134 mm (84 in.) high. Each test specimen is continually weighed during testing. The test consists of uniformly distributing water across the width of the test wall into the drainage cavity using a perforated metal tube and a serrated fiberglass mesh fabric that directs water onto the surface of the WRB. The water is applied at a rate of 8 L/hr for a period of one hour. At the end of the test, the average increased weight of the three test specimens must not exceed 40 g/m² (or a total of 104 g for the stated specimen size). This equates to approximately 0.10 L or only 1% of the applied water. The tests have demonstrated that EIFS systems with drainage cavities less than 10 mm ($\frac{3}{8}$ in.) can pass the stringent requirements of the Drainage Capacity Test in ULC S716.1.

While the vertical drainage of water within an EIFS is important, equally important is that the water is redirected back outside the wall system by flashings. Drainage of the cavity is achieved by continuous or intermittent (weep) openings along horizontal EIFS terminations at the bottom of the assembly, at selected horizontal expansion/control joints, and above and/or below flashed wall penetrations, such as windows, doors, louvers, exhausts and mechanical units. The drainage system must be carefully detailed and installed at interfaces to assure water is properly managed to drain to the exterior. Flashings and the integration of the WRB and EIFS are dealt with in more detail in Section 3.2, “Rainwater Penetration Resistance”.

² CMHC Report - Drainage and Retention of Water by Cladding Systems – Summary Report, March 30, 2007, Page 52.

2.3 Adhesive

In most EIFS, the thermal insulation board is attached to the substrate with an adhesive, a substance or compound used for bonding surfaces together; the alternative is the use of mechanical fasteners, which is discussed in Section 2.4.9. The adhesive is an integral part of the EIFS. As such, only the adhesive specified by the manufacturer of the EIFS must be used with a given system and a given substrate.

There are two generic types of adhesives used in EIFS: cementitious (those that contain Portland cement) and non-cementitious. Adhesives that contain Portland cement harden by the chemical reaction of the cement with water. Most often, the adhesive needs to be field-mixed. Field-mixed materials refers to those that are created on site by combining two or more materials, other than or in addition to water. Typically the adhesive is supplied as a paste, to which Portland cement is added. Cementitious adhesives are also available as factory-blended dry powders, to which water is added. Factory-blended refers to any material that arrives from the manufacturer requiring no additions apart from water to produce the wet state material.

Non-cementitious adhesives typically harden by the evaporation of water. They are typically single part materials requiring no additional ingredients (including water) in the field. The EIFS standards also allow the LA-WRB to be used as an adhesive to secure the thermal insulation board if it has been demonstrated to meet the requirements of the EIFS Materials Standard (*ULC S716.2, Clause 9.1.2*) for both components.

The adhesive must be compatible with both the insulation and the substrate, which includes the WRB, and it must provide adequate strength. Bond testing is conducted as part of the requirements of EIFS Materials Standard to demonstrate capacity to resist negative wind loads. The criteria for the bond testing ensures that the weakest part of the system is the insulation itself; that is, the insulation itself will fail cohesively before the system fails adhesively.

The properties required of an adhesive will vary for different substrates. Wood-based substrates (e.g., oriented strand board and plywood) will shrink and swell due to humidity changes resulting in movement at the joints. These substrates may require a more flexible adhesive. An EIFS manufacturer may, therefore, require the use of different adhesives depending on the substrate. The EIFS manufacturer's requirements for adhesive must always be followed to ensure the system performs as expected.

Adhesives are primarily applied in two different ways:

1. As a series of ribbons, applied with a notched trowel as specified by the manufacturer, or
2. Where geometrically-defined thermal insulation boards are used to provide drainage channels, flat trowels without notches may be used to apply the adhesive.

The pattern of the adhesive, and often the specific notched trowel to be used to achieve that pattern, will be specified by the EIFS manufacturer. The Manufacturer's published written installation instructions must be followed with respect to application of the adhesive (*ULC S716.2, Clause 9.1.5*). The pattern of adhesive, typically vertical ribbons, is intended to provide drainage channels for any water that penetrates the system. Some trowel-applied adhesives used to attach the insulation to the substrate may also perform as the secondary water resistive barrier and air barrier when fully coating the substrate. This topic is discussed in detail in Section 3.5, Air and Vapour Control.

The environmental conditions at the time the adhesive is applied and the temperature of the surface to which it is being applied are important considerations (*ULC S716.2, Clause 9.1.3*). The installation standard requires that the adhesive must not be applied:

- 1 When the ambient temperature is less than 4°C (40°F);
- 2 When the WRB or substrate surface temperature is less than 4°C (40°F);
- 3 When the WRB or substrate surface temperature is more than 40°C (104°F); or,
- 4 When the adhesive temperature is more than 40°C (104°F).

If necessary, auxiliary protection, such as tenting, shading or supplemental heat can be provided to ensure the appropriate environmental conditions are maintained for a minimum period of 24 hours before application of the adhesive, during application of the adhesive and for a minimum period of 24 hours after application of the adhesive (*ULC S716.2, Clause 9.1.4*).

2.4 Insulation

The insulation provided within the building envelope controls heat flow. This impacts building energy consumption, associated pollution and greenhouse gas emissions. Model building and energy codes outline requirements for thermal resistance of assemblies to separate interior and exterior environments and to achieve this while minimizing condensation within the assemblies.

While EIFS insulation can be used primarily as an aesthetic cladding, it is usually part of the thermal resistance control strategy for the wall assembly. As mentioned at the outset of this Manual, one of the greatest advantages of EIFS from a building science perspective is that the insulation is placed outboard of the building structure, providing the following benefits:

- Subject to limitations based on fire testing, EIFS can solely provide the thermal resistance required to meet the National Energy Code of Canada for Buildings;
- Thermal bridging is minimized, improving overall energy efficiency;
- The structural members remain at a consistent temperature, which improves their expected longevity;
- Thermal movements of the structural members of the building are minimized, resulting in fewer problems of cracking of interior or exterior finishes; and,
- Minimizing the potential for interstitial condensation due to vapour diffusion. An adequate thickness of EIFS insulation is required to achieve this while avoiding or minimizing framed cavity wall insulation.

2.4.1 Material

In EIFS, the insulation is typically foam plastic, most often expanded polystyrene (EPS). Other insulation materials that may be used include extruded polyurethane, polyisocyanurate and mineral fibre. The EIFS Materials Standard requires thermal insulation board used with EIFS to meet the requirements of either CAN/ULC-S701, Annex A, “Standard for Thermal Insulation, Polystyrene, Boards and Pipe Covering” or CAN/ULC-S704, “Standard for Thermal Insulation, Polyurethane and Polyisocyanurate, Boards, Faced” (*ULC S716.1, Clause 4.1.2*). Mineral fibre thermal insulation board must meet the requirements of CAN/ULC-S702, “Standard for Mineral Fibre Thermal Insulation for Buildings” with a surface density of at least 96 kg per m³ for lamella mats and 128 kg per m³ for board stock.

2.4.2 Integral Part of the EIFS

The insulation incorporated within the EIFS forms an integral part of the EIFS, and must have:

- Appropriate physical properties to perform within the system;
- Stability, dimensional tolerances, etc.;
- Adequate compatibility and bond to adhesives and base coats;
- Adequate strength to resist wind and impact loads; and
- Adequate fire resistance properties.

The shear stiffness of the insulation is also important to the performance of the lamina. The insulation must have sufficient flexibility (i.e., a low enough shear stiffness) to act as a buffer for differential movement to occur between the substrate and the lamina, such as may occur with

thermal expansion and contraction, providing an ability for the system to accommodate movements without cracking (see Figure 6).

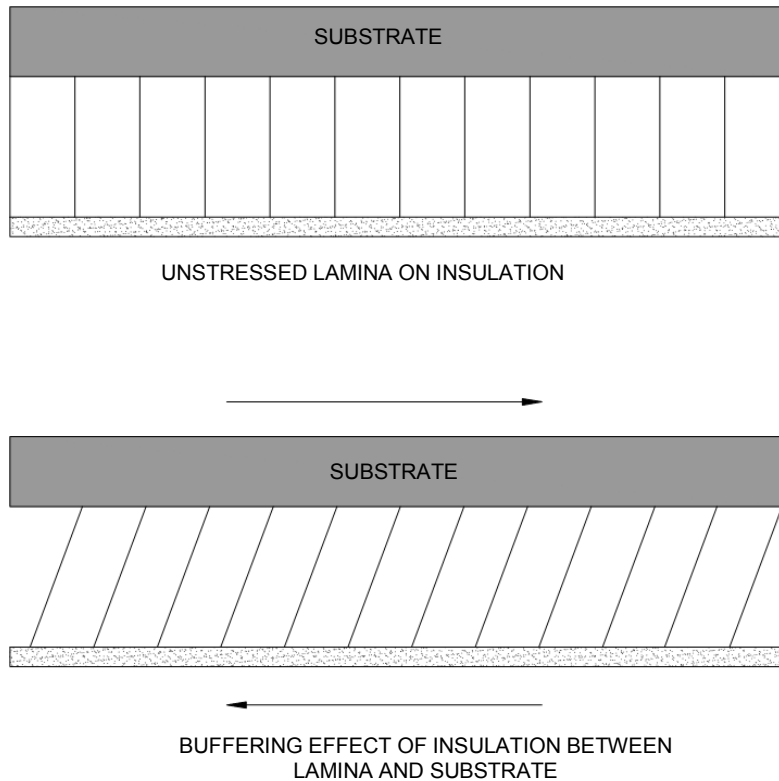

Figure 6: Insulation buffering effect accommodates movement to avoid cracking of lamina.

EIFS manufacturers will specify the insulation that must be used with their system. Substitute insulation must not be used, as only the specified insulation will have been tested to the EIFS Material Standard and will be assured of meeting expected performance (*ULC S716.2, Clause 4.1*). For example, substituting a more rigid insulation than specified by the manufacturer could result in cracking of the lamina.

This point is so critical, that Clause 4.1 of the EIFS Installation Standard specifically requires that an installed EIFS consist only of the material and components specified by a single EIFS manufacturer as meeting the requirements of the EIFS Materials Standard.

CAUTION!

2.4.3 Thickness

Locating all the thermal insulation outboard of the structure is considered best practice. Subject to limitations based on fire testing, EIFS can solely provide the thermal resistance required to meet the minimum thermal resistance values and/or performance levels in the National Energy Code of Canada for Buildings. When insulation is required in the stud space to supplement the thermal resistance provided by the EIFS, there may be potential for condensation within the wall assembly. In designing the wall system, it is necessary to properly account for the risks of vapour condensing within the wall assembly. A hygrothermal analysis by a qualified professional should be performed for complex wall assemblies, when additional insulation within the stud cavity is

considered and/or when the exterior insulation thickness is minimized. (See Chapter 3 for further information on cladding design.)

Both the EIFS Installation and Design Standards require that the minimum thickness of thermal insulation board is 25 mm (1 in.) (prior to rasping). This thickness is exclusive of any patterns or drainage grooves cut into the back of the insulation. The required thickness may be reduced behind an aesthetic reveal to a minimum of 20 mm ($\frac{3}{4}$ in.) excluding the thickness of the GDCC if incorporated into the EIFS (*ULC S716.2, Clause 9.4.2; ULC S716.3, Clause 5.1.3*) (see Figure 7).

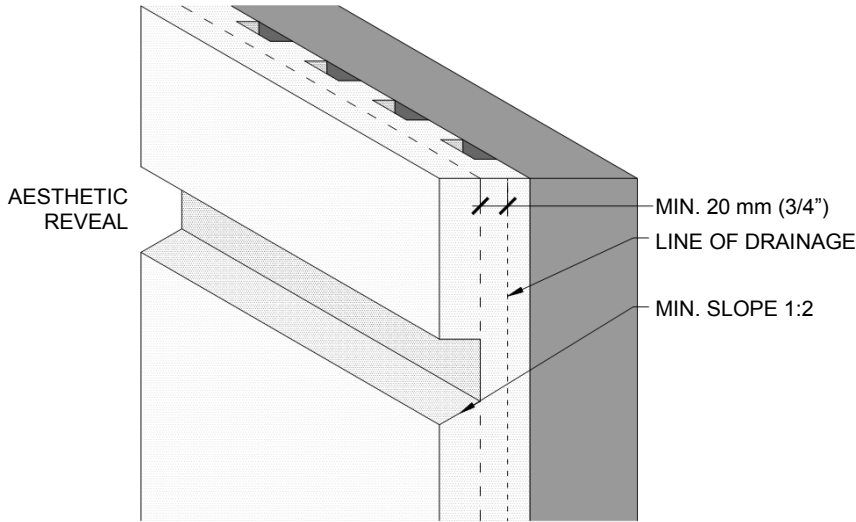

Figure 7: Minimum Insulation Thickness at Reveal

EIFS are noted for the ability to create three-dimensional features by cutting the insulation or adding additional layers prior to finishing with the lamina. Where such architectural profiles are desired, they should be achieved through the use of thicker thermal insulation boards or the adhesion of additional layers of thermal insulation boards (*ULC S716.2, Clause 9.2.1.12*). However, there are limitations to the maximum thickness of thermal insulation board that can be used. These limitations are related to fire safety requirements (see Section 3.1). In such cases, the thickness of the insulation cannot exceed the maximum tested thickness, including the thickness of mouldings or architectural profiles. As maximum tested limits vary between 50 mm (2 in.) and 150 mm (6 in.) or even greater, the manufacturer must be consulted to identify the limit for a particular system. To achieve a larger profile, the wall framing can be extended to reduce the insulation thickness required to achieve the desired profile (see Figure 8).

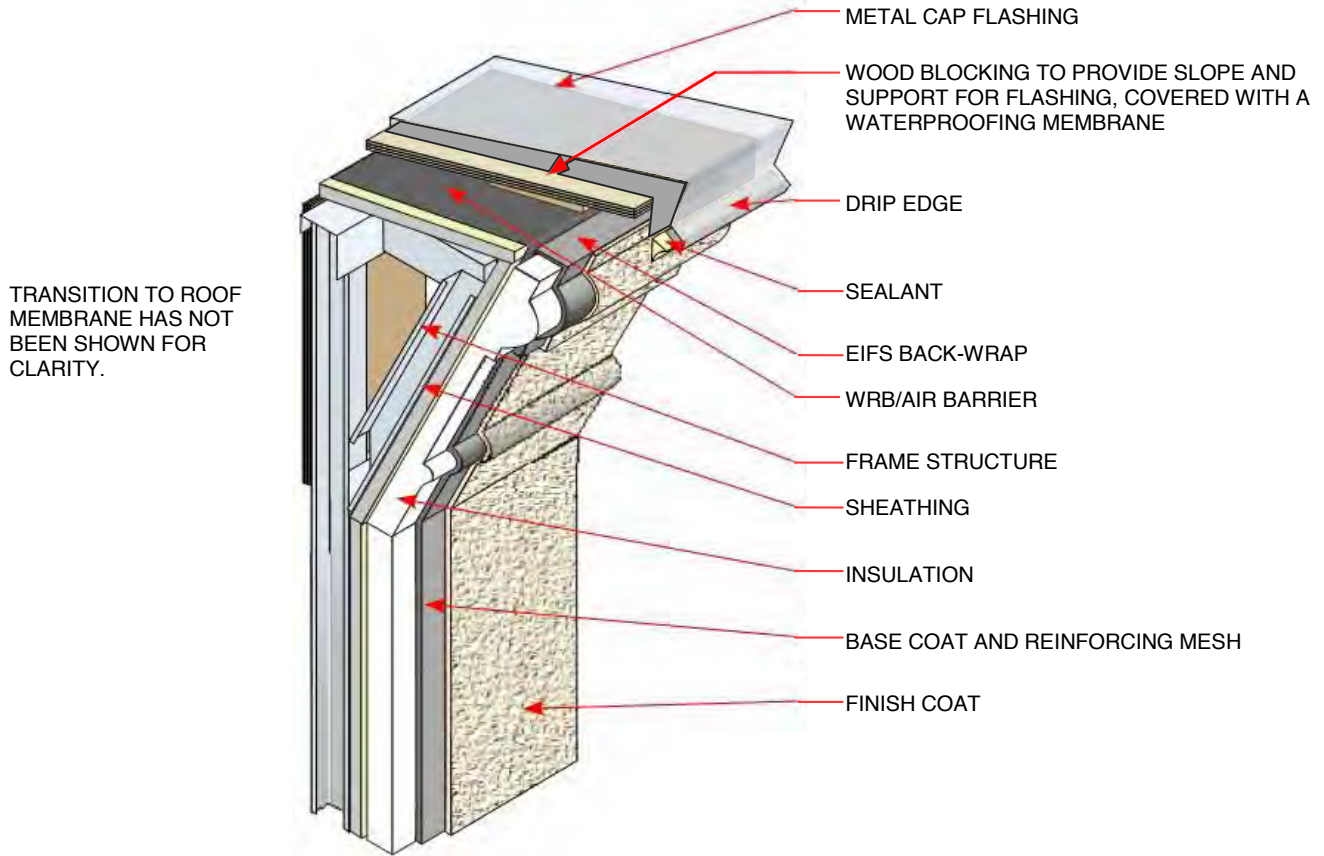

Figure 8: Illustration of a Framed Cornice

2.4.4 Application

The placement of the thermal insulation boards is important in preventing cracking of the lamina. The boards should be placed from a level base line with vertical joints staggered in a running bond pattern offset by a minimum of 75 mm (3 in.) (see Figure 9) (*ULC S716.2, Clause 9.2.1.2*). The insulation board joints should also be offset from horizontal and vertical substrate sheathing board joints by at least 150 mm (5 in.) (see Figure 9) (*ULC S716.2, Clause 9.2.1.6*). In addition, the insulation should be spaced to avoid joints at the locations of aesthetic reveals.

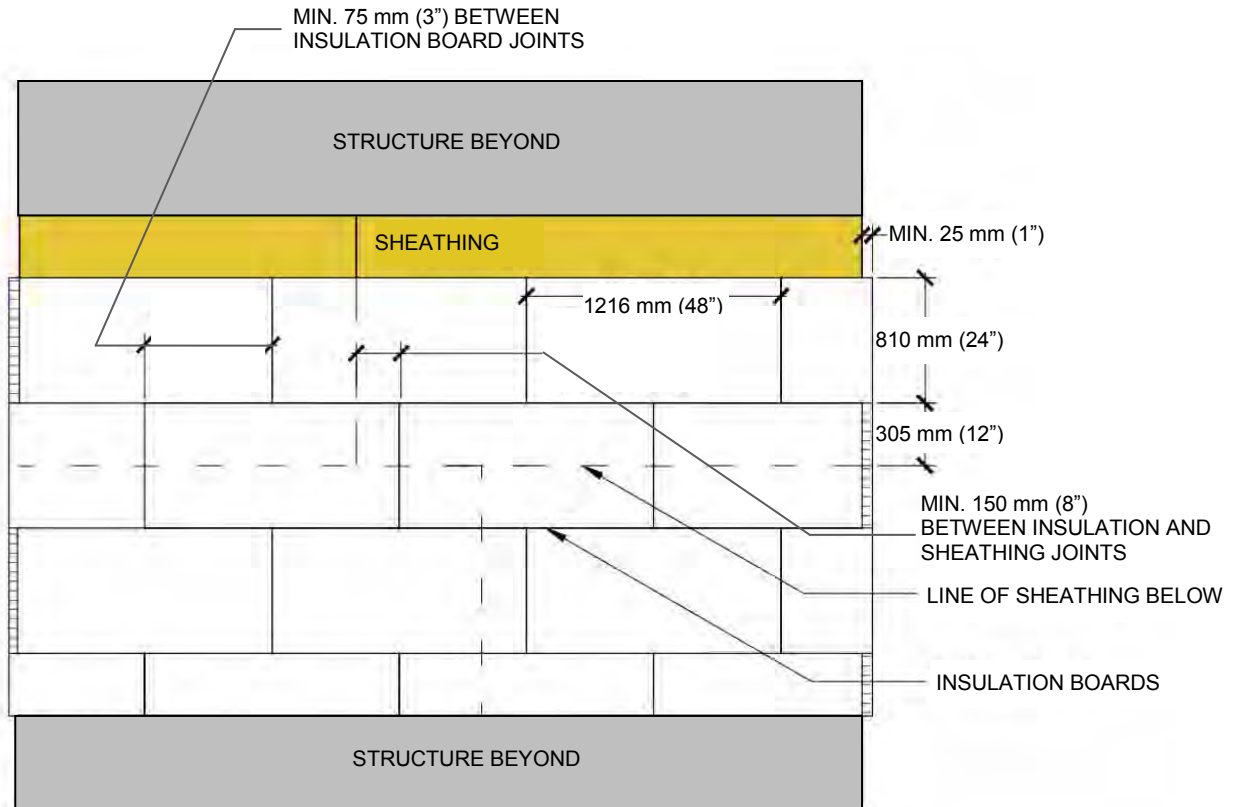

Figure 9: Insulation Boards Installed in Running Bond Pattern (Note: Dashed lines represent sheathing joints.)

The thermal insulation boards shall be butted tightly together to prevent the creation of stress concentrations and to prevent adhesive or base coat intrusion between the board edges (*ULC S716.2, Clause 9.2.1.3*). Before the base coat is applied, the EIFS Installation Standard requires any and all gaps exceeding 1.6 mm ($\frac{1}{16}$ in.) to be filled with insulation. Gaps larger than 3.2 mm ($\frac{1}{8}$ in.) must be filled with slivers of EPS (or mineral fibre, if it is a system that uses mineral fibre insulation). Smaller gaps may be filled with slivers of insulation, or for EPS systems, with single component, moisture-cure, low expansion rate, spray-in-place polyurethane foam that meets the requirements of CAN/ULC-S710.1, “Standard for Thermal Insulation – Bead-Applied One Component Polyurethane Air Sealant Foam, Part 1” (*ULC S716.2, Clause 9.3.1*). Such foam is usually supplied in pressurized cans and must be installed in accordance with CAN-ULC-S710.2-05, “Standard for Thermal Insulation – Bead-Applied One Component Polyurethane Air Sealant Foam, Part 2” (*ULC S716.2, Clause 9.3.2*).

Care must be taken to apply a sufficient thickness of insulation into the gaps without voids and without blocking drainage cavities. It is recommended that the use of spray foam be minimized at horizontal gaps and that slivers of EIFS insulation are used instead.

Stress concentrations that can cause cracking of the lamina generally originate from corners at wall penetrations. To minimize the risk of cracking, all sharp corners of openings penetrating the EIFS, such as at windows, must be framed with a solid piece of insulation. This typically

requires the use of L-shaped insulation pieces, (see Figure 10) (*ULC S716.2, Clause 9.2.1.5*). Continuous vertical joints in the insulation boards at building corners should also be avoided to reduce the potential for cracking. Interlocking or staggering the insulation, (see Figure 11) helps to resist corner cracks (*ULC S716.2, Clause 9.2.1.4*).

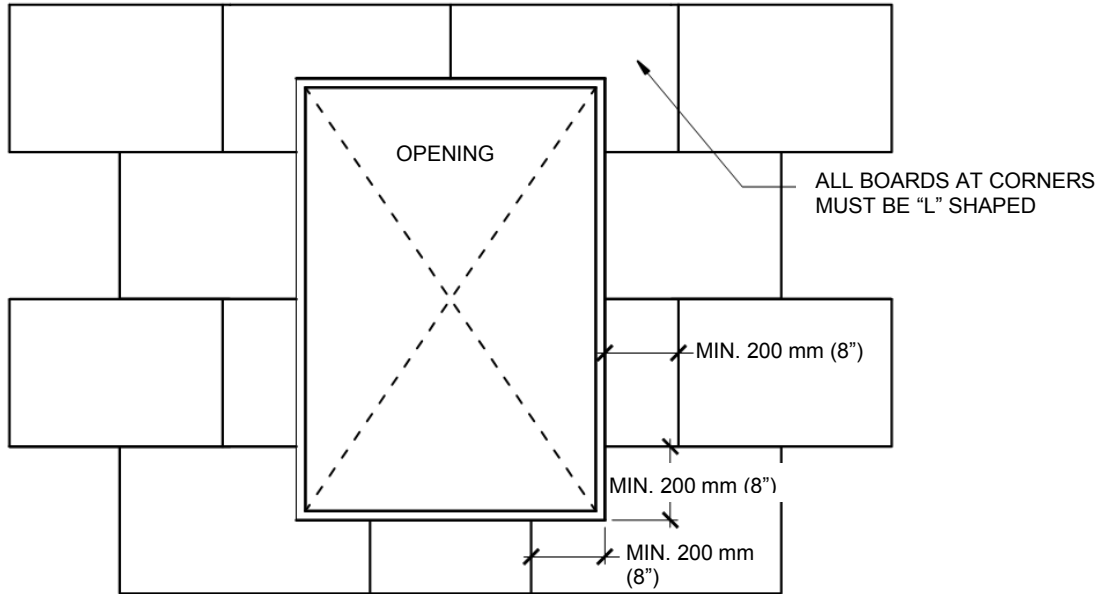

Figure 10: Insulation joint layout around openings.

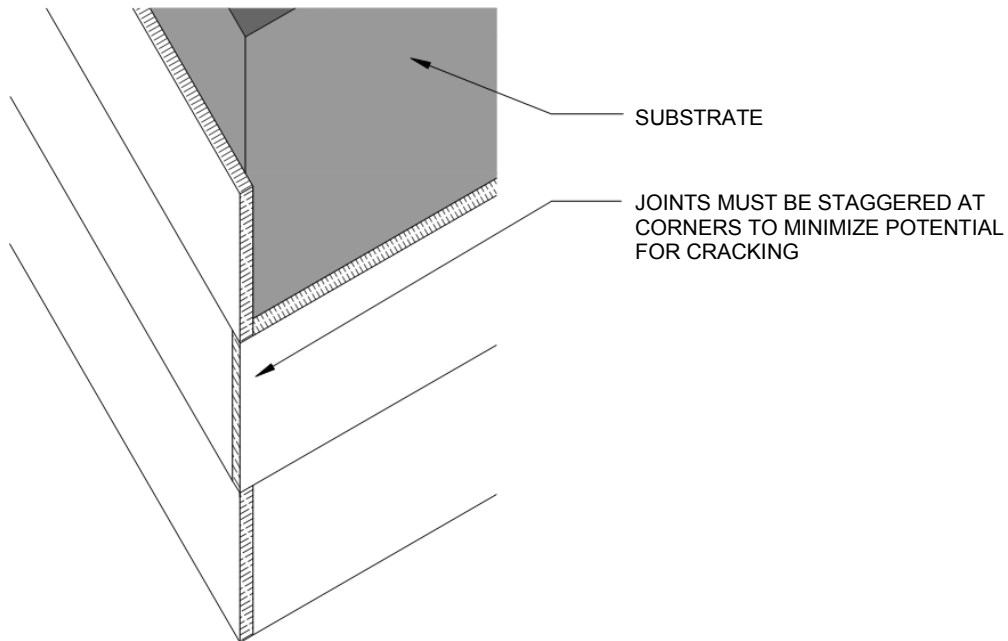

Figure 11: Insulation joint layout at corners.

As each thermal insulation board is installed, it should be placed tightly against the adjoining thermal insulation board without repositioning (*ULC S716.2, Clause 9.2.1.7*). Pressure needs to be applied over the entire surface of the thermal insulation board to help assure uniform contact is made with the adhesive and to obtain an overall level surface (*ULC S716.2, Clause 9.2.1.8*). When placing and applying pressure to the insulation boards, care is required so that the continuity of the drainage cavity is maintained (*ULC S716.2, Clause 9.2.1.1*). To ensure that a good bond is achieved, the thermal insulation board must be installed within the maximum time limit specified in the Manufacturer's published written installation instructions (*ULC S716.2, Clause 9.1.6*).

The thermal insulation board must be occasionally checked for proper contact, pattern, minimum cavity depth (in accordance with manufacturer drainage test results), continuity and adhesion with the substrate by removing a piece and examining the adhesive on the board. Proper contact is achieved when approximately equal portions of the adhesive remain on both the substrate and the thermal insulation board.

Where a board has been removed to verify the installation, the old adhesive needs to be totally removed from the thermal insulation board and new adhesive applied before the board can be replaced (*ULC S716.2, Clause 9.2.1.9*) to check for adequate adhesion (which is different from contact), the thermal insulation board should be checked by periodically removing boards following drying of the adhesive. An indication of good adhesion occurs when the EPS insulation beads are pulled off the board and remain attached to the adhesive. The adhesive should not pull cleanly off the WRB nor should the adhesive pull cleaning off the insulation board. Generally, the insulation should be very difficult to remove resulting in damage to the boards. The cavity depth can be measured at the board edge prior to removal.

As explained further in Section 3.3, there must be expansion joints incorporated into an EIFS wall to accommodate expansion and contraction of building materials. When the thermal insulation board is installed, consideration must be given to the planned location of these expansion joints, to ensure there is a sufficient gap between the boards. A minimum clearance of 20 mm ($\frac{3}{4}$ in.) must be provided for expansion joints. This minimum clearance must be provided after the installation of the base coat and reinforcing mesh, meaning that the insulation boards must be placed further apart than 20 mm ($\frac{3}{4}$ in.) to allow for the thickness of the given EIFS (*ULC S716.2, Clause 9.2.2.3*). At other joint locations where significant expansion is not expected, such as at junctions with other claddings or at windows, a minimum clearance of 13 mm ($\frac{1}{2}$ in.) must be provided after the installation of the base coat and reinforcing mesh (*ULC S716.2, Clause 9.2.2.2*).

2.4.5 Geometrically Defined Drainage Cavity (GDDC) Insulation

To allow for water drainage behind the insulation (more on drainage in Section 2.2.11 and 3.4), EIFS manufacturers provide systems that incorporate a geometrically defined drainage cavity (GDDC), using insulation boards that have grooves or shapes cut into their back surface to create drainage channels. Such insulation and the shape and pattern of the insulation are typically proprietary in nature. Therefore, the manufacturer's published written installation instructions must be followed.

The thermal insulation boards shall be installed in such a manner that the continuity of the drainage cavity is maintained (*ULC S716.2, Clause 9.2.1.1*).

2.4.6 Rasping

Before the base coat and reinforcing mesh are applied, the entire surface of the thermal insulation board must be rasped (sanded). The purpose of the rasping is to:

1. Ensure that the surface of the insulation is flat and with square edges;
2. To ensure all visible UV degradation of the foam plastic insulation is removed; and,
3. To improve the adhesive bonding of the base coat to the insulation.

It is important that the surface of the insulation is flat primarily for aesthetic reasons. The EIFS Installation Standard requires that the surface is flat to within ± 3 mm ($\frac{1}{8}$ in.) in 1220 mm (4 ft.) in any direction across flat wall areas. The EIFS Installation Standard also requires that there is no planar difference between thermal insulation boards at joint locations. It is important, however, that the thickness of the insulation is not reduced to less than 20 mm ($\frac{3}{4}$ in.) when the rasping is complete. If there are significant variations in the substrate surface, it may be necessary to use thicker insulation in some locations to ensure that the minimum 20 mm ($\frac{3}{4}$ in.) is maintained after rasping (*ULC S716.2, Clause 9.3.3*).

The UV radiation from sunlight causes degradation of the surface of plastic thermal insulation board. The visible sign of UV degradation is a yellow powder on the surface of the thermal insulation board. The presence of such degradation will affect the bonding of the base coat to the insulation. Therefore, rasping is used to remove any visible surface degradation to help ensure a good bond is achieved between the insulation and the base coat (*ULC S716.2, Clause 9.3.4*).

It is important that the thermal insulation board adhesive be cured or dried before rasping is commenced to ensure that the insulation does not shift or the adhesive loosen due to the rasping. The EIFS Installation Standard requires that the thermal insulation board is not rasped for at least 24 hours after it is installed. In cool, damp weather, it may be necessary to extend this time even longer to allow the insulation board to become sufficiently bonded (*ULC S716.2, Clause 9.2.1.10*). However, the EIFS Installation Standard does allow the time until rasping to be reduced if the manufacturer has a proprietary adhesive that sets up more quickly (*ULC S716.2, Clause 9.2.1.11*). If such an adhesive is used, the Manufacturer's published written installation instructions must be followed.

Cementitious adhesives cure rather than dry and are less dependent on humidity and temperature. Polymer adhesives dry and drying time is affected by humidity, temperature, and the vapour permeability of the insulation and WRB.

2.4.7 Other Considerations

There are two final considerations regarding the insulation. First, foam plastic insulation should not be used where it will be exposed to excessive heat that may cause it to melt. For this reason, the EIFS Installation Standard prohibits the use of EIFS containing foam plastic insulation when:

- 1) Closer than 50 mm (2 in.) to heat emitting devices or exhausts (*ULC S716.2 Clause 9.2.2.4*); and,
- 2) At locations where a service temperature in excess of +66°C (150°F) may be expected, such as a dark colour that absorbs solar radiation. The only exception to this requirement is if the specific EIFS has been designed for use at higher service temperatures, as specified in the Manufacturer's published written installation instructions (*ULC S716.2, Clause 4.5*).

Second, foamed plastic insulation has been found to be a desirable medium for termite travel. At grade, there is a risk of termite or other insect penetration and/or upwards migration. Terminating the EIFS a minimum of 200 mm (8 in.) above grade can help reduce the risk of insect ingress by allowing for visual inspection for evidence of termites. Care in the location of drainage holes, or the incorporation of a sheet metal flashing with sealed joints at the at-grade termination (taking care not to block drainage paths) can also improve protection from insects.

2.4.8 Aesthetic Reveals

An aesthetic reveal is a groove cut into the insulation board that serves the function of decoration. It may also provide a starting or stopping point for the application of the finish coat, so that there are no noticeable changes in the appearance of the finish coat such as might occur if a day's work was stopped in the field of the EIFS.

Aesthetic reveals in EIFS are formed by cutting into the insulation after rasing, but prior to applying the base coat and reinforcing mesh (*ULC S716.2, Clause 9.4.1*). However, in cutting the grooves, the reduction in insulation thickness can create a weak area, which is susceptible to cracking. To avoid excessive weakening at reveals, the cut grooves should be limited to a depth of no more than 20 mm ($\frac{3}{4}$ in.) and a minimum of 20 mm ($\frac{3}{4}$ in.) of insulation shall remain behind the reveal (as measured from the bottom of the aesthetic reveal to the back side of the thermal insulation board, not to the substrate) (*ULC S716.2, Clause 9.4.2*). Aesthetic reveals should not be located at joints in the thermal insulation board (*ULC S716.2, Clause 9.4.4*), nor should reveals be aligned with the corners of windows or other openings, to avoid creating areas of great stress concentration which could lead to cracking of the lamina.

The reinforcing mesh must be continuous through aesthetic reveals and must be fully embedded within the base coat within the aesthetic reveal (*ULC S716.2, Clause 10.2.1.5*). Care must be taken in the installation of the mesh in a reveal that the mesh isn't damaged or cut, such as by the corner of a trowel. Rounded or U-shaped reveals are generally preferable over square or V-cut grooves, (see Figure 12) as it is much harder to get the mesh into such reveals without causing damage to the mesh. The bottom surface of horizontal reveals must be capable of shedding precipitation and must have a minimum positive outward slope of 1:2, (see Figure 13) (*ULC S716.2, Clause 9.4.3*).



Figure 12: Ideal aesthetic reveal profiles (Left: Semi Rounded, Right: Trapezoid).

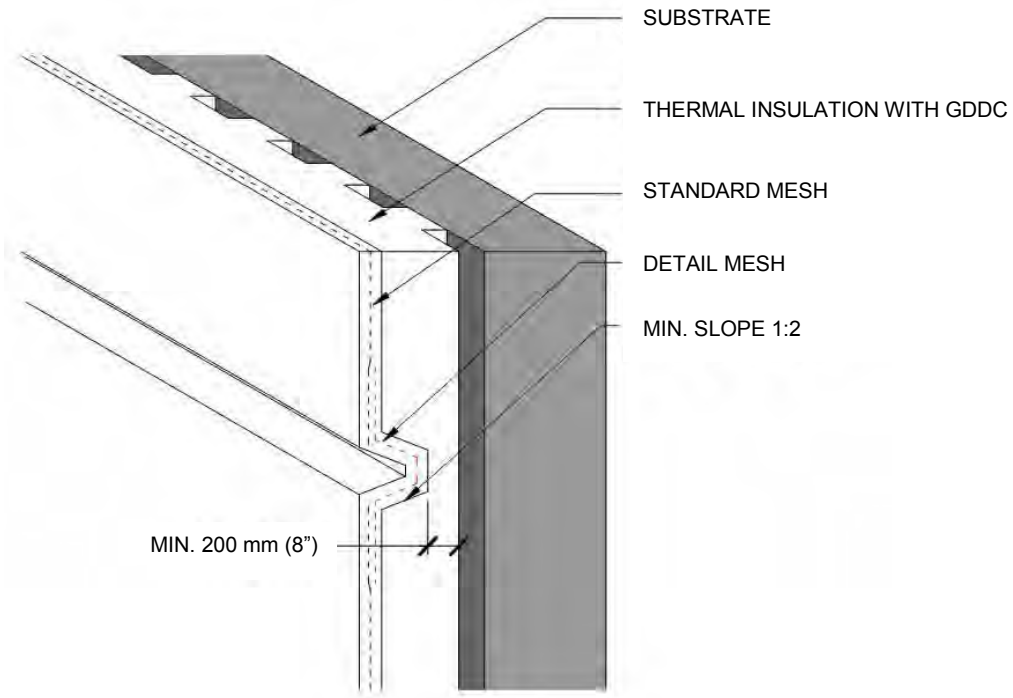

Figure 13: Horizontal reveal.

2.4.9 Mechanical Fasteners

The use of mechanical fasteners is currently outside the scope of the EIFS Standards, but is recognized in those standards as an acceptable complement and/or as an alternative to adhesive for attachment (*ULC S716.1, Clause 1.3*). For example, some mineral wool systems require mechanical fasteners for attachment of the mineral fibre board insulation. Mechanical fasteners are also required if adhesive attachment is difficult or impossible because of the condition of the substrate, such as when using plastic film-coated self-adhering membranes or sheathing wrap weather resistive barriers, as most applied adhesives do not adhere to these materials. The use of mechanical fasteners may also be required in a retrofit application, for example if removal of existing paint is not practical and an alternate attachment surface or method is required.

Some EIFS manufacturers make use of mechanical fastening as the primary or secondary means of attaching the insulation to the substrate. Manufacturers typically use proprietary fasteners with their systems. These could be metal screws or power-driven pins that pass through a plastic washer. The washer is important because it spreads the force of the fastener over a wider area, reducing the stress on the soft insulation. One of the possible modes of failure is for the insulation to be pulled right through the fasteners due to negative wind load, leaving the fasteners stuck in the wall; the washers help prevent this from happening but create a line of shear through the insulation at the perimeter of the washer. Plastic washers should be used because they do not corrode and conduct little heat. While the fasteners are typically metal because of the strength required, it is important that they be corrosion resistant. Some manufactures make washers specifically for the installation of EIFS and are able to provide fastener patterns and installation instructions.

Where mechanical fasteners are used, it is recommended that the EIFS, in addition to meeting the requirements of the EIFS Materials Standard for individual components, is also evaluated for suitability based on the following criteria:

- a) Corrosion resistance properties of the fasteners;
- b) Pull out strength of the fasteners from the substrate;
- c) Pull out of washer through the insulation;
- d) Wind load resistance of the system, as per Annex C of CAN/ULC S716.1;
- e) Moisture sensitivity of the substrate; and,
- f) Effect of penetration of the LA-WRB by fasteners on its water penetration resistance.

Corrosion Resistance

Where mechanical fastening of the EIFS insulation is employed, there is a risk of moisture exposure of the fasteners, which varies along the fastener length. Fastener wetting may occur if water penetrates or accumulates within the building envelope or if thermal bridging of the fasteners results in condensation on and near the surface of the fastener. Therefore, mechanical fasteners must be corrosion resistant and used in conjunction with a non-metallic washer. Hot dipped galvanizing is the minimum protection that should be provided; best practice is to use non-corroding fasteners, such as stainless steel, to secure the insulation.

Fastener Pull-Out Strength and EPS Fracture

The positive pressure created when wind blows on a building tends to push the EIFS against the substrate, providing additional support to the EIFS. However, the leeward walls of a building are exposed to negative, or suction, wind loads, which are typically higher than the positive wind loads on a building. The negative wind loads tend to pull the EIFS away from the substrate, creating pressure on the back of the washers, which then is transferred to the fasteners. If the forces applied to the fasteners are greater than their pullout strength, or their ability to grip the substrate, the EIFS and the fasteners may pull off the wall. The strength of the fasteners as installed in the substrate is typically related to the type of substrate and the depth of penetration into the substrate.

In most cases, mechanical fasteners are installed into framing that has the strength to support the fasteners with a pull-out strength not less than that required by the manufacturer of the fasteners for a particular substrate. As a general rule of thumb, fasteners should penetrate at least 8 mm ($\frac{5}{16}$ in.) into steel framing members, 25 mm (1 in.) into wood framing members, and 25 mm (1 in.) into sound masonry/concrete substrates (see Figure 14). Alternatively, shorter fasteners can be installed into plywood or OSB sheathing board, rather than into the framing, but only if such fasteners fully penetrate the sheathing board and only if wind-load testing by the EIFS manufacturer is provided that substantiates the performance using shorter fastener lengths.

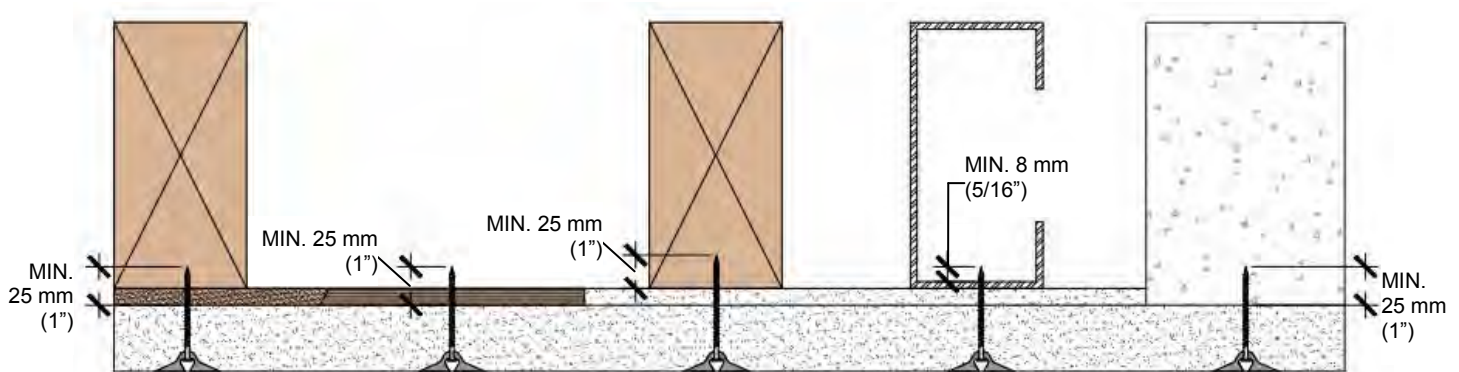

Figure 14: Fastener anchorage depth.

Fastener pull-out from the substrate is extremely rare. Also rare, but more common than fasteners pulling out of the substrate, is the fracture of EPS insulation at the fastener/washer connection. Fasteners/washer connections can also be weakened by over stressing the base of the washer during installation (particularly with mineral wool systems).

Wind Load Resistance

Wind load resistance is closely related to fastener pull-out strength. Unlike adhesive, which is continuous over the surface of the insulation creating a very strong wind load resistance, a mechanical fastener holds the insulation at a point, meaning that the force of the wind is concentrated at that point. There must be a sufficient number of fasteners spread at appropriate distances such that the force applied by the wind on any one fastener does not exceed its individual capacity.

Selection of type and spacing of fasteners will depend on substrate type and flexibility, insulation board thickness, design wind load and whether the fasteners are used in combination with an adhesive attachment.

Fasteners must be installed sufficiently close together to resist the design wind loads. This spacing is a function of not only the pull-out resistance of the fastener as discussed above, but also the failure load of the insulation-to-washer connection; if this connection is insufficient, the wind may pull the EIFS off the wall, leaving the fastener (and washer) connected to the building.

In many instances, the distance between framing members prescribes the horizontal spacing of fasteners. Decreasing the spacing between framing members to allow the installation of more fasteners may increase the wind-load resistance. The flexibility of the substrate also affects the pull-off forces of the wind; the use of a stiffer substrate will help improve wind resistance. For high wind loads and wide fastener spacing, the ability of the insulation itself to carry the loads laterally to the fasteners should be tested. Typically, the insulation is the weakest part of the EIFS. Therefore, fastener type, installation patterns, and use must be in accordance with the Manufacturer's published written installation instructions, which must be consistent with wind-load testing performed by the EIFS manufacturer. Further, the fastener type and installation patterns must be included in the project plans and specifications. In some instances, thicker insulation may be needed for structural reasons.

Wind-load resistance testing of EIFS that incorporate mechanical fasteners is outside the scope of the EIFS Materials Standard, meaning that it is not necessary to pass a wind-load resistance test to meet the standard. However, a method to conduct wind load testing is provided in Annex H of the EIFS Design Standard (*ULC S716.1, Clause 5.5.5.1*). The test method involves the construction of a wall at least 2.44 m (8 ft.) high and 2.44 m (8 ft.) wide. The wall is subjected to positive and negative wind loads at three maximum pressure levels for three different modes of wind pressure application:

- sustained wind load (longer duration, lower maximum pressure);
- cyclic wind load (shorter duration, fluctuating medium pressure); and,
- gust wind load (short duration, high maximum pressure).

Deflection measurements are recorded to aid in evaluation the effectiveness of the mechanical fasteners.

Washer Positioning

For EIFS, the outside face of the washer and screw head must be flush with the outside face of the insulation. The base coat and reinforcing are then applied over the washer. This means that the washer must be slightly recessed without fracturing the surrounding insulation board. The recess should not be more than 3.2 mm ($\frac{1}{8}$ in.) once final rasping (sanding) is complete; otherwise, a thickening of the base coat will be caused, which can result in cracks. On the other hand, if the fastener protrudes, it will create a visible bump in the finish and/or push the mesh too close to the exterior of the base coat. Note that installing the washer flush with the insulation means that wind loads are transferred from the lamina through the EPS before being taken up by the washer and screw fastener.

2.5 Base Coat

2.5.1 Material

The base coat is a thin (1.6 mm to 2.5 mm or $\frac{1}{16}$ in to $\frac{3}{32}$ in.) coating applied directly to the thermal insulation board. The base coat is the primary barrier (first plane of protection) to water penetration, so its water impermeability is tested as part of the EIFS Material Standard by subjecting one side of a sample of base coat to water; to pass the test, less than 90% of the back of the sample can be damp after two hours. The water absorption of the base coat is also tested by evaluating the dry weight of a sample specimen before and after exposure to water; to pass the test, the base coat must not increase in mass more than 20% after 48 hours immersion in water.

Although base coat formulations vary by manufacturer, they all contain three primary constituents: polymer technology, aggregates, and water. Most also contain some amount of Portland cement. The base coat can be supplied as a dry-mix or as a compound. Dry-mixed base coats only require the addition of water, whereas wet mixes may require the addition of Portland cement.

2.5.2 Bond Strength

The adhesion of the base coat to the insulation is critical to the long-term performance of the EIFS. The bond strength of the base coat to the insulation is evaluated as previously described for evaluating the bond of the LA-WRB to the substrate (Section 2.2.2). The bond strength of the base coat must be ≥ 80 kPa for all test states - Initial, Wet and Dry (*ULC S716.1, Subsection 5.3.3 and Annex A*). To put this requirement into perspective, the highest hourly wind speed for a 1 in 50 year occurrence listed in the National Building Code, which occurs at Resolution Island, Nunavut, is only 1.23 kPa. The internal shear strength of foam plastic insulation is approximately 90 to 100 kPa; therefore, it would be difficult to evaluate the bond strength of the base coat at a higher strength, as the insulation would cohesively fail during the testing before the base coat bond gave way.

2.5.3 Application

The surface of the thermal insulation board shall be inspected by the mechanic prior to the installation of the base coat to ensure that it is clean, dry and free of foreign materials. Any damaged thermal insulation board must be replaced with undamaged insulation and rasped before the base coat is applied. There should be no visible UV degradation, which manifests as a yellow powder on the surface of the thermal insulation board; UV degradation can be removed by rasping (*ULC S716.2, Clause 10.1.1*).

The prepared base coat is uniformly spread onto the surface of the thermal insulation board at the thickness recommended by the manufacturer. The Manufacturer's published written installation instructions for base coat thickness should be followed to ensure the base coat is installed with sufficient thickness to completely coat and encapsulate the reinforcing mesh (discussed more in the next section). While a base coat that is too thin and that does not fully encapsulate the reinforcing mesh is undesirable, a base coat that is too thick or uneven is equally undesirable, as such can cause cracking and differential water absorption. Further, a thicker base coat alone does not achieve greater crack resistance; a significant increase in base coat thickness must be coupled with a relative increase in mesh weight and strength.

The recommended installation method is to apply the base coat in two (or more) applications unless otherwise specified by the Manufacturer's published written installation instructions (*ULC S716.2, Clause 10.3, Note*). Specifying that the base coat must be applied with a minimum of two passes also helps to reduce the risk for deviations in workmanship that result in locally deficient thickness.

Where the reinforcing mesh is applied, the base coat applied to the insulation for each section of mesh is to cover an area greater than the size of mesh so that the mesh does not lay directly on the surface of the insulation resulting in improper embedment (*ULC S716.2, Clause 10.1.4*). The reinforcing mesh and its installation are discussed further in Section 2.6.

The base coat will experience slight shrinkage during drying, resulting in a dry thickness that is typically less than the wet thickness. The EIFS Installation Standard requires that the total dry thickness of the reinforced base coat, as measured from the surface of the thermal insulation board, not be less than the minimum specified by the EIFS manufacturer as complying with the requirements of CAN/ULC-S716.1 or 1.6 mm ($\frac{1}{16}$ in.), whichever is greater (*ULC S716.2, Clause 10.3.1*). Further, in meeting these minimum dry thickness requirements, the thickness may not be averaged over any given area. Following testing to the EIFS Materials Standard, the dry thickness of the test samples used for evaluating the water impermeability and water absorption of the base coat is measured, so the expected shrinkage of the material can be gauged.

A wet mil gauge is typically used to measure the thickness of coatings in construction. However, with EIFS, because of the interference of the mesh, such a measurement for the base coat is not possible. Destructive testing would be required to verify the dry thickness of the installed base coat during construction.

Typically the application thickness is routinely checked by visual review. The reinforcing mesh pattern is permitted to be visible however the colour of the mesh shall not be visible (*ULC S716.2, Clause 10.3.2*). The mesh pattern generally becomes slightly visible due to differential drying of the base coat applied over the coloured mesh (*ULCS716.2, Clause 10.3.2, see note*).

2.6 Reinforcing Mesh

2.6.1 Materials

Reinforcing mesh is used to improve the mechanical properties of the base coat. It must be compatible with the coating system in which it is to be embedded and typically consists of alkali-resistant glass fibres (wherein glass fibre mesh is coated with alkali-resistant polymers, such as acrylic), to prevent the deterioration of the glass fibre by cementitious compounds in the base coat).

The mesh may be either woven or non-woven. The use of self-adhering reinforcing mesh is not permitted by the EIFS Installation Standard (*ULC S716.2, Clause 10.1.5*).

2.6.2 Strength and Alkalinity Resistance

As the reinforcing mesh is used to improve the mechanical properties (i.e., strength) of the base coat, the EIFS Materials Standard requires that the strength of the reinforcing mesh be rigorously tested. And since the alkaline environment of the base coat could reduce that strength, the strength of the reinforcing mesh is also tested after exposure to an alkaline environment (*ULC S716.1, Clause 5.3.10*).

2.6.3 Installation

The mesh must be fully embedded into the wet base coat throughout the field of the wall, and at corners, edges and joints (*ULC S716.2, Clause 10.1.7.A*). The mesh must be installed with sufficient pressure to ensure that it will have no contact with the finish coat at the top, but without causing it to contact the insulation at the bottom (*ULC S716.2, Clause 10.1.7.B*). The base coat must be sufficiently thick to completely coat and encapsulate the reinforcing mesh to seal the mesh from contact with both the finish coat and the insulation. If a complete coating is not provided, the mesh will not be protected from deterioration and a true composite will not be formed.

As it is practically impossible to install the mesh in one continuous piece, it will be necessary to cut the reinforcing mesh fabric into manageable sizes for installation. A weak area prone to cracking would be created if the pieces of reinforcing mesh were simply butted up against each other. To improve the strength of the lamina and prevent cracking, all edges of reinforcing mesh pieces should be overlapped at least 65 mm, or more if required by the Manufacturer's published written installation instructions (*ULC S716.2, Clause 10.1.9*). The thickness of the base coat can be adjusted at the mesh overlap to hide the joints between pieces of mesh, provided each layer of mesh is still properly embedded.

The only exception to this requirement is when a layer of reinforcing mesh is added to provide impact resistance greater than 10 Joules (90 in.lb.). In this case, the extra fabric sections should not be overlapped, but should be butted tightly together and the base coat allowed to harden, followed by application of a second layer of base coat and installation of the EIFS manufacturer's standard weight reinforcing mesh, overlapped the standard 65 mm (2 1/2 in.) or more (*ULC S716.2, Clause 10.1.6*).

The reinforcing mesh must be continuous at all wall corners (interior or exterior) and shall overlap at least 200 mm (8 in.) onto each wall face, as shown in (*ULC S716.2, Clause 10.1.10 and Illustration 21-25*). This overlap prevents cracking at such locations.

The reinforcing mesh must also be continuous through aesthetic reveals and must be fully embedded within the base coat within the aesthetic reveal (*ULC S716.2, Clause 10.2.1.5*). Care must be taken in the installation of reinforcing mesh in a reveal that the mesh is not damaged or cut, such as by the corner of a trowel. Care must also be taken to avoid applying too little or too much base coat to encapsulate the mesh at reveals since this can result in cracking. The use of rounded or U-shaped reveals is generally preferable over square or V-cut grooves to avoid these conditions.

Similar to other claddings, the corners of wall openings, such as for windows, doors or HVAC penetrations, are locations of stress concentrations that can cause cracking of the lamina. To prevent such cracking, extra reinforcing mesh must be installed at the corners of returns to windows, doors and similar wall openings for the full width of the return and extending not less than 65 mm (2 1/2 in.) on the face of the wall, (see Figure 15), (*ULC S716.2, Clause 10.1.12*). The corners of the openings should also be reinforced with diagonal strips of reinforcing mesh before the field mesh is installed. The reinforcing strips, (see Figure 15) should be at least 230 mm (9 in.) wide, 300 mm (10 in.) long, and applied at 45° angles to the corners. The inside corners of the openings also require strips of mesh to maintain continuity unless continuity is maintained without added additional strips. Similar to the reinforcing mesh in the field of the wall, the extra reinforcing strips need to be embedded in the base coat; they should be trowelled from the center to the edges to avoid wrinkles (*ULC S716.2, Clause 10.1.11*).

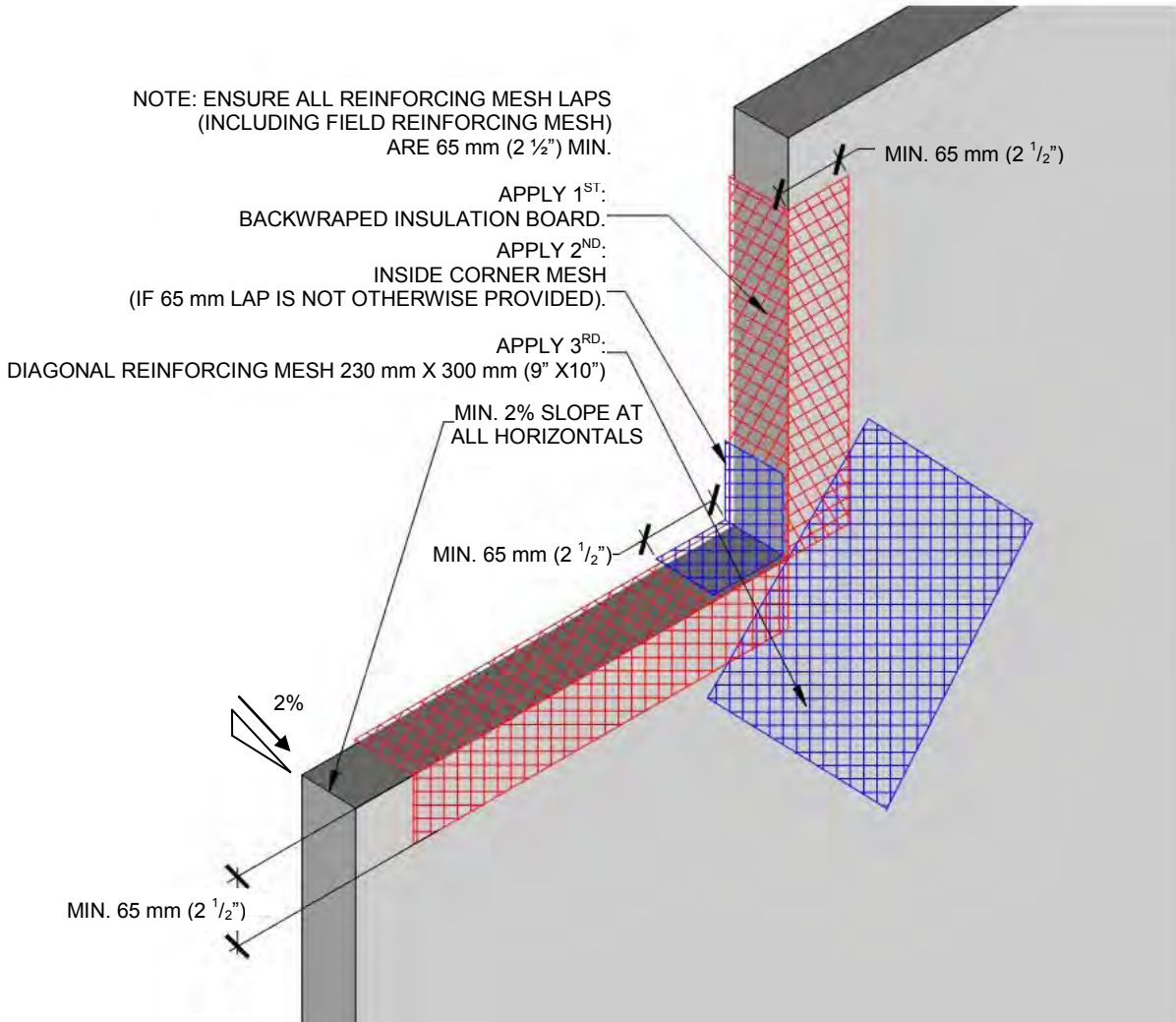

Figure 15: Reinforcing mesh detailing at openings.

The reinforcing mesh should be installed immediately following the application of the initial base coat material, while the base coat is still wet. The base coat should be smoothed by trowelling, beginning at the centre of the reinforcing mesh and continuing outward (*ULC S716.2, Clause 10.1.7.C*). Care must be taken to ensure the reinforcing mesh remains free of wrinkles or other anomalies that prevent the reinforcing mesh from being flat to the thermal insulation board on all planes (*ULC S716.2, Clause 10.1.7.D*). The reinforcing mesh must not be cut to remove a wrinkle, unless the cut area is overlapped with undamaged reinforcing mesh at least 65 mm (2 1/2 in.) on either side of the cut (*ULC S716.2, Clause 10.1.8*). Excess base coat material should be trowelled off to make the surface smooth (*ULC S716.2, Clause 10.1.5*).

When properly embedded, the reinforcing mesh colour should not be visible through the base coat, though the reinforcing mesh pattern may be visible (see Figure 16). When the base coat dries, it will experience some shrinkage, which may result in the reinforcing mesh pattern becoming more visible. The differential drying of the base coat due to the difference in base coat thickness caused by the intervening thickness of the mesh may also cause the base coat to appear to be a different colour over the reinforcing mesh; this is a different condition than the case where the mesh is not sufficiently embedded and the colour of the mesh is still visible through the base coat (*ULC S716.2, Clause 10.3.1*).



Acceptable Base Coat Coverage



Inadequate Base Coat Coverage



Base Coat Applied Too Thickly

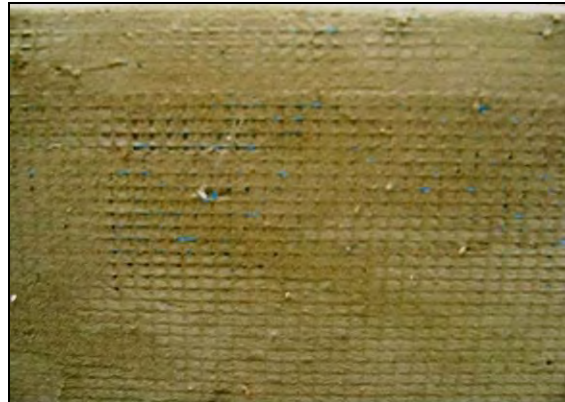

Inadequate Base Coat Coverage

Figure 16: Application thickness of base coat over reinforcing mesh.

It is important that all terminations in the thermal insulation board, such as junctions with other cladding systems, are wrapped with base coat and reinforcing mesh. There are different methods to accomplish the termination wrapping, which are discussed in Section 2.9, “Terminations”.

2.7 Finish Coat

The finish coat is applied to the base coat, which together with the reinforcing mesh, forms the lamina. The finish coat provides EIFS with its colour and texture. While the base coat provides the water resistance of the EIFS cladding, the finish coat provides “weather” resistance; the finish coat sheds water without damage to its appearance and resists other environmental factors which could change its appearance, such as UV radiation, dirt, and road salt spray.

Quality finish coats often include pigments, aggregates and additives that resist dirt pickup and mould growth. The size and grading of the aggregates and the method used to apply the finish coat allow for a wide range of surface texture, while pigments provide an almost unlimited range of colours.

2.7.1 Materials

Polymer based textured acrylic coatings are the most common EIFS finish. The texture is governed by the size of the aggregate and trowel motion on the wall. However one of EIFS greatest advantages is the wide range of speciality finish options available in addition to the standard finishes. A sampling of finishes is depicted in the images below and on the pages that follow.



Stone Aggregate



Metallic



Stone



Stone



Combination



Combination



Masonry



Masonry



Masonry



Mosaic



Mosaic



Retrofit – Original Deteriorated Brick



Retrofit – EIFS Simulated Stone

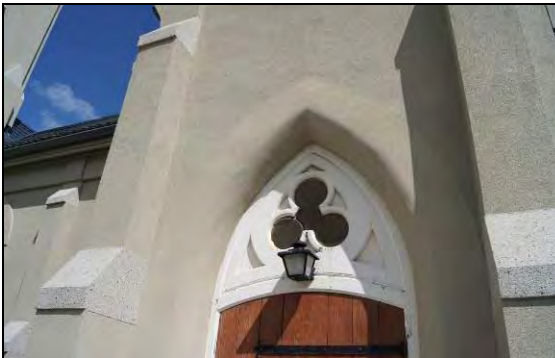

Retrofit – EIFS Simulated Stone



Retrofit – EIFS Simulated Stone Aggregate



Texture



Texture

2.7.2 Bond Strength

The ability of the finish coat to bond to the base coat is evaluated as part of the testing requirements of the EIFS Materials Standard (*ULC S716.1, Clause 5.3.3.1*), similar to the bond strength tests of all the other EIFS components. The only exception is that the bond strength of the finish coat to the base coat need only be ≥ 80 kPa in any state to meet the requirements of the EIFS Materials Standard.

As a result, the finish coat should not be applied onto surfaces that are to receive sealant, as the sealant is likely to exert a greater load than the finish coat can resist. In addition, when sealant is applied to a textured finish coat, the sealant does not fill all the recesses of finish (especially when not properly tooled) allowing water to penetrate and soften the finish over time which weakens the sealant bond (see also Section 2.9 on Terminations).

CAUTION!

2.7.3 Colour Retention

The selection of finish coat colours will impact maintenance of the cladding, as brightly coloured organic pigments or non-earth tone colours, such as blues and reds, tend to be more vulnerable to fading over time as compared with earth tones. If a bright coloured finish is desired, the building owner should be prepared for more frequent re-coating to renew appearance. More durable earth tone colours using inorganic pigments should be considered for areas where access for re-coating is difficult or costly. Consideration should be given to the application of a colour primer over the base coat prior to finish coat application (see 2.7.4 Colour Primers).

In hot climates, dark colours, such as dark green and brown, are likely to become warm with solar heating, and in conjunction with reflectivity from surrounding surfaces might present a concern with softening of foam plastic insulation. *Note: There are no documented cases of such an occurrence in Canada.*

2.7.4 Colour Primers

Some manufacturers may require the application of a colour primer prior to the application of the finish coat. The use of a primer should be specified if the use of a primer is allowed by the manufacturer. The Manufacturer's published written installation instructions should be followed with respect to application of the primer (*ULC S716.2, Clause 11.1.1*).

A colour primer can be used to enhance the finish coat application by providing the following benefits:

- Increases colour retention and minimizes fading issues (especially for darker colours). A colour primer is usually recommended for darker colours.
- Increases the coverage rate while reducing the rate drying of the finish coat (especially if a light coloured primer is used in the summer as a result of reduced evaporation). Reducing the drying rate could be a problem if precipitation is expected.
- Improves the consistency of the finish coat and texture.

- Enhances the water-repellant properties of the lamina (may reduce the vapour permeability of the lamina which could be a disadvantage for certain climate zones and buildings with high humidity).
- Is useful at joints to be caulked since the textured finish coat does not need to be applied tight to the sealant to conceal the base coat colour.
- Can protect the base coat from efflorescence (that can result from exposure to precipitation) until the finish coat is applied.
- Can function similar to a sealer and can prevent alkalinity of the base coat from adversely affecting the colour consistency of the finish.

Key Benefit

2.7.5 Mould and Fungus Resistance

If exposed to frequent wetting, staining by mildew growth can result. Frequent wetting can occur where the EIFS is not effectively protected from rain, or in high humidity climates where areas are not exposed to direct sunlight (north elevations, shaded areas, etc.).

To help ensure mildew growth does not occur, the finish coat is required by the EIFS Materials Standard to undergo a fungus resistance test. The test involves coating a glass slide with the finish coat and incubating it for a period of 28 days, at the end of which there must be no fungal growth when the slides are examined at 40X magnification (*ULC S716.1, Clause 5.3.7*).

2.7.6 UV Resistance

The finish coat is required to resist ultraviolet radiation. However, the EIFS Materials Standard requires testing of the entire lamina for UV resistance, so this requirement is discussed in Section 2.8 under Lamina.

2.7.7 Application

The Manufacturer's published written installation instructions should be followed with respect to mixing the finish coat and the addition, if required, of clean, potable water to adjust workability (*ULC S716.2, Clause 11.1.4*). The Manufacturer's published written installation instructions should also be followed with respect to application of the finish coat, including its thickness, to ensure that the desired texture and appearance is attained (*ULC S716.2, Clauses 11.2.1 and 11.2.5*). A stainless steel trowel, or other appropriate equipment as specified by the Manufacturer's Written Installation Instructions, should be used to install the finish coat (*ULC S716.2, Clause 11.2.4*).

The finish coat should not be installed until the base coat is fully dry. The Manufacturer's published written installation instructions should be referenced to determine base coat drying time based on climatic conditions, mixing and application practices. However, in no case is the finish coat to be installed less than 24 hours after the installation of the base coat unless materials are specifically designed to allow for early application. It should be noted that conditions of high humidity could extend the time required for drying to occur, particularly for cementitious base coat materials (*ULC S716.2, Clause 11.1.2*).

The Manufacturer's published written installation instructions should be followed with respect to application of the colour primer if used (*ULC S716.2, Clause 11.1.1*).

The finish coat should only be applied to the clean surface of the primer or base coat (*ULC S716.2, Clause 11.1.3*). In addition, similar to all other EIFS component materials, the environmental conditions at the time the finish coat is applied and the temperature of the surface to which it is being applied are important considerations (*ULC S716.2, Clause 11.2.2*). The EIFS Installation Standard requires that the finish coat should not be installed:

1. When the ambient temperature is less than 4°C (40°F);
2. When the base coat surface temperature is less than 10°C (50°F);
3. When the ambient temperature is more than 40°C (104°F);
4. When the base coat surface temperature is more than 40°C (104°F); or,
5. When the finish coat material temperature is more than 40°C (104°F).

The temperature of the applied material shall also be above 4°C (40°F).

If necessary, auxiliary protection, such as tenting, shading and supplemental heat can be provided to ensure the appropriate environmental conditions are maintained for a minimum period of 24 hours before application of the finish coat, during application of the finish coat and for a minimum period of 24 hours after application of the finish coat (*ULC S716.2, Clause 11.2.3*). The finish coat must be protected from rain until it is fully dry to avoid damage to the final appearance (*ULC S716.2, Clause 11.2.6*).

2.8 Lamina

The lamina is the composite layer installed over the insulation, comprised of the base coat, reinforcing mesh and finish coat.

2.8.1 Water Vapour Permeance

The EIFS Materials Standard requires determination of the water vapour permeance of the lamina. This is simply a measure of the rate of water vapour transmission through the lamina. A lower permeance means that less water vapour will pass through the lamina.

A test specimen of lamina that has been carefully removed from the insulation is used for the test. The test is conducted according to ASTM E96, “Standard Test Methods for Water Vapor Transmission of Materials” (*ULC S716.1, Clause 5.3.4.2*). The test specimen is sealed, face coat down, to the open mouth of a test dish containing desiccant. The test dish is then placed in a controlled chamber with a temperature of 23°C (73 °F) and 50% relative humidity. Over time, vapour will move from the test chamber through the lamina and into the desiccant. This arrangement simulates the movement of water vapour from inside the building through the lamina to the exterior, such as might occur during the winter. The test dish and specimen is periodically weighed and compared to its initial weight to determine the amount of moisture that has been absorbed by the specimen and the desiccant until the rate of water transmission is steady. The result is reported in ng/(Pa·s·m²) (*ULC S716.1, Clause 5.3.4.3*). As the permeance depends on the overall thickness of the lamina, the dry thickness of the lamina is measured in five locations and the average thickness is reported (*ULC S716.1, Clause 5.3.4.1*).

There is no pass/fail criteria for water vapour permeance in the EIFS Materials Standard. The test is conducted because the permeance could be an important factor in the cladding design with respect to vapour control (more about designing for vapour control can be found in Section 3.5.1).

2.8.2 Salt Spray Resistance

The lamina is also subjected to a salt spray resistance test as part of the testing required in the EIFS Materials Standard (*ULC S716.1, Clause 5.3.8*). In this test, conducted in accordance with ASTM B117, “Standard Practice for Operating Salt Spray (Fog) Apparatus”, three small specimens (100 mm x 300 mm or 4 in. x 12in.) of the lamina and insulation are subjected to a 5% sodium chloride salt solution spray for a period of 300 hours. At the end of the test, none of the samples should exhibit any visible aspect of deterioration or deleterious effects, such as cracking or flaking. The intent of the test is to demonstrate the resistance of the lamina to the effects of road salt spray, or salt water spray where the EIFS may be installed near an ocean or other bodies of salt water.

2.8.3 Resistance to UV Radiation

The ultraviolet resistance test that the lamina is subjected to as part of the requirements of the EIFS Materials Standard is far more severe than that required of the LA-WRB. Three test specimens (each 100 mm x 300 mm, or 4 in. x 12 in.) that include the lamina and insulation are subjected to cycles of both UV radiation and water spray for a total period of 2500 hours as per ASTM G155, “Standard Practice for Operating Xenon Arc Light Apparatus for Exposure of Non-Metallic Materials” (*ULC S716.1, Clause 5.3.9*). The test of the LA-WRB involves exposure for a period of only 336 hours. The light source used to simulate the UV radiation in testing the

lamina is also a much stronger source than that used for testing the LA-WRB. Of course, the lamina is expected to be exposed to long term UV radiation, unlike the LA-WRB, which will be covered for most of its life expectancy. To demonstrate resistance to UV radiation, the tested specimens must demonstrate no deleterious effects, such as cracking or flaking, following the test exposure.

2.8.4 Durability Under Environmental Cycling

To provide an indication of the expected performance of the EIFS over time, the EIFS Material Standard requires a specially designed test specimen to be subjected to simulated extreme cyclic environmental conditions. This test is really a test of the entire EIFS, not just the lamina.

A full-scale test specimen (minimum 3 m by 3 m, or 9 ft. 10 in by 9 ft. 10 in.) is constructed according the Manufacturer's published written installation instructions on a steel framing assembly. The steel framing and sheathing assembly is specified simply to provide a standard backing for the EIFS; the test is conducted solely to evaluate the performance of the EIFS. The steel framing is, however, designed to be flexible under the applied test loads to evaluate the effect of mechanical stress on the EIFS. Design and construction elements that can affect the long term performance of the EIFS, namely a vertical and a horizontal expansion joint, a window opening and typical service penetrations (one square, one round, and one hexagonal), are incorporated into the test specimen, (see Figure 17).

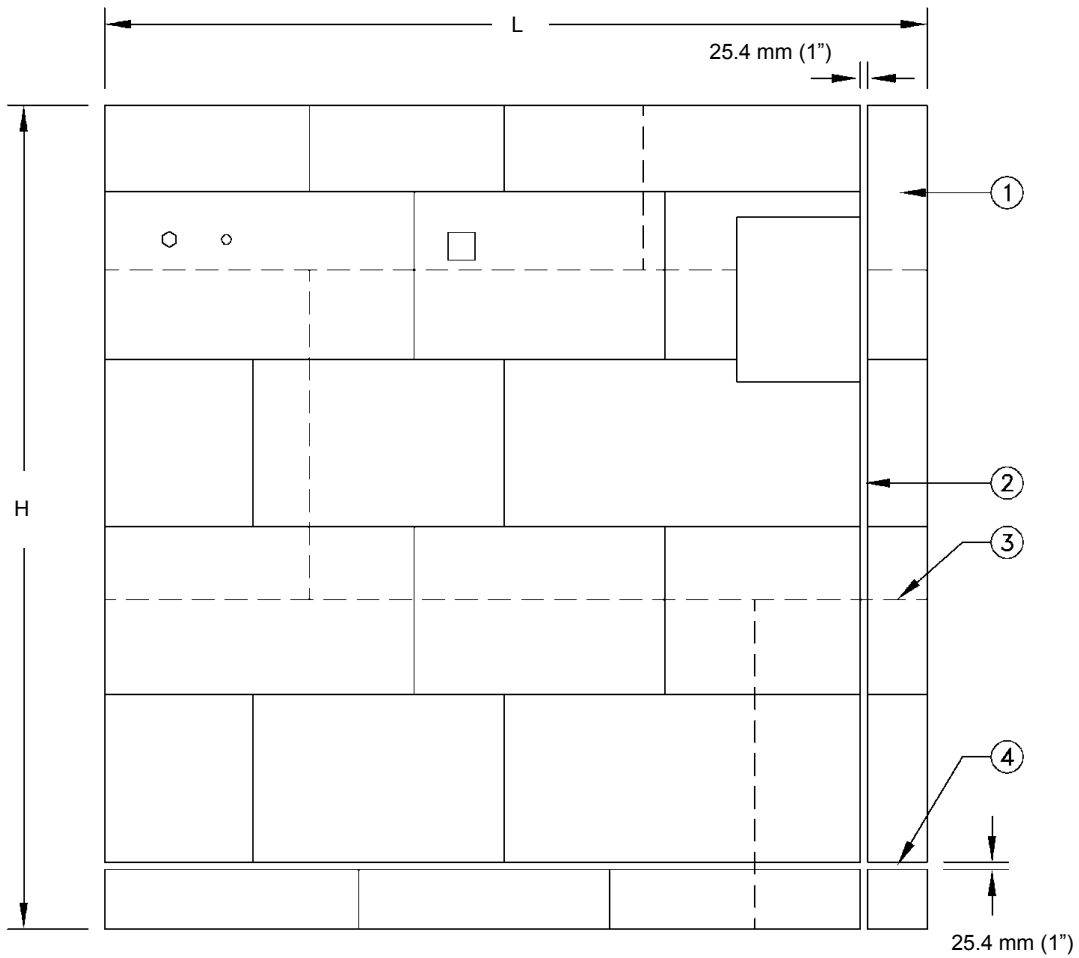

- 1 - HEXAGONAL
- 2 - CIRCULAR, 30 mm (1 ½ in.) DIAMETER.
- 3 - SQUARED, 100 mm X 100 mm (4 in. X4 in.).
- 4 - THERMAL INSULATION BOARD
- 5 - WINDOW
- 6 - VERTICAL JOINT.
- 7 - SHEATHING BOARD JOINTS.
- 8 - HORIZONTAL JOINT.

Figure 17: Durability test specimen.

So that it is not necessary to construct a separate test specimen for each of the manufacturer's constituent components, the test specimen is constructed of those components that are expected to represent a "worst-case" scenario, namely:

- The EIFS manufacturer's LA-WRB with the weakest bond strength in the wet state and the highest water absorption;
- The EIFS manufacturer's adhesive with the weakest bond strength to both the thermal insulation board and to the LA-WRB in the wet state; and
- The EIFS manufacturer's base coat with the highest water absorption coefficient and the weakest bond strength in the wet state.

By incorporating these "worst-case" constituent components into the test specimen, all the other manufacturer's components are deemed to meet the test. Where it is not possible to construct one test specimen that incorporates the "worst-case" constituent materials thus identified, it may be necessary to construct and test additional test specimens. For example, if the EIFS manufacturer has different LA-WRBs and one has the weakest bond strength in the wet state and another has the highest water absorption, it would be necessary to construct two test specimens, one with the different LA-WRB.

To evaluate the base coat independently of the finish coat, the finish coat is omitted from one half of the test specimen, (see Figure 18).

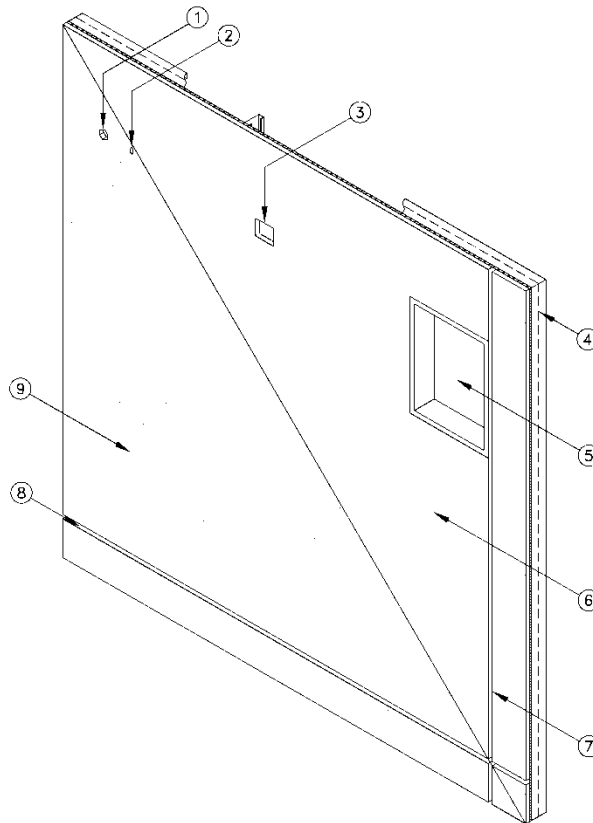

Figure 18: Durability test specimen.

The test specimen is mounted into a test apparatus consisting of a room environmental chamber on one side and a weather environmental chamber on the other side. The conditions in the room environmental chamber are kept at approximately 23 °C and 50% r.h. throughout the test. The weather chamber is capable of achieving temperatures between -20 °C (-4 °F) and +66 °C (150 °F), applying a static air pressure difference of ± 1200 Pa, and subjecting the wall to water spray, all to evaluate the effect of hygrothermal (water and temperature) stresses on the EIFS cladding.

Prior to the actual environmental cycling, the wall undergoes some preconditioning. Since water retained in the cladding can have an adverse effect on long-term performance, in the preconditioning stage, water is introduced into the top of the drainage cavity on the surface of the LA-WRB for a period of two hours. The water is allowed to drain, but any water that is retained within the assembly after the two hours remains there for the environmental cycling stage.

In the environmental cycling stage, the temperature in the environmental chamber is raised from room temperature to 66 °C (150 °F) over the course of an hour. The temperature is then maintained at 66 °C (150 °F) for a period of one hour while a negative pressure of 1200 Pa is maintained across the wall (such that that hot air from the weather chamber is pulled through the wall into the room chamber). Over the course of the next two hours, the temperature is dropped from +66 °C (150 °F) to -20 °C (-4 °F). For the first hour while the temperature is dropping, the wall is also subjected to a positive pressure difference of 1200 Pa and water spray. The environmental chamber is maintained at a temperature of -20 °C (-4 °F) for a period of one hour while subjected to a negative pressure of 1200 Pa. The temperature is then raised to room temperature over a period of one hour while being subjected to a positive pressure difference of 1200 Pa. This cycle, represented in Figure EUI, takes a total of six hours. The cycle is repeated four times per day for a total of 15 days, or 60 cycles.

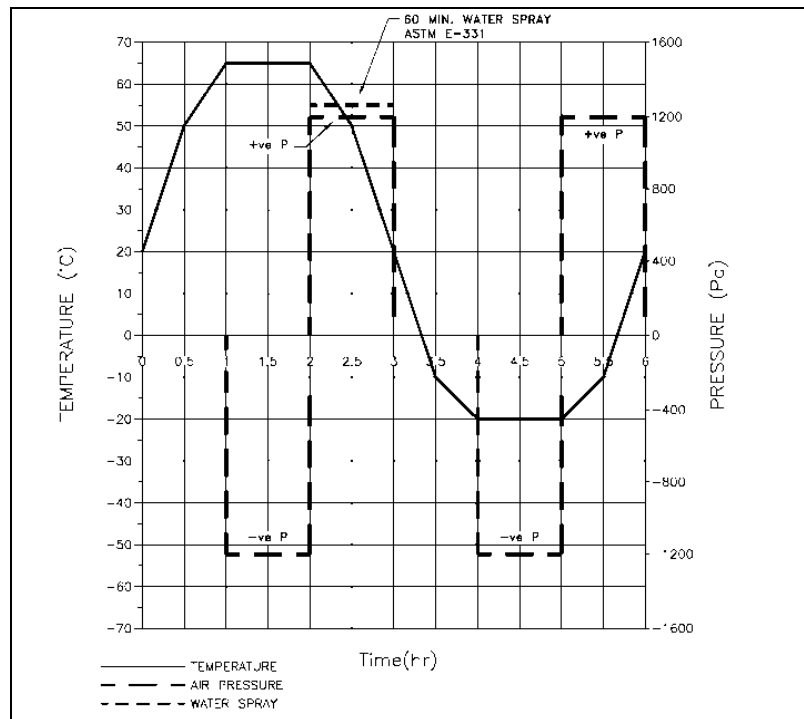

Figure 19: Details of one cycle of the environmental conditions imposed for the durability under environmental cycling test.

At the end of the test, the test specimen is observed for failure, where failure is defined as:

- Loss of adhesion between the finish coat and the base coat;
- Blistering of the finish coat;
- Cracking, blistering, crazing or sagging of the base coat (excluding crazing or microcracking);
- Separation of the base coat from the insulation;
- Changes in colour or texture of the finish or base coat (excluding crazing or microcracking); or
- Water that passes through to the substrate.

If there are no visible signs of failure, cores are cut from the test specimen and subjected to a bond strength test to determine if there has been any drop in the bond strength of any of the constituent materials. The specimen is deemed to have passed this test if the decrease in bond strength compared to previously tested specimens is not more than 20%.

This test does not produce an estimate of the expected service life of the cladding. It simply provides an indication of the expected performance of the EIFS over time.

2.9 Terminations and Wrapping

A termination refers to any location where the EIFS ends such that an exposed edge of thermal insulation board might occur, such as at a junction between the EIFS and another cladding material, at an expansion joint, or at a penetration, such as a window, door, duct, pipe or electrical box. The thermal insulation board must be protected at all terminations through wrapping (*ULC S716.2, Clause 10.2.1.1*).

Wrapping is defined as the application of reinforcing mesh and base coat to the exposed edges of the insulation board. The purpose of wrapping is:

- 1) To protect the thermal insulation board from external moisture sources (i.e. rain and snow);
- 2) To encapsulate and secure the insulation board to the substrate (including under fire conditions);
- 3) To serve as a substrate for sealants; and,
- 4) To provide a finished appearance.

There are three methods for wrapping a termination.

Back-wrapping (ULC S716.2, Clause 10.2.2.3)

Prior to the installation of the thermal insulation board that will need to be wrapped, a starter strip of reinforcing mesh of appropriate size and weight is applied to the substrate with a continuous application of adhesive excluding horizontal terminations designed to drain water. The starter strip must extend behind the thermal insulation board by at least 65 mm (2 ½ in.). After the thermal insulation board is installed and the base coat is applied to the edge and face of the thermal insulation board, the starter reinforcing mesh is wrapped around the thermal insulation board and embedded into the base coat on the edge and face of the thermal insulation board. The starter reinforcing mesh and the reinforcing mesh in the field of the EIFS must overlap by at least 65 mm (2 ½ in.), or the minimum required mesh overlap for the system if it is greater than 65 mm (2 ½ in.). Back-wrapping enhances the attachment of the insulation board to the substrate. Figure 20 shows a horizontal cross section, or a vertical termination, such as might occur at a window jamb.

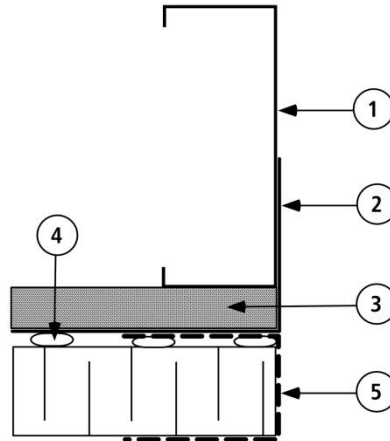

1. STRUCTURAL SUPPORT.
2. LIQUID APPLIED WATER RESISTIVE BARRIER (TO BE REINFORCED AT THIS LOCATION).
3. SUBSTRATE.
4. ADHESIVE ATTACHMENT.
5. BASE COAT AND REINFORCING MESH.
6. THERMAL INSULATION BOARD.

Figure 20: Back-wrapping plan view – mesh applied to substrate first (excluding horizontal terminations).

A similar approach to a termination, i.e., back-wrapping, can be taken at a horizontal termination; however, accommodating drainage of the cavity becomes more difficult, as the base coat extends across the bottom of the drainage cavity to the substrate.

Pre-wrapping (ULC S716.2, Clause 10.2.2.5)

Pre-wrapping involves application of reinforcing mesh encapsulated in base coat that is applied to the back and termination edge of the thermal insulation board before it is installed on the substrate. The base coat and reinforcing mesh must extend at least 65 mm (2 ½ in.) onto the back of the thermal insulation board from the wrapped edge. The mesh should initially be left loose at the front and outer edge of the board to allow for rasping. As with back-wrapping, the starter strip of reinforcing mesh must be sufficiently long to allow at least 65 mm (2 ½ in.), or more as specified by the Manufacturer's Written Installation Instructions, to extend onto the face of the thermal insulation board after the board is installed on the substrate.

When pre-wrapping terminations, continuity of the back-wrap at joints between adjacent insulation boards is required. Typically, prior to attachment of the pre-wrapped thermal insulation board, a strip of transition reinforcing mesh is applied to the substrate at the location where the individual thermal insulation boards will meet using a continuous application of adhesive. The strip of transition reinforcing mesh must extend at least 65 mm (2 ½ in.) behind each pre-wrapped thermal insulation board and must be wide enough to overlap each board by at

least 65 mm (2 ½ in.), or more if required by the Manufacturer's published written installation instructions. After the thermal insulation boards are installed, the transition reinforcing mesh is wrapped onto the face of the adjacent boards; the transition reinforcing mesh must be long enough to wrap at least 65 mm (2 ½ in.) onto the face of the thermal insulation boards. Figure 21 depicts the pre-wrapping method.

Alternatively, a minimum of 65 mm (2 ½ in.) of uncoated reinforcing mesh can be left to extend past the end of the thermal insulation board for tie-in to the adjacent thermal insulation board.

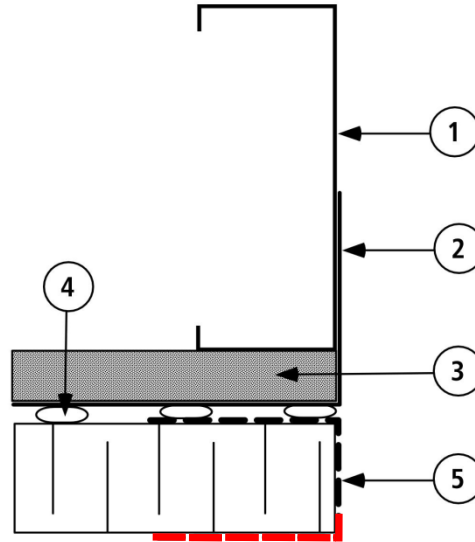

1. STRUCTURAL SUPPORT.
2. LIQUID APPLIED WATER RESISTIVE BARRIER.
3. SUBSTRATE.
4. ADHESIVE ATTACHMENT.
5. BASE COAT AND REINFORCING MESH (mesh should initially be left loose at the front and outer edge of the board to allow for rasping)
6. THERMAL INSULATION BOARD.

Figure 21: Pre-wrapping plan view – mesh applied to insulation first.

Edge-wrapping (ULC S716.2, Clause 10.2.2.4)

After the thermal insulation board is installed, the base coat and reinforcing mesh is installed from the face of the thermal insulation board, over the exposed edges of the thermal insulation board, and onto the edges of the adjacent and independent substrate surface, such as the window return. The base coat and reinforcing mesh must extend at least 65 mm (2 ½ in.) onto the adjacent surface. The edge-wrapping will ultimately be concealed from exposure. Figure 22 depicts the edge-wrapping method.

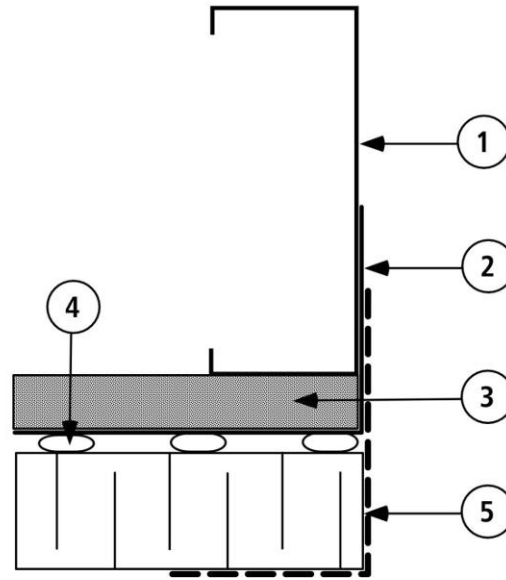

1. STRUCTURAL SUPPORT.
2. LIQUID APPLIED WATER RESISTIVE BARRIER.
3. SUBSTRATE.
4. ADHESIVE ATTACHMENT.
5. BASE COAT AND REINFORCING MESH.
6. THERMAL INSULATION BOARD.

Figure 22: Edge-wrapping plan view – mesh applied to insulation and into opening.

All wrapping methods described above require that the base coat material first be applied to all surfaces to be wrapped and mesh embedded into this material while it is still in a workable state. A second coat is almost always required to achieve complete mesh encapsulation and an appropriate surface for sealant application. The base coat and reinforcing mesh used for terminations must be of a type and weight that is tested and approved by the Manufacturer and in accordance with the Manufacturers published written installation instructions.

When wrapping, the use of termination accessories, such as starter tracks or prefabricated trim pieces is not permitted unless the EIFS manufacturer has demonstrated conformance of such termination accessories with the EIFS Materials Standard.

2.10 EIFS Mouldings

An EIFS moulding is defined by the EIFS standards as “an insulation profile that is mounted on or incorporated into the thermal insulation boards and covered by the EIFS lamina”. This is not to be confused with a prefabricated moulding (hereafter referred to as an Exterior Prefabricated Profile (EPP)) that is applied over the EIFS and not covered with EIFS lamina.

EIFS cladding provides great aesthetic advantages in its ability to incorporate a wide variety of architectural profiles, creating façade depth and facilitating architectural design. The following are some of the architectural profiles, or mouldings, that are available:

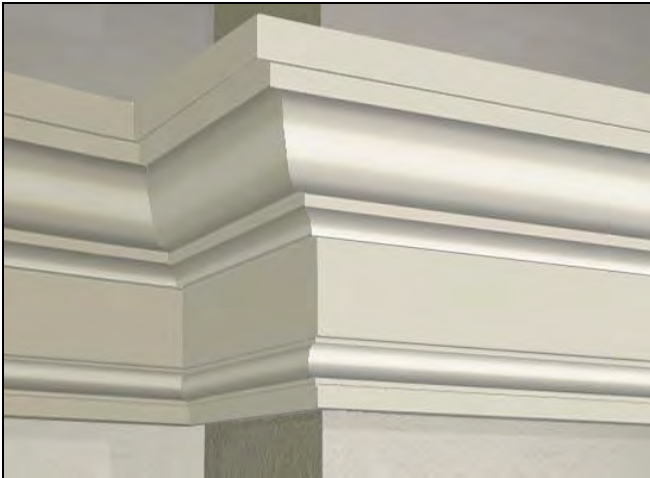

Figure 23: *Bands* - Horizontally placed profiles, often used in the middle of a wall to break up a large, flat area or along the underside of building joints to mask their presence.

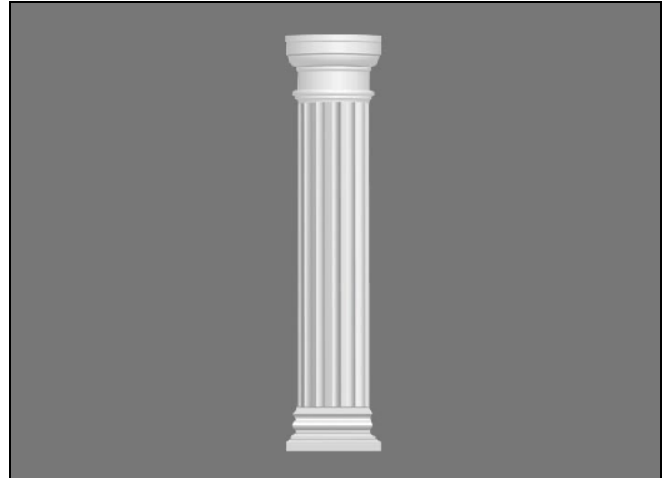

Figure 24: *Columns* - Decorative forms that are non-structural, most often having a cylindrical shaft with a capital and a base. These decorative shapes are produced to fit around structural poles and posts, such as those made of wood or steel, providing the appearance of a smooth or fluted cylinder.

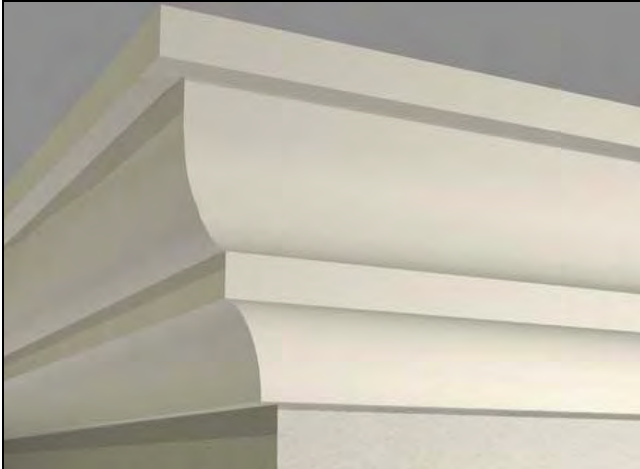

Figure 25: Cornices - Also called crown mouldings, cornices provide a finish at the top of a wall, usually at the intersection of the soffit and the wall. They are often larger at the top than the bottom to provide a tapered look. OR: A continuous horizontal projecting moulding at the top of a wall or building



Figure 26: Headers - Mouldings applied over the top of windows or doors. Headers are often larger and protrude further than trims and may include a drip edge to deflect water.

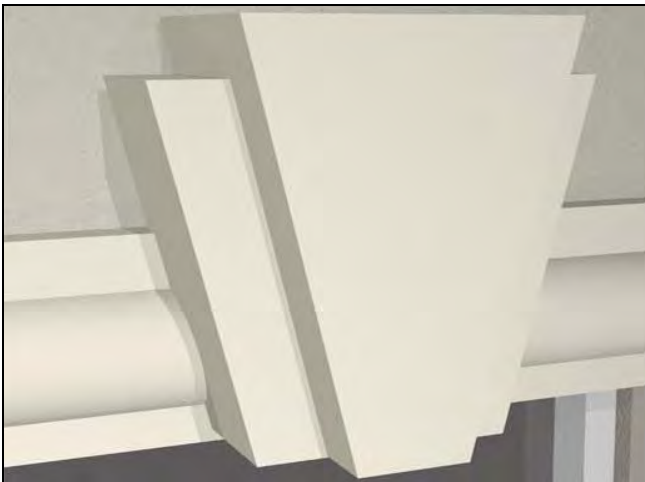

Figure 27: Keystones - The wedge-shaped detail at the summit of an arch, which in the past, structurally held the arch together. Keystones are typically no longer structural, but simply a decorative architectural feature centered over windows or doors.



Figure 28: Pilasters - A shallow rectangular column attached to the face of a wall, designed to look like columns embedded in the wall to provide an illusion of support. Often smooth, they may also be fluted. A pilaster will also typically include a moulded cap and base.

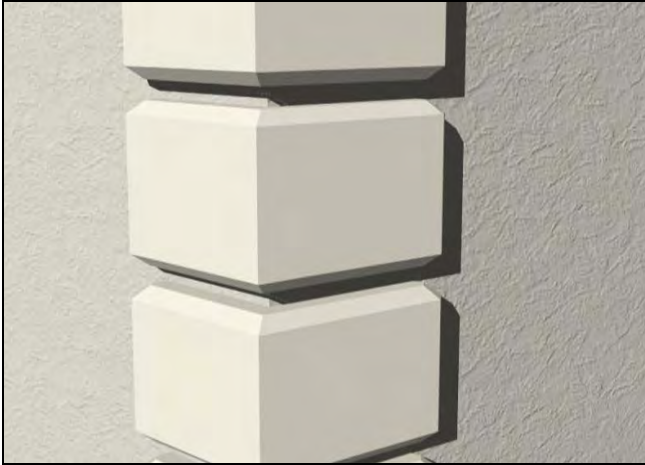

Figure 29: Quoins - Corner detailing forms designed to imitate the large stones used at the corners of masonry buildings to provide a decorative contrast with the adjoining walls.

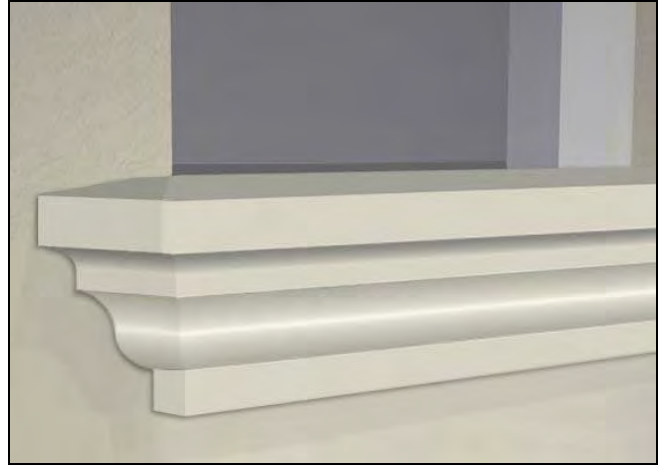

Figure 30: Sills - The horizontal member used at the bottom of windows, which protrudes from the wall to help deflect precipitation from the wall.



Figure 31: Trim - Typically flatter and narrower than headers or sills and used between the header and sill to improve the appearance of the jamb of a door or window. In some cases, trim may be used around the entire perimeter of a window. The term, "trim", may also be used instead of the term, "band". The framing or edging of openings are also known as casing.

Exterior Prefabricated Profiles

In the past, EIFS mouldings were only created in the field by building up layers of EPS insulation that were then incorporated into the base coat and mesh. In the 1990s, exterior prefabricated profiles (EPP) entered the market. Some EPP manufacturers use EIFS manufacturer materials (i.e. base coat and mesh) however; other EPP manufacturers developed their own propriety materials. Such materials are generally not tested to the same standard as EIFS materials. EPP's typically consist of an expanded polystyrene (EPS) core, covered by a polymer-modified cement base coat with integral glass fibre reinforcing mesh. Some materials such as polyurethane resins are not acceptable products for use with EIFS due to poor performance under fire conditions.

While they resemble the appearance of concrete elements, EIFS mouldings are much lighter, making them easier to install than their concrete counterparts.

All highly contoured EPP's are manufactured using a self-adhesive glass fibre reinforcing mesh applied to the surface of the insulation under the application of base coat. The placement and use of self-adhesive mesh is necessary for the extrusion process for highly contoured and ornate profiles. However, this method is not preferred, since the bonding strength of the self-adhesive mesh is less than the bonding strength obtained when mesh is encapsulated in base coat that is bonded to the insulation. Further, there are no standard test requirements to evaluate the bonding strength of self-adhesive mesh or its performance when used as an integral part of the lamina. Self-adhesive mesh is not used for fire tested assemblies and therefore its performance is not known.

Since the EPP is not part of the EIFS manufactured system, separate warranties are issued for the EIFS and EPPs. However, a single system EIFS warranty is provided for EIFS mouldings that are incorporated into the EIFS as defined earlier in this section.

Note: EPPs are not covered by the EIFS standards.

2.10.1 Design Considerations

This section discusses design considerations for EIFS mouldings. The same principals should be applied to EPPs.

Mouldings with too little slope and a textured finish tend to retain water on the surface resulting in softening and re-emulsification of the finish coat. For the same reasons, deterioration can occur due to prolonged exposure to snow and ice. Not following the ULC standard requirements and recommendations in this manual will result in increased maintenance.

The size of the moulding is generally limited by the thickness of the insulation that has been fire tested unless the moulding is over a framed projection. A projecting moulding greater than 300mm (12 in.) in width should be covered with a metal flashing or other durable material.

To prevent water ponding and retention, the top surface of EIFS mouldings that project out from the wall's vertical plane should be sloped to the wall's exterior with a minimum rise over run of 1:2 for drainage (*ULC S716.3, Clause 7.1.5*).

One exception to the requirement for the moulding to be sloped is where the moulding is protected by a metal flashing or other durable material, in which case the slope may be reduced

(ULC S716.3, Clause 7.1.5.A). Some manufacturers produce a specialized waterproof base coat to enhance the moisture resistance of low-slope projections; these specialized base coats should not be confused with standard water-resistant EIFS base coats and elastomeric or high-content polymer finishes. Waterproof base coats are typically low in vapour permeance and, while not recommended for large wall areas, are suitable for the upper surfaces of mouldings and sloped surfaces. However, as a rule, it is preferable that the upper surfaces of mouldings that are often exposed to wind-driven rain, and snow or ice accumulation are counter-flashed with metal, including a drip edge to deflect water run-off away from the face of the wall. The drip edge is important as most horizontal projections tend to accumulate dust and dirt and therefore water flowing from the upper surfaces of the moulding down the face of the wall could cause staining.



Figure 32: Example of metal flashing at EIFS cornice.



Figure 33: Example of metal flashing at EIFS cornice.

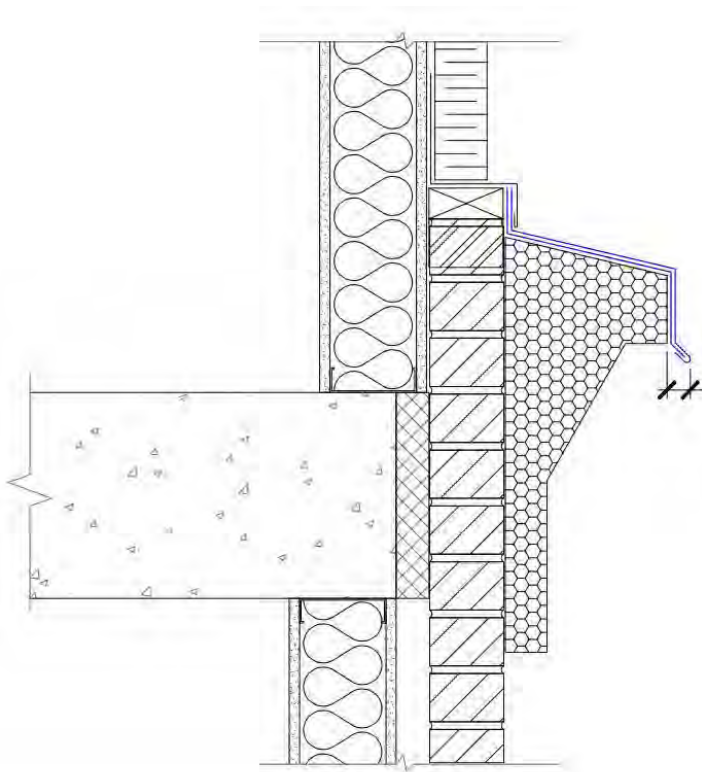

Figure 34: Example of metal flashing with drip edge at EIFS moulding.

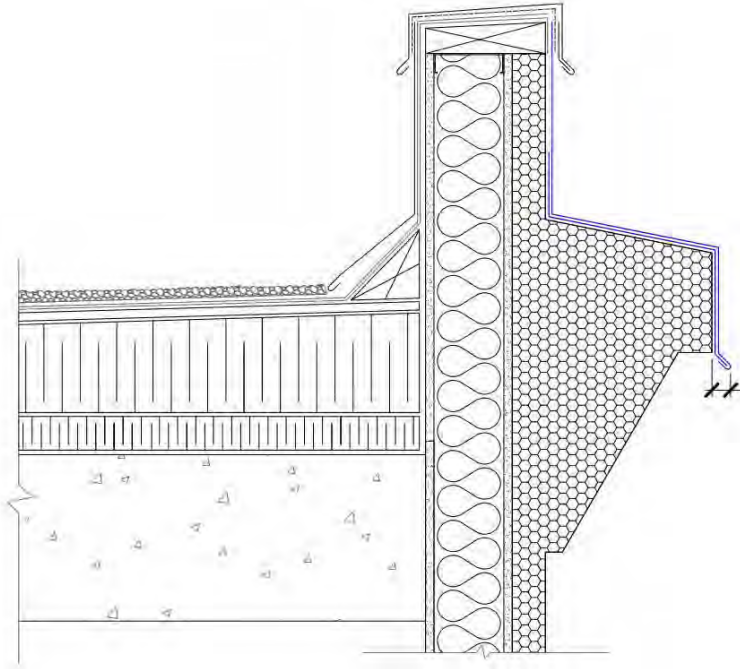

Figure 35: Example of metal flashing at EIFS cornice.

The other exception to the requirement to slope the top surface of EIFS mouldings is where there is an overhang in close proximity above the moulding (*ULC S716.3, Clause 7.1.5.B*). Close proximity is considered to be a vertical distance between the top of the EIFS moulding and the underside of the overhang of not more than one quarter of the horizontal eave overhang. Such an overhang is expected to provide sufficient protection to the moulding to prevent rain or snow accumulation on its surface.

EIFS mouldings can be finished with a number of architectural coatings, typically acrylic-based latex finishes, applied by trowel, spray, or roller. Smooth textures are generally preferred to textured finishes to minimize dirt and mildew accumulation and to help prevent surface water retention. Elastomeric coatings are available that can be applied to the base coat, foregoing the necessity of a textured finish coat and making the exposed surface more smooth. It should be noted, however, that the coatings supplied by an EIFS manufacturer are specifically formulated for application over alkaline cementitious surfaces, such as the EIFS mouldings; alternate coatings or finishes should not be used without the approval of the EIFS manufacturer.

The selection of earth-tone colours for architectural mouldings may also help conceal staining. However, it may still be necessary to clean the finish surfaces on a periodic basis with detergent and soft brushing. A power washer can be used for cleaning, but care must be taken to ensure that water is not driven into the wall assembly and that the finish coat is not damaged; a spray no greater than 1034 kPa (150 psi) from a distance of at least 1.8 m (6 ft.) is recommended.

As the corners of buildings are often more susceptible to damage than other parts of the wall, there is an advantage in using an architectural profile at the building corner. On a monolithic wall, patches are obvious, often necessitating a repair to an entire wall area. Damage to a corner

may mean an entire wall needs refinishing. However, should an architectural profile at the corner of the wall be damaged, only the profile needs repair or replacement, minimizing the cost of the repair.

It may be necessary to provide shop drawings for architectural mouldings. The shop drawings should incorporate the measured profiles and acceptable tolerances for the plumb and plane of the wall assembly. The shop drawings should also detail any supplementary support systems needed for the installation of the mouldings. Shop drawings should be provided for any profile that is fabricated off-site.

2.10.2 Installation

At present, a standard approach for the installation of EIFS mouldings has not been developed. In some cases, the EPS of the EIFS moulding is adhered directly to the thermal insulation or substrate, and the moulding incorporated into the base coat and mesh of the wall system. In other cases, the base coat and mesh will be applied to the thermal insulation first, and the moulding will be adhered to the dry base coat; this approach is generally preferred for fire safety reasons. For both methods, the upper horizontal gap between the moulding shape and the wall must be treated as per standard installation practice (e.g. with slivers of insulation or spray) foam to minimize the potential for cracking. It is also recommended that a reinforcing mesh overlap be provided across the gap (see Figure 36).

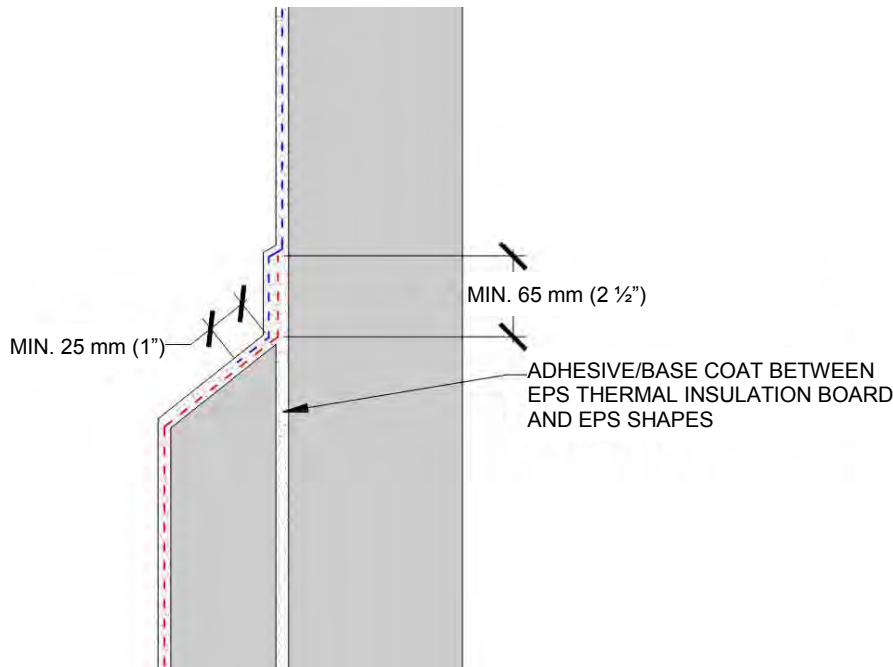

Figure 36: Mesh overlap at moulding.

Where larger mouldings are employed, additional supplementary support (in addition to adhesive) may be required; such support can take the form of keyed wood blocking within the foam core and/or the use of temporary or permanent mechanical fasteners. EIFS mouldings at parapets require the installation of structural blocking at the top exposed horizontal surface to provide support for the installation of flashing (*ULC S716.3, Clause 12.1.6*).

Once the moulding is firmly attached to the wall, it should be encapsulated in a layer of base coat and mesh that integrates with the base coat and mesh of the wall system.

Some exterior prefabricated profiles are manufactured with extra mesh that extends either side of the profile to integrate with the wall. The mesh overlap should be at least 65 mm (2 ½ in.), or longer if recommended by the manufacturer. Since warranties for EIFS and prefabricated mouldings are separate, the moulding profiles should be applied over the completed EIFS reinforced base coat prior to completing the mesh overlap. While some moulding manufacturers expect their products to perform without this integration into the mesh and base coat of the wall system, it is not a recommended approach. Care must be taken that the materials used to manufacture the moulding are compatible with the materials in the wall system. In all cases, the EIFS manufacturer should be consulted regarding the integration of exterior prefabricated profiles with the EIFS.

Consideration must also be given to joints in the EIFS mouldings. If EIFS trim needs to be joined, typically a flexible, durable adhesive must be used to join the profiles, as well as some type of joint reinforcement (e.g., fibre mesh in adhesive mix).

Expansion joints must be installed in the EIFS mouldings where they exist in the substrate, and where they adjoin dissimilar construction. Larger mouldings require more frequent expansion and control joints, and may require expansion at more regular intervals than within the main EIFS cladding.

The chief concern about EIFS mouldings with respect to fire safety is the EPS core, since it is a foam plastic insulation. At expansion joints, the ends of each exposed surface of the architectural profile must be properly back-wrapped. All cut ends, whether the profile is created in the field or pre-manufactured, must be wrapped and the mesh must be fully encapsulated in base coat. Further, similar to pre-wrapped systems, a strip of transition reinforcing mesh is required at joints.

EIFS mouldings have limited strength; care must be taken whenever maintenance is being performed on a building that workers do not step on horizontal mouldings. EIFS mouldings should never be used as steps. At parapets, to provide some additional strength, mouldings at top exposed horizontal surfaces should be supported by wood blocking (See Illustration 18-25).

3. CLADDING DESIGN USING EIFS

3.1 Fire Safety

The type of EIFS that can be used on a building depends on a variety of factors relating to the building as well as its proximity to neighbouring property boundaries. Most EIFS incorporate combustible foam plastic insulation and other combustible components and are governed accordingly through the allowances of the code that permit the use of combustible components.

Much of the National Building Code deals with the issue of fire safety in buildings. Some buildings are required by Code to be of noncombustible construction, depending on their group and occupancy classification, their height, their building area, and whether or not the building is sprinklered. A complete discussion of which buildings are required to be of noncombustible construction is beyond the scope of this Practice Manual. Readers are referred to their applicable Building Code for their jurisdiction and to the Principal Authority for their area for this information.

Once the requirement for combustible or noncombustible construction is known, as well as any other limitations, it is then possible to determine what EIFS can be used. The fire safety requirements in the 2010 National Building Code of Canada are discussed in this document. However, fire safety requirements in Provincial and local Building Codes can differ from the National Building Code of Canada. Also, Building Code requirements may be interpreted differently in different jurisdictions. Therefore, it is extremely important that, where the building is required to be of noncombustible construction, and combustible component are to be employed, compliance with the building code interpretations of principal authorities should be confirmed (*ULC S716.3, Clause 6.1.1*). While EIFS finishes are typically combustible, the finish is considered a minor combustible component and is generally not restricted by the Building Code.

3.1.1 Buildings Allowed to be of Combustible Construction

Buildings that are allowed to be of combustible construction impose the fewest restrictions on the use of EIFS, allowing EIFS with either foam plastic or non-foam plastic insulation to be used and its thickness is not governed by the limitations of maximum tested thicknesses that would otherwise apply. However, limitations related to spatial separations may still apply and although your building may be permitted to be of combustible construction, the cladding may be required to be noncombustible, or satisfy the criteria set out in the applicable Sentences that allow for the use of combustible components (namely, foam plastic insulation) in noncombustible construction.

3.1.2 Buildings Required to be of Noncombustible Construction

Most EIFS incorporate combustible foam plastic insulation and/or combustible components. As already noted, this does not ban EIFS use in buildings required to be of noncombustible construction. However, Building Codes do place limitations on the use of EIFS employing combustible insulation in buildings required to be of noncombustible construction. As such, EIFS proponents must be able to demonstrate compliance to the provisions that allow for their use.

Any combustible insulation used in non-combustible construction must not have a flame spread rating greater than 500 when tested to CAN/ULC-S102.2, “Standard Method of Test for Surface Burning Characteristics of Flooring, Floor Coverings, and Miscellaneous Materials and Assemblies” [NBC 2010, Article 3.1.5.12.]. Within this Article, we also read that foam plastic insulations must be separated from the interior space by one of the listed thermal barriers, or tested to CAN/ULC-S124 and meet the code noted criteria for thermal barrier properties.

In addition to these requirements (related to insulation), the EIFS assembly must meet the test requirements specified in the Building Code as found in Article 3.1.5.5. It is often believed that this Article and the cited test standard within it, was developed to accommodate EIFS use in noncombustible construction; this belief is incorrect. The test requirements noted in this Article apply to all assemblies containing combustible components if destined to be used in noncombustible construction.

NOTE: Since the fire testing of cladding systems is specified in building codes, the EIFS standards do not include fire-testing requirements; this is to avoid the possibility of conflicts developing between the EIFS standards and building codes.

Mineral Fibre Insulation/ Noncombustible Base Coat

EIFS that employ mineral fibre insulation, rather than foam plastic insulation, and a non-combustible base coat are considered to be noncombustible and can be used without fire related restrictions in any building required to be of noncombustible construction. The mineral fibre insulation is required to be of an appropriate density and must meet either the code adopted requirements to be classified as a noncombustible material, or conform to Article 3.1.5.1. The same requirement extends to the base coat, but does not extend to the finish as it is not a cladding, but a minor combustible component, not unlike paint.

Foam Plastic Insulation

Provided that the limiting distances and the corresponding allowable unprotected openings is greater than 10%, EIFS with foam plastic insulation can be used on a building required to be of noncombustible construction.

There are two Articles within the National Building Code of Canada that accommodate the use of EIFS with foam plastic insulation.

The first, which having been satisfied, generally waives any additional requirements, is Article 3.1.5.5. Within this Article the code requires assemblies containing combustible components to demonstrate conformance to the noted pass/fail criteria when tested in accordance to CAN/ULC-S134. In a number of jurisdictions, satisfaction of this Article is considered mandatory and cannot be waived by satisfaction of other test requirements related to the protection of foam plastic insulation. In limited jurisdictions, namely Ontario, satisfaction of Article 3.2.3.8., waives this [S134] test requirement and other limitations found within OBC Article 3.1.5.5. The National Building Code does not contain any such allowance.

The second Article that provides methods to accommodate foam plastic insulation is Article 3.2.3.8. This Article sets out conditions of acceptance for foam plastic’s use where noncombustible cladding is required. As noted in the opening paragraph, this Article may apply regardless of the allowable construction. Article 3.2.3.8. sets out the pass/fail criteria and

conditions for acceptance for the protection of foam plastic when tested in accordance to CAN/ULC-S101, “Standard Methods of Fire Endurance Tests of Building Construction and Materials”, of a sample wall at least 9.3 m² (100 sq.ft.) in area and with no dimension less than 2.75 m is required to demonstrate that the base coat (protective layer) will remain in place for at least 15 minutes when exposed to fire and that no through openings will develop that are visible when viewed normal to the face of the material [NBC 2010, Article 3.2.3.8]. This test is conducted to ensure that the base coat will remain in place to protect the insulation.

The base coat must also meet the requirements of CAN/ULC-S114, “Standard Method of Test for Determination of Non-Combustibility in Building Materials”, to be considered noncombustible [NBC 2005, Sentence 1.4.1.2.(1)], or Article 3.1.5.1. Responsible authorities such as the designer of record, need to determine if this allowance is available based on which Sentence of Article 3.2.3.7. is applicable as determined by spatial limitations and allowable unprotected openings. Where allowable unprotected opening are less than 10%, mineral wool is needed and S101 testing applicable to the protection of foam plastic is no longer required. That said, where allowable unprotected openings are greater than 10%, systems meeting the requirements of Article 3.1.5.5. generally waive additional test requirements set out in Article 3.2.3.8. EIFS not meeting the requirements of Article 3.1.5.5. may be permitted in combustible construction, however, depending on building group and division classification, number of stories, presence or absence of sprinklers, limiting distance and allowable unprotected openings, satisfaction of Article 3.2.3.8. may still be required.

Designers should always bear in mind that Provincial Building Code fire safety requirements can differ from the National Building Code of Canada (upon which the above discussions are based). Further, building officials may apply and interpret Building Code requirements in different ways. Therefore, regardless of the requirements stated in this Practice Manual, the designer remains responsible for verifying the appropriateness of any EIFS system with the Principal Authority.

CAUTION!

It is recommended that code restrictions be understood and accommodated prior to finalizing design. Designers wishing to further explore fire safety of a specific product should consult with the EIFS manufacturer.

3.1.3 Limitations on Insulation Thickness

Where a fire-tested, combustible insulation is employed, the components and conditions of acceptance cannot be changed from those incorporated in the fire listing provided by the EIFS manufacturer. This means that when using systems required to meet Building Code fire safety requirements, the insulation may not exceed the maximum tested thickness, including any mouldings, such as cornices, trims, etc. As the maximum thickness of insulation tested will vary among manufacturers, the manufacturer forming your base design should be consulted to identify the tested limits for a particular system.

3.1.4 Protecting Interior Space from Foamed Plastic Insulation

The Building Code requires that foam plastic insulation must be protected on the interior side by a thermal barrier to limit and delay its potential contribution to a fire. The thermal barrier, when tested in conformance with CAN/ULC-S124 “Fire Endurance Tests of Building Construction and Materials”, must not develop an average temperature rise more than 140 °C or a maximum temperature rise more than 180 °C at any point on its unexposed face within 10 minutes; gypsum

board that is at least 12.7 mm ($\frac{1}{2}$ in.) thick that is mechanically fastened to a supporting assembly independent of the insulation and with all joints either backed or taped and filled will meet this requirement. If the building is sprinklered throughout and not more than 18 m high, the thermal barrier need only meet the requirements of Classification B when tested in conformance with CAN/ULC-S124, “Test for the Evaluation of Protective Coverings for Foamed Plastic”. Untaped gypsum board at least 12.7 mm ($\frac{1}{2}$ in.) thick mechanically fastened to a supporting assembly independent of the insulation meets this requirement [NBC 2010, Sentence 3.1.5.12.(3)]. Since EIFS are typically installed on wall systems that incorporate 12.7 mm ($\frac{1}{2}$ inch) gypsum, masonry, and/or concrete, this requirement is easily satisfied.

3.2 Resistance to Rainwater Penetration

3.2.1 History

As mentioned at the start of this Practice Manual, the CMHC EIFS Best Practice Guide published in 2004 was used as a starting point for this Manual. However, in the short period of time between then and publication of this Manual, the EIFS industry as a whole has been very proactive, resulting in great strides being made in EIFS technology and application. What was termed “best practice” in 2004 is now standard practice. This is particularly true with respect to rain penetration control. The evolution from “face-sealed” systems that incorporated no secondary water resistive barrier or drainage capability to “dual barrier” systems that included a secondary barrier but without intentional drainage are a technology no longer employed.

Properly applied and maintained, EIFS lamina, or more specifically the base coat remains for all practical purposes impermeable to rainwater penetration. Even small cracks or punctures in an EIFS lamina tend to not allow significant moisture ingress.

The greatest risk for water ingress in any EIF system is at joints between EIFS panels, interfaces between the EIFS and other wall elements, and at penetrations through the EIFS, such as windows or doors. In addition, other building envelope elements, such as windows, doors and roofs, may develop problems resulting in water penetration that could drain into or behind the EIFS. Like any wall cladding assembly, maintaining joint seals and transition details to adjacent building components over the life of the building is a necessary practice to mitigate the risk of potential deterioration and obtain the greatest service life of the cladding/wall assembly. The risk of deterioration has been greatly reduced due to the movement away from “face-sealed” and “dual-barrier” systems to “dual barrier systems with drainage” as discussed below.

3.2.2 Current Practice

Model building code requirements generally state that the building assembly must be designed and constructed to minimize ingress of precipitation into the building assembly or its components and to prevent ingress of precipitation into the interior space. Good design practice generally dictates that all areas of the building envelope have a primary and a secondary line of defense against water penetration. Therefore, current practice dictates that as a minimum, EIFS walls should be designed with:

1. The EIFS providing a primary defense against water penetration.
2. A continuous secondary water resistive barrier (WRB) system behind the EIFS prevents water that penetrates past the EIFS from reaching the water sensitive substrates or the building interior. The WRB system is discussed in detail in Section 2.2 and 3.4;
3. A drained cavity continuous between moisture egress locations. Drainage of EIFS was discussed in detail in Section 2.2.11.
4. Flashing to divert water that may penetrate these locations and drain it to the exterior.

A wall assembly also requires a continuous air barrier control layer. For most EIF systems, the secondary water resistive barrier is also the air barrier. This is also the ideal location for the air barrier in terms of rainwater penetration control since the air barrier allows the primary and secondary barriers to work effectively according to the rainscreen principle.

The EIFS lamina (or more specifically, the base coat) is the primary line of defense and the WRB is the secondary line of defense. The lamina minimizes the ingress of water into the EIFS assembly while the WRB, drainage cavity and diverter flashings ensure water does not reach the substrate or building interior. The WRB system must be continuous and made continuous to the water resistive barrier component of other building elements such as windows, doors and other claddings (*ULC S716.3, Clause 7.1.4*).

An important consideration in the design to prevent rain penetration is that the drainage cavity is intended only for removal of water that inadvertently bypasses the lamina; it is not intended to provide drainage for other building elements, such as windows, doors, or adjacent claddings. The EIFS Design Standard specifically states that, “EIFS cladding shall be designed to minimize water penetration into the drainage cavity” (*ULC S716.3, Clause 7.1.1*) and that, “Windows, doors, and claddings adjacent to the EIFS shall be designed to minimize water that penetrates the windows, doors and adjacent claddings from draining behind the EIFS” (*ULC S716.3, Clause 7.1.3*). This means that all these elements must be independently flashed to the building exterior.

In other words, windows, doors, and adjacent claddings and building assemblies must have their own secondary line of defence against water penetration that directs water to the exterior of the building, NOT into the EIFS drainage cavity.

CAUTION!

This means that, for example, leakage through a window must be addressed with a flashing to the exterior. The assumption cannot be made in the cladding design that window leakage will be addressed by the WRB.

Interfaces between dissimilar cladding materials require particular attention to ensure this continuity is maintained. Careful detailing is necessary at the design stage to assure that weather and air seals, and drainage are achieved at these locations. Although shop drawings are not required for field installations, as a minimum, design drawings, details and specifications shall include details of interfaces and joints, including flashings required to maintain continuity of the primary (lamina) and secondary water resistive barrier system and of air and vapour barriers at the following building locations as a minimum (*ULC S716.3, Clause 5.1.1*):

- Foundation walls;
- Window and door sills;
- Window and door heads;
- Window and door jambs;
- Adjacent dissimilar cladding systems;
- Building envelope penetrations, such as exhaust boxes, signs, guard anchors or mechanical equipment;
- At joints intended to drain water;
- At intersecting balustrades;
- Roof-to-wall interfaces;
- Above roofing (penthouses and return walls);
- Roof parapets and overhangs; and

- Balconies.

Details are to show any membranes, flashings, important sealant laps, fasteners or hems in flashings. It may be necessary to distort the scale somewhat to allow for this level of illustration. Requirement for details is not unique to EIFS. NBC Division C, 2.2.5.2, requires that the drawings show sufficient details to demonstrate compliance with the Code.

It is also recommended that water testing of a mock-up be conducted for large projects. Water testing at window/door interfaces with the EIFS should be completed to check that the as-built construction will provide an adequately water-resistant assembly. The testing should involve applying, as a minimum, the window design pressure across the cladding assembly. This should be completed prior to the installation of interior finishes or stud space insulation to allow checking for ingress into the wall cavity.

3.2.3 Pressure Moderated EIFS

Pressure moderation is complex and is not covered in detail in this manual. If considering its use, the EIFS manufacturer should be consulted for availability and approach. Other resources include NRC-IRC Construction Technology Updates 17 and 34.

Pressure moderation is intended to minimize the wind driven pressures that can force water through cracks and defects into a cladding assembly.

Some manufactured EIF systems incorporate details that provide some marginal improvements in rainwater penetration resistance by creating “pressure moderation” across the EIFS surface, and through the drainage cavity (or air space) to the air barrier (which is typically the WRB as well). Detailing requires i) that the air barrier be fully supported and unable to move, ii) that the wall area be compartmentalized and, iii) that the drainage cavity has sufficient venting. For pressure moderation to work at all, the pressure needs to be uniform across the EIFS assembly at each compartment. Due to the dynamic nature of wind, uniform pressures are very difficult to achieve constantly and research has demonstrated that only marginal improvements can be obtained by pressure moderation. If considering the use of pressure moderated systems at all, they should only be contemplated for high-rise or exposed buildings where wind pressure would be more constant. Due to the turbulent winds acting on low-rise buildings and buildings with surrounding structures, the effectiveness of a pressure moderated system is greatly reduced and therefore unnecessary.

3.2.4 Overhangs

In the past, designers incorporated cornices and overhangs to shelter the uppermost and most exposed portions of walls from rain. Window heads and sills were designed with dams and drips to direct water away from window and wall surfaces. Walls were much thicker, preventing or slowing the ingress of rain by absorption. When water did succeed in entering any of the wall components and/or simply soaking the exterior surface of the wall, the lack of airtightness, thermal insulation and vapour permeance of the wall system allowed for effective drying; wall damage from water generally only occurs when walls cannot dry and so stay wet for an extended period of time.

In recent times, competitive market pressures and more stringent regulatory requirements have combined to reduce the drying potential of most wall systems and to eliminate many of the

architectural features which formerly served to shield exposed parts of the window and walls from water. However, the potential for the use of architectural features on an EIFS wall, such as prefabricated trims, cornices, etc., may reduce the wetting on a wall, thus lessening the potential for rain penetration. Roof overhangs of about 300 mm (1 ft.) to 600 mm (2 ft.) can reduce rainwater exposure on low-rise buildings (one to three storeys in height). Increasing the building height augments the exposure to rain as the ability for overhangs to effectively provide shelter decreases with their height above the wall. Higher buildings are also exposed to higher wind speeds. That said, the use of projecting mouldings throughout a building height may help reduce rain exposure.

An overhang that provides shelter from rain can dramatically reduce the frequency and amount of cladding wetting. Roof overhangs can reduce moisture loads on the surface of buildings, thereby improving the long-term durability of cladding systems. The EIFS Design Standard recognizes the protection overhangs can provide. In most cases, the EIFS Design Standard requires any non-vertical EIFS surfaces (such as a horizontal moulding) to be protected with sheet metal or other durable flashing or to be sloped at least 1:2 (50%) (*ULC S716.3, Clause 7.1.5*). However, where there is an overhang in close proximity above the moulding, the protection and slope can be omitted. “Close proximity” is considered to be when the vertical distance between the top of the moulding and the underside of the overhang is not more than one quarter of the horizontal overhang (*ULC S716.3, Clause 7.1.5.B*).

The use of architectural features on a building may reduce the wetting of a wall, but they may also increase moisture loads in specific locations by collecting rainwater and/or snow/ice. The same requirements apply to these features as noted above.

Manufacturers may recommend even steeper slopes or additional protection for their products, as the amount of texture will affect the ability of a surface to drain (*ULC S716.3, Clause 7.1.7*).

3.3 Expansion Joints

Expansion joints are typically the only joint type used with EIFS. Reveals are not considered joints. Control or construction joints are not used.

An expansion joint is a structural separation between building elements that allows independent movement without damage to the assembly. Expansion and contraction of the structure will transfer through to the substrate and therefore to the EIFS. Expansion joints must be carried through the EIFS to accommodate expansion and contraction of building materials due to thermal changes, moisture, wind, gravity, vibration and seismic activity (*ULC S716.3, Clause 13.1.1*).

Expansion joints are required in the EIFS:

1. At expansion joints that occur in the structure or substrate (*ULC S716.3, Clause 13.1.1.A*);
2. Where the substrate or structure changes, i.e., where two dissimilar substrates are located adjacent to one another or a penetration such as a window (*ULC S716.3, Clause 13.1.1.B*);
3. Where significant structural movement may occur due to deflection and shrinkage of the structure, such as concrete creep or wood shrinkage at joists, beams, or suspended floors, and where support conditions change, such as where panels return onto terraces, penthouses or balconies (*ULC S716.3, Clause 13.1.1.C*);
4. Where deflections that might be in excess of L/240 are expected (*ULC S716.3, Clause 13.1.1.D*); and,
5. At the floor line in wood frame construction (except possibly when using engineered wood beams, depending on the expected shrinkage of the beam), or where vertical shrinkage is expected to occur based on the construction of the wall (*ULC S716.3, Clause 13.1.1.E*).

Expansion joints must be aligned with the movement locations in the structure and substrate, and must be wide enough to accommodate the expected movements without stress, deformation or binding of the EIFS (*ULC S716.3, Clause 13.1.4*). A minimum clearance of 20 mm should be provided for expansion joints that are to receive sealants (*ULC S716.3, Clause 13.1.2*).

The EIFS lamina itself will also experience expansion and contraction with changes in temperature. The linear thermal coefficient of expansion for complete EIFS panels varies depending on the product. Laboratory testing has determined that the coefficient typically ranges between 0.008 to 0.015 mm/°C/m. This means that for every 1°C (34°F) change in temperature, a metre long panel will shrink or elongate up to 0.015 mm. If a temperature change of 50°C is considered, as might reasonably be expected between the winter and the summer with the sun beating down on the wall, a nominal two metre EIFS panel could expand by 1.5 mm ($\frac{1}{16}$ in.).

An aesthetic reveal in the EIFS is not considered to be an expansion joint (*ULC S716.3, Clause 13.1.5*).

3.3.1 Expansion Joint Sealant

Expansion joints are typically filled with joint sealant. The selection of an appropriate joint sealant is a very important consideration in the design and construction of an EIFS. The following standards shall be used for the design of joint sealants for EIFS.

1. **Sealant Selection:** ASTM C 1382-05, Test Method for Determining Tensile Adhesion Properties of Sealants When Used in Exterior Insulation and Finish Systems (EIFS) Joints (*ULC S716.3, Clause 13.1.6*).
2. **Joint Design:** ASTM C1472 - 10 Standard Guide for Calculating Movement and Other Effects When Establishing Sealant Joint Width.
3. **Application:** ASTM C1193 - Standard Guide for Use of Joint Sealants and ASTM C1481 Standard Guide for Use of Joint Sealants with Exterior Insulation and Finish Systems (EIFS)

3.3.2 Sealant Compatibility, Adhesion and Sealant Primers

The sealant specified must be compatible with all surfaces to which it needs to bond. A bond between the EIFS and sealant is necessary to achieve adequate adhesion, which means that the sealant and EIFS chemistries must be compatible. As sealant and EIFS chemistries vary, acceptable adhesion cannot be assumed for a specific sealant or class of sealant material. Surface primers are also often required to promote acceptable sealant adhesion. For example, in high humidity applications, primers are typically required to prevent surface moisture from interfering with the sealant adhesion. Therefore, the EIFS and sealant manufacturer should always be consulted to determine the appropriate sealants for use with their system and for conditions where the use of primers is recommended.

If necessary, the sealant adhesion can be qualitatively verified by a trial application of the actual lamina, sealant primer and sealant materials delivered to the site. Testing adhesion to ASTM C1382-05, "Test Method for Determining Tensile Adhesion Properties of Sealants When Used in Exterior Insulation and Finish Systems (EIFS) Joints", provides an important check of the actual chemical and mechanical adhesion achieved. Periodic adhesion tests should also be conducted over the course of the work to check that subsequent batch lots of materials do not result in a change in performance.

The EIFS finish coat shall not be applied onto surfaces that are to receive sealant (*ULC S716.2, Clause 11.2.7*). EIFS sealants are to be applied to the base coat (usually primed) and not to the finish coat, for a number of reasons:

CAUTION!

- The bond strength of the base coat to the insulation is stronger than the bond strength of the finish coat to the base coat.
- In some instances, additives in the finish intended to avoid water absorption or dirt pick-up make it difficult to obtain a good bond between the sealant and the finish.
- When sealant is applied to a textured finish coat, the sealant does not always fill all the recesses of the finish (especially when not properly tooled) allowing water to penetrate and soften or re-emulsify the finish over time which weakens the sealant bond.

As an alternative, a coloured primer can be used prior to sealant application so that the finish coat does not necessarily need to be terminated tight to the sealant to cover the base coat colour. The sealant manufacturer should be contacted prior to undertaking this approach.

A joint sealant problem particular to EIFS walls is that the bond of the sealant to the base coat can be greater than the adhesive strength of the base coat to the insulation. If the joint sealant is not sufficiently flexible (i.e., if its modulus of elasticity is too high), as the EIFS panels contract with cold temperatures and the joint wide increases, the stress created could exceed the strength of the EIFS; rather than the sealant stretching to accommodate the movement, the base coat could fail or pull away from the insulation creating a crack that can allow water penetration into the wall.

Therefore, sealants with a low modulus of elasticity are generally recommended for use with EIFS walls.

CAUTION!

Although the ASTM C1382 document does not provide pass/fail criteria, it does provide useful information with regards to sealant load at varying degrees of elongation and under a variety of environmental conditions. It is recommended that test results should not exceed 100 kPa (15 psi) at 25% sealant elongation, and no sealant failure, whether it is adhesive or cohesive in nature, should occur up to 50% elongation. The test results can be interpreted for the particular application being considered, and it is then incumbent upon the designer, manufacturer and/or contractor to interpret the test results and design the sealant joints appropriately.

In addition, for EIFS with thin lamina, base coat thickening and/or special reinforcing should be considered at joints. If sealants are improperly applied or if movements are greater than anticipated, thin lamina can be torn and require repair. In addition, removal of sealant when renewal becomes necessary in the future can result in damage to thin lamina. To reduce these risks and promote the ability to maintain seals, the lamina should be specified to have adequate strength at joints. For thin lamina, this may mean lamina thickening and/or special reinforcing.

3.3.3 Sealant Installation

The ASTM standards for sealant application shall be followed as noted above. Most of the requirements for proper sealant installation for other claddings also apply to EIFS.

Specific to EIFS, the EIFS Design and Installation Standards require that minimum clearances for joints are provided, as follows:

- 13 mm ($\frac{1}{2}$ in.) around openings or penetrations that are to receive sealants (*ULC S716.2, Clause 9.2.2.2, and ULC S716.3, Clause 12.1.4*);
- 20 mm ($\frac{3}{4}$ in.) for expansion joints that are to receive sealants (*ULC S716.2, Clause 9.2.2.3, and ULC S716.3, Clause 13.1.2*); and,
- 50 mm (2 in.) around heat emitting devices or exhausts (*ULC S716.2, Clause 9.2.2.4*).

Accepted industry practice is to provide joint widths no less than four times the anticipated movement, limiting strain to 25 percent.

In all cases, specification of the sealant joint profile should follow the sealant manufacturer's recommendations, which may vary from the above recommendations.

3.3.4 Two-Stage Sealant Joints

Two-stage sealant joints are typically used for panelized EIFS or where thick insulation is used (e.g., 100 to 125mm thick) as part of the 'rainscreen' strategy.

Two-stage joints incorporate a drainage space between two seals within the joint (see Figure 37 and 38). An outer bead directly exposed to water and sun and an inner bead (air barrier) that is protected from direct exposure to water and sun. The outer bead contains intentional drainage openings. The inner bead must be tooled to extend and flash water within the joint to drain holes provided in the exterior seal (see Figure 38). Joints should be directed and drained to the exterior at a frequency of about every 3 m to 6 m (9 ft. 10 in. to 19 ft. 8 in.) vertically, and every 3 m (9 ft. 10 in.) horizontally. Drainage openings should have a minimum dimension of 25 mm (1 in.) to allow water to escape.

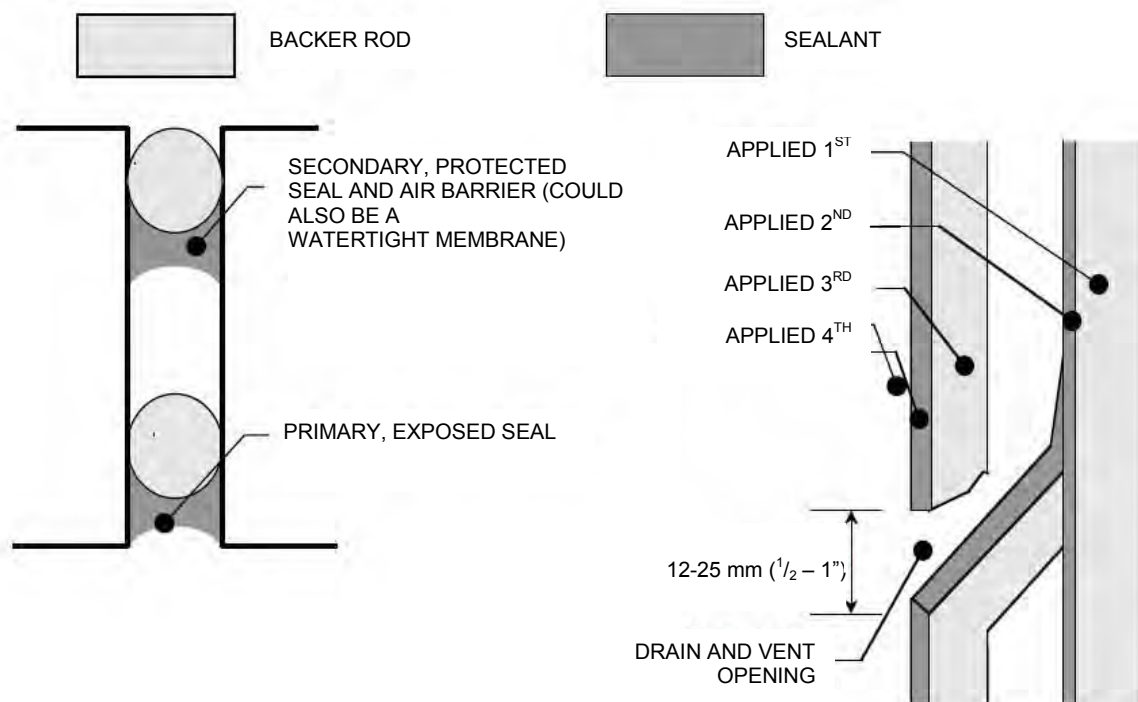

Figure 37: Proper sealant design for two-stage joints.

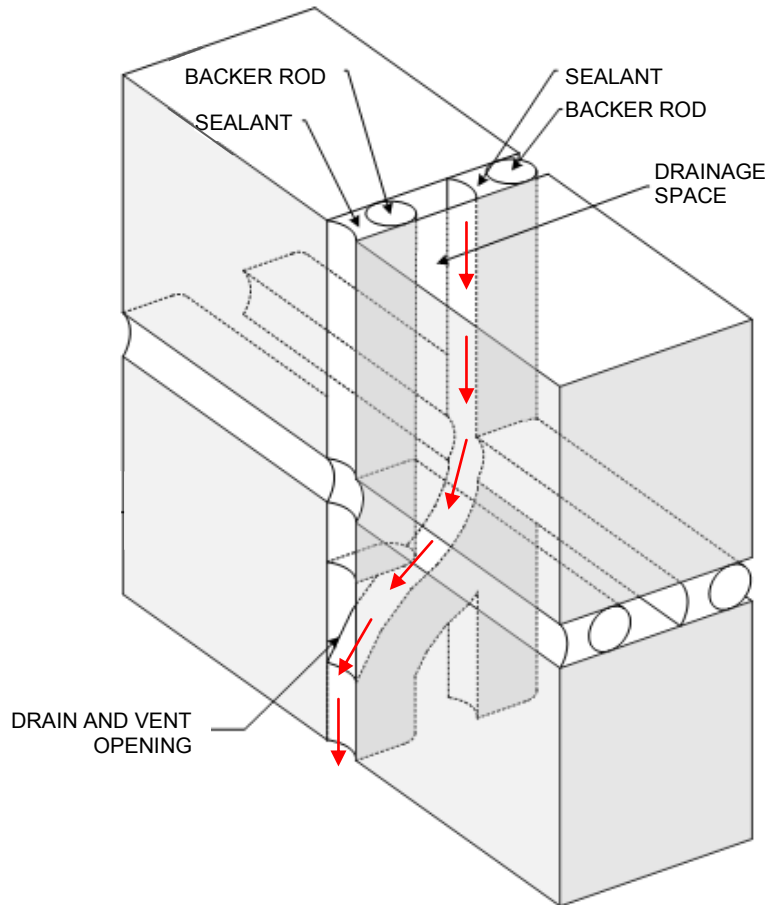

Figure 38: Proper sealant design for two-stage joints (Isometric View).

3.3.5 Two-Stage Joints – Sealant and WRB System Method

For non-panelized EIFS, vertical joint drainage as part of the ‘rainscreen’ strategy can be achieved by connecting the outer sealant bead to the WRB system (see Figure 39). Depending on the location of the joint, the sealant may be connected to the LA-WRB or transition membrane.

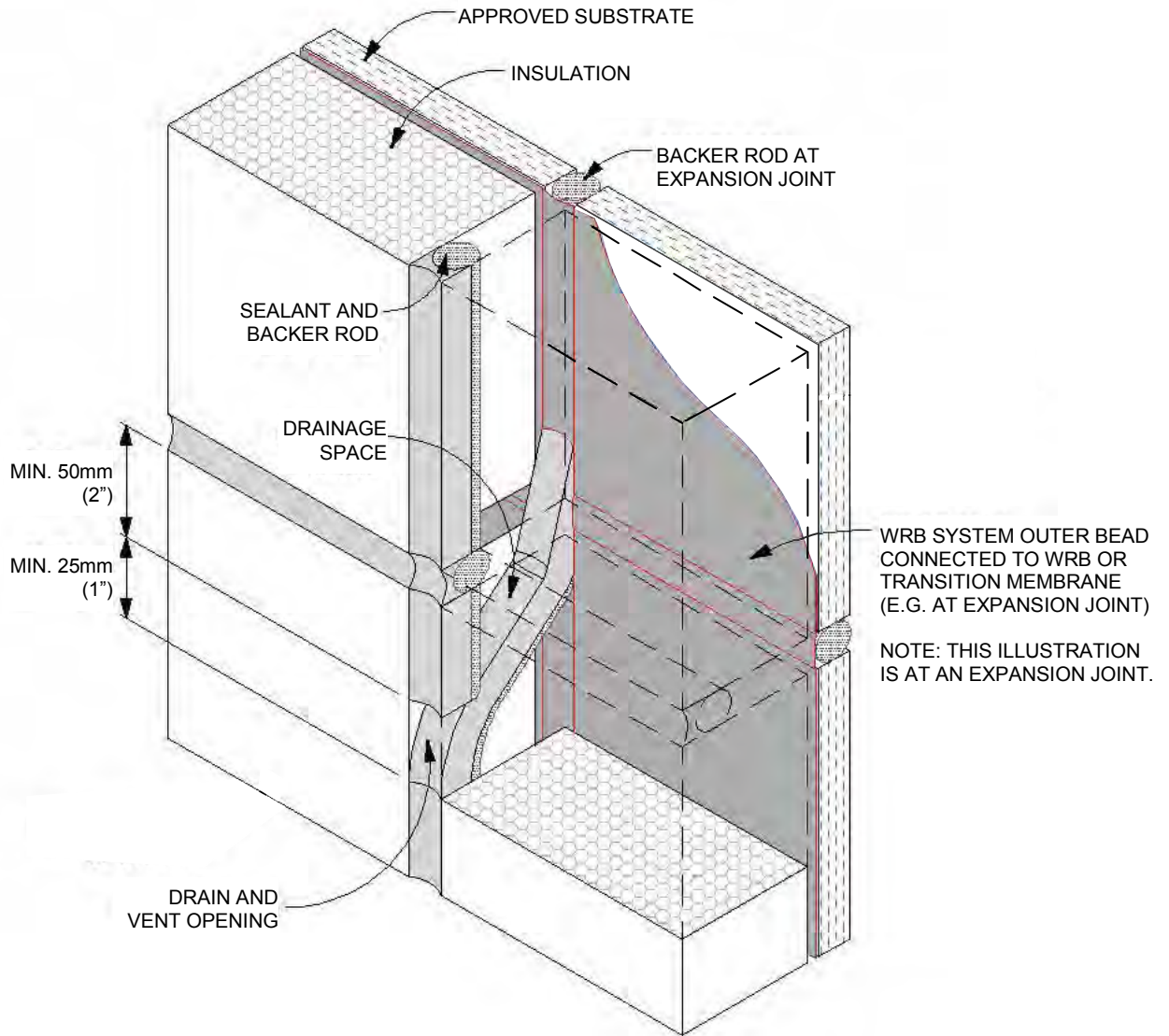

Figure 39: Example of Two-Stage Joint – Sealant and WRB System Method.

WRB System - Transition Flashings

A water resistive barrier (WRB) system flashing is a material possessing low water absorption properties that are applied over substrates susceptible to water absorption to create a continuous surface that prevents water penetration into the wall assembly. The liquid applied water resistive barrier (LA-WRB) is integrated with various types of flexible transition membranes (e.g., reinforced sheet products and/or liquid applied materials with reinforcement) and rigid material flashings (e.g., metal, PVC) to provide a continuous WRB system.

Transition flashings are used at EIFS terminations to direct water that inadvertently by-passes the primary line of defense into the EIFS drainage cavity back to the exterior of the assembly. Flashings must be incorporated into the LA-WRB in a ship-lapped, waterproof manner to direct any water that reaches the WRB back to the exterior of the wall (*ULC S716.2, Clause 8.1.6*). Flashings must be installed in a continuous manner with an outward slope. Laps and joints between lengths of flashing must be sealed in addition to being lapped.

EIFS manufacturers provide typical illustrations for flashings to be used at EIFS terminations. The illustrations show the design intent but should not be applied to a specific project and be used as a replacement for project specific details. Generic illustrations are provided in Appendix A of this manual for reference.

Note: The Architectural Sheet Metal Manual by the Sheet Metal and Air Conditioning Contractors National Association Inc. (SMACNA) is a good resource for rigid metal flashing detailing.

Flashings must be located under any horizontal termination of the EIFS, including

1. Where the EIFS terminates above another cladding system, (see Illustrations 14-25 in Appendix A) *Note: There may be instances where this is not necessary i.e. where the WRB is continuous behind a different cladding that is provided at grade level with drainage to the exterior).*
2. Where an EIFS wall terminates at a balcony or lower roof, (see Illustrations 15-25 in Appendix A)
3. At the head of windows or doors (and at the sill), (see Illustrations 02-25 to 06-25 in Appendix A)
4. At horizontal expansion joints intended to drain water (at a minimum of every 2nd floor level unless permitted or required otherwise by the EIFS manufacturer), (see Illustrations 11-25 in Appendix A)

Where rigid flashings are used to direct water out of the cladding (and/or to protect upper EIFS surfaces), they are to be provided with a drip edge to direct water away from the wall surface. The edge of the drip should project 25 mm (1 in.) beyond the wall surface. When sealant is used at the underside of the drip edge flashing, care must be taken not to extend the sealant out to the edge of the drip as this will reduce the effectiveness of the drip and direct water onto the EIFS.

EIFS that terminate at horizontal elements, such as at-grade, roofs, terraces or balconies, are exposed to increased wetting due to rainwater splash and snow piling/drifts. The following clearances are required:

1. Where EIFS are installed above projecting building elements, such as roofs, balconies, or other similar horizontal elements, the bottom edge of EIFS shall be terminated a minimum of 50 mm (2 in.) above such projecting building elements (*ULC S716.2, Clause 9.2.2.5 and ULC 716.3, Clause 12.1.2*).
2. A clearance of at least 200 mm (8 in.) shall be maintained between the EIFS termination and finished grade (*ULC S716.3, Clause 12.1.3*).

In addition to protection for the EIFS, these clearances also allow for repair or replacement of waterproofing seals or flashings that tend to exist at these areas without disturbing the field of the EIFS.

Where the lower edge of a sloped roof abuts an EIFS clad wall is a critical interface. A diverter flashing should be installed at these interfaces to direct water away from the face of the wall (see Illustrations 19-25 in Appendix A).

Similarly, drip deflectors/end dams should be installed at the ends of flashing at window and door sills (see Illustrations 02-25, 04-25, 05-25, 06-25 in Appendix A)

3.4 Air and Vapour Control

Moisture is the primary source of premature deterioration in building envelope assemblies. Moisture can come from:

- Direct liquid exposure from rain and melting snow (Section 3.2); and/or,
- From water vapour in the air, primarily from the interior, due to vapour diffusion through building materials and/or by vapour flow into assemblies via air leakage. Interior vapour is generated by the activities of living, such as washing dishes, bathing, drying clothes and even breathing. Improperly designed and constructed assemblies without proper air and vapour control can develop condensation and mould problems.

The intent of this manual is not to describe the building science involved with these mechanisms in detail but rather how EIFS controls air and vapour flow directly.

3.4.1 Vapour Control

Reduced condensation potential is a widely acknowledged advantage of continuous, exterior insulation³. There is a strong relationship between vapour control and control of heat flow. When continuous EIFS insulation of adequate thickness is used as the primary component of a wall assembly thermal resistance control strategy and positioned as the cladding; vapour control is usually achieved at the same time. The reasons for this are as follows:

- Components within the wall assembly that are moisture sensitive (i.e. framing, sheathing, interior finishes) are kept warm and above the dew point temperature; greatly reducing the potential for condensation;
- Thermal bridging is minimized due to the continuous insulation, greatly reducing the potential for condensation; and,
- Thermal movements of the air and vapour control layers and their substrates are minimized increasing the longevity and performance of these components, and thereby reducing the potential for condensation long term.

During hot and humid weather, particularly if the walls are exposed to solar radiation on the outside or if the building interior is cooled, the flow of vapour can be from exterior to interior. The rate of vapour diffusion through the wall depends on the vapour permeability of the various wall components, including the EIFS lamina, the insulation, the WRB, and interior vapour barriers/retarders. Such a mechanism is generally not a problem with EIFS unless the system and perimeter seals and assemblies are not well maintained and allow water into the EIFS which increases the vapour pressure drive from the exterior to interior.

Generally a traditional polyethylene or other type of vapour barrier applied behind the interior finishes is often not an essential component of a wall assembly clad with an adequate thickness of EIFS insulation. Some WRB products may also perform as a vapour barrier or retarder. In such cases, it is generally recommended that all insulation be installed outboard of the vapour barrier or retarder.

³ How to Arrive at the True Value Propositions of EIFS, Ted Kesik, Ph.D., P.Eng., 2012, <http://www.eifscouncil.org/>.

When supplementary insulation is provided inside of the EIFS in the stud cavity, there can be increased risks for condensation within the wall assembly (especially when there is insufficient insulation outboard of the cavity). During winter conditions, the additional insulation prevents warming of the exterior EIFS substrate and framing, moving the dew point out of the EIFS insulation and inward to moisture sensitive components.

For small quantities of supplemental insulation, a static hygrothermal analysis may be employed to confirm that the dew point is not moved out of the EIFS insulation. The static analysis may be as simple as calculation of the thermal and vapour pressure gradients across the wall system for several interior and exterior environmental conditions. Some products are much more suitable as supplemental insulation (i.e. spray polyurethane foam) due to their air and vapour control benefits.

If greater amounts of supplemental insulation are desired, a dynamic, computer-based hygrothermal analysis should be completed. A hygrothermal analysis should also be conducted when EIFS is to be applied to an existing structure. Such an analysis accounts for local weather patterns and can estimate the extent to which moisture and vapour penetrate from both interior and exterior sources. The extent to which moisture has accumulated within the cladding during each season is estimated. The humidity or moisture accumulation at sensitive components and the time it is present before evaporating can be examined to predict whether deterioration is likely, or whether protective measures (such as coatings, or zinc based corrosion protection) can be relied upon to achieve acceptable durability. The model should also consider the relative vapour permeability of the vapour barrier, the WRB and the EIFS to avoid trapping moisture in the wall system. This analysis should be conducted and interpreted by an experienced professional who understands the limitations and practical application of the results.

3.4.2 Air Leakage Control

An effective air barrier system is a required part of the building envelope assembly. To be effective, the air barrier must be resistant to air leakage, continuous, sufficiently structural to resist wind loads or supported by a substrate, and be durable. If an adequate air barrier is not achieved, bulk air movement through the cladding can lead to significant moisture accumulation within the wall system and associated deterioration.

The air barrier may be located anywhere within the wall assembly. The ideal location considers construction sequencing, the ability to achieve effective air seals at joints and interfaces during installation, and the risk for the air barrier deteriorating or becoming damaged during construction or during its service life. For EIFS, the most common location for the air barrier is at the substrate.

More often, the water resistive barrier also serves as the air barrier in an EIFS-clad wall. This approach is the preferred approach since the WRB is well protected and fully supported by a substrate and is usually not exposed to in-service damage. The number of penetrations to seal is reduced, and continuity across floors and interior partition walls is more easily achieved. Where drainage beneath window and door sills is required, achieving proper air seals requires attention. In such cases, the air barrier shall be installed in such a manner that it extends around and seals to the inside surface of the penetrating component.

3.5 Impact Resistance

EIFS can be vulnerable to impact damage or punctures due to the thin lamina. While repairs to correct impact damage or punctures can be minimal and adequately managed by maintenance, upgrading the lamina thickness should be considered at specific locations to improve durability. Therefore, areas that are expected to see increased impact loads should be identified during the design phase and measures should be incorporated to either improve the impact resistance of the EIFS or prevent impacts from occurring (*ULC S716.3, Clause 8.1*). Building areas subject to impact loads include the following:

1. ***At-grade:*** Activities near grade can lead to the EIFS being hit by people, bicycles, lawnmowers, gardening tools, snow removal equipment, shopping carts, garbage bins, automobiles, ladders, etc. The design can limit such impacts by incorporating barrier features, such as bollards, curbs, or planters, which separate the EIFS from the impact risk.
2. ***Balconies and terraces:*** Normal activities in these areas involving people, chairs, barbeques, wheeled carts, etc., can result in impact loads on the EIFS.
3. ***Projectiles:*** Hard objects may be thrown at EIFS. This is a particular concern in areas where children play, such as schoolyards, sports areas, and playgrounds. Wind-borne projectiles can also cause damage EIFS during severe weather.
4. ***Suspended maintenance activities:*** Activities related to window cleaning and building maintenance that rely on ladders, bosun's chairs, and swing stages can be sources of impact. Persons accessing the exterior cladding for inspection or maintenance can also damage EIFS. Projecting details, such as sills, cornices or ledges, can be damaged by the cables and ropes used by suspended access equipment. Projecting details should be avoided in areas that may be affected by suspended maintenance activities or they should be provided with special protection or support.

The impact resistance of EIFS can be improved by providing heavier and/or additional layers of reinforcing mesh and base coat. The manufacturer should be consulted for system-specific methods to meet the requirements of a given situation. However, where abuse or persistent and high impact loads are likely, such as immediately adjacent to roadway/parking areas, loading docks, and walkways at schools and shopping malls, unless consideration is given to providing bollards, plantings or other means of protection in these areas, EIFS is generally not a suitable cladding choice.

The EIFS Materials Standard requires that the impact resistance of the EIFS be tested by dropping a steel ball onto test samples (*ULC S716.1, Clause 5.5.1*). Different loads are imparted to the test sample through the use of steel balls of different weights, different diameters, and using different heights from which to drop the ball.

3.6 Retrofit

EIFS are particularly suitable for retrofitting existing buildings because:

- A new, improved, architectural appearance can be provided;
- The light weight can usually be accommodated by the existing structure and substrate with little or no reinforcing;
- The thermal resistance of the continuous insulation improves energy efficiency, reduces thermal bridging and condensation potential;
- Existing wall assemblies experiencing problems with leakage or deterioration, are protected from further deterioration and the extent of repairs to the existing cladding can generally be greatly reduced; and
- Water penetration problems can be corrected.

Most principles presented in this Manual apply to both new construction and retrofit applications. However, retrofit applications can introduce additional considerations that need to be addressed by the design. At a minimum, the following should be assessed when retrofitting with EIFS:

1. Structural Adequacy of the Substrate

Determining the structural adequacy of the substrate in a retrofit situation may be difficult due to various factors including the lack of drawings and details pertaining to the original design or the lack of compliance of the building with current building codes. However, identifying defects in the existing structure and substrate that may impact the installation of the EIFS is critical. Prior to applying the new EIFS cladding, remediation of the existing substrate required to provide the necessary structural integrity for the new cladding must be undertaken.

2. Surface Contaminants

An existing cladding may be weathered and contaminated and may require specialized cleaning prior to being retrofitted with EIFS. Existing paints – especially alkyd paints, coating, sealers and sealant on cladding surfaces may prevent proper adhesion of the new EIFS and its components. As such, the suitability of the existing cladding in being retrofitted with EIFS shall be evaluated. Field testing is to be performed to verify proper adhesion of materials applied to the existing weathered substrate.

3. Cladding Deterioration

EIFS provide the opportunity to protect existing claddings that are experiencing problems with deterioration by reducing exposure to water and maintaining.

EIFS installed over masonry or concrete walls can help control deterioration of these claddings and can help control corrosion of steel anchors or reinforcing steel. An experienced professional should be involved in determining whether EIFS are suitable in these situations, and developing a design that can achieve acceptable performance.

4. Moisture Management

Designers and specifiers shall consider how the existing cladding will be affected and how it will perform following installation of the retrofit EIFS. Older wall assemblies may not have adequate air and vapour control. In most situations, the retrofit EIFS will perform well when an air/water resistive barrier is applied behind the EIFS. A hygrothermal analysis of the proposed design should be performed by an experienced professional to identify any potential problems with the new wall assembly.

5. Interfaces

Interfaces: When designing an EIFS for retrofit, designers and specifiers should allow for future replacement of existing building components such as windows, doors, and roofs without damaging the new EIFS cladding. Consideration should be given to renewing these other elements in conjunction with the EIFS application.

4. SAMPLE EIFS INSTALLATION CHECKLIST

The following checklist was developed for the EIFS Quality Assurance Program Inc. (EQI).

Substrate Temperature (°C):	<input type="text"/>	Sunlight Exposure:	<input type="text"/>	Supplemental Heat Used: (Y/N/N/A)	<input type="text"/>
Within Limits: (Y/N)	<input type="text"/>	Clean: (Y/N)	<input type="text"/>	Dry: (Y/N)	<input type="text"/>
Smooth: (Y/N)	<input type="text"/>	Efflorescence Removed: (Y/N/NA)	<input type="text"/>	Substrate Installation Complete to Receive WRB: (Y/N)	<input type="text"/>

Glass Fibre Faced Gypsum Sheathing Board	
Installed by EIFS Mechanic (Y/N)	<input type="text"/>
Board edges supported by framing (Y/N/Not checked)	<input type="text"/>
Fastener type, length and spacing as per manufacturer requirements (Y/N/Not checked)	<input type="text"/>
Fasteners tight and flush to sheathing surface and not countersunk (Y/N/Not checked)	<input type="text"/>
Long dimension of boards installed at right angles to framing members (Y/N/Not checked)	<input type="text"/>
Board joints installed tight but not forced together (Y/N/Not checked)	<input type="text"/>
Joints prepared with fibreglass mesh (Y/N/Not checked)	<input type="text"/>
Control joints provided as specified (Y/N/Not checked)	<input type="text"/>

Water Resistive Barrier (WRB)

Is the WRB also a component of the air barrier system? (Y/N)			
Is the WRB also a component of the vapour barrier system? (Y/N)			
Metal flashings installed where and as specified? (Y/N)		Metal flashings installed by Others? (Y/N)	
Flexible transition membrane flashings installed where and as specified? (Y/N)		Flexible flashings installed by Others? (Y/N)	
Flexible transition membrane – primer used? (Y/N)		Flexible transition membrane – roller used? (Y/N)	
Flexible transition membrane – Installed at window and door perimeter rough opening as specified (Y/N)		Acceptable (Y/N)	
Flexible transition membrane – Installed at window and door perimeter rough opening between substrate and onto window/door frame if specified (Y/N)		Acceptable (Y/N)	
Flexible transition membrane – Installed at roof parapet (Y/N/NA)		Acceptable (Y/N)	
Flexible transition membrane – Installed at expansion/control joints in wall sheathing (Y/N/NA)		Acceptable (Y/N)	
Flexible transition membrane – Installed at joints between dissimilar materials (Y/N/NA)		Acceptable (Y/N)	
Flexible transition membrane – Installed overtop of metal flashings at horizontal terminations intended to drain water (Y/N/NA)		Acceptable (Y/N)	
EIF System drainage/starter tracks properly installed (Y/N/NA)			
Is the WRB continuous and will it drain water? (Y/N)			
WRB Measured Thickness	_____ mm	Acceptable (Y/N)	

Insulation Attachment and Back-Wrapping

Efflorescence removed from air/moisture barrier prior to insulation attachment (Y/N/NA)			
Pre-back wrapped boards used at horizontal termination joints where drainage is to be provided. Mesh is fully encapsulated in base coat (Y/N)		Acceptable (Y/N)	
Full base coat and mesh back wrap onto substrate (minimum 3 in.) provided at all terminations. Mesh is fully encapsulated in base coat (Y/N)		Acceptable (Y/N)	
Tie-in mesh used at terminations at board joints (Y/N)		Acceptable (Y/N)	
Mesh back wrap provided at heat emitting devices (Y/N)		Acceptable (Y/N)	
Auditor had random insulation boards removed/cut to verify that 1) drainage paths are free of obstruction (Y/N), 2) drainage paths are of required gap depth (Y/N) and, 3) there is adequate attachment to substrate (Y/N)		Acceptable (Y/N)	
Boards installed tight to each other (Y/N)		Acceptable (Y/N)	
Insulation boards are staggered in running bond pattern with vertical joints offset (Y/N)			
Insulation board joints are not aligned with sheathing board joints (offset a minimum of 6 in.) (Y/N)			
Insulation thickness at reveals following rasping is greater than 20 mm (3/4 in.) (Y/N)			
L-cut boards provided around openings (Y/N)			
Boards interlocked at inside and outside corners (Y/N)			
Adequate clearance provided around openings, penetrations and expansion joints which are to receive sealants (Y/N)			
Surfaces without metal flashings are sloped to drain water as specified (minimum 6:12 (50%) or 3:12 (25%) for low exposure areas) (Y/N)			
Slivers of insulation used at board joints (Y/N)		Acceptable (Y/N)	
Spray foam use at boards joints keep to a minimum (Y/N)		Acceptable (Y/N)	
Control joints provided as and where specified (Y/N/NA)		Acceptable (Y/N)	
Insulation board surface is smooth and rasping complete (all surfaces to be rasped) (Y/N)		Acceptable (Y/N)	

Base Coat and Reinforcing Mesh

Mesh Types and Weight
(oz) as Specified: (Y/N)

Type:

Detail ____ oz, Standard ____ oz, Intermediate ____ oz,
High Impact ____ oz.

UV damage (if applicable) removed prior to base coat application (Y/N/NA)		Acceptable (Y/N/NA)			
Diagonal mesh is provided at opening corners (i.e. windows and doors) (Y/N)		Acceptable			
Proper mesh overlap is provided at field of walls and corners (Y/N)					
Mixed in accordance with EIFS manufacturer requirements (Y/N)					
Insulation is dry and smooth (Y/N)					
Base coat applied to insulation board, then mesh applied ovetop (Y/N)					
Mesh is wrinkle free (Y/N)					
High impact mesh applied in specified areas (Y/N/NA)					
Number of coats applied (1 or 2)					
Reinforcing mesh colour visible through base coat (Y/N)					
Significant reinforcing mesh pattern visible through base coat (Y/N)				Acceptable (Y/N)	
Measured minimum base coat thickness (not average) Check 3 locations as a minimum. If reinforcing mesh pattern is not visible through base coat, measuring is not required.	_____mm			Acceptable (Y/N)	
Base coat thickness at reveals is acceptable (Y/N)					
Base coat thickness at joints to receive sealant is acceptable (Y/N)					
Finished base coat is smooth and ready to receive finish coat (Y/N)					
Another application of base coat is required (Y/N)					

Finish Coat

Finish coat primer applied if specified (Y/N)		Acceptable (Y/N)	
Finish coat primer applied at joints to receive sealant if specified (Y/N)		Acceptable (Y/N)	
Base coat affected by exposure to precipitation (Y/N)			
Efflorescence removed prior to finish coat application (Y/N)		Acceptable (Y/N)	
Mixed in accordance with EIFS manufacturer requirements (Y/N)			
Finish coat thickness at field of wall is acceptable (Y/N)			
Finish coat thickness at reveals is acceptable (Y/N)			
Finish coat texture and colour as per approved mock-up (Y/N)			
Finish coat terminated at joints to receive sealant so that sealant can be applied onto base coat only (Y/N) (Not applicable if sealant is permitted to be applied to finish coat primer)		Acceptable (Y/N)	
Finish coat affected by exposure to precipitation (Y/N)			

Sealants (on EIFS surfaces)

Sealant joint substrate acceptable to receive sealants (Y/N)	
Bond breaker materials installed as specified (Y/N)	
Primer applied as specified (Y/N)	
Sealant bead profiles acceptable (Y/N)	
Dual staged seals installed if specified? (Y/N/NA)	
Drainage weep holes and vents installed as specified? (Y/N)	

5. GLOSSARY

ADHESIVE - a product for adhering the thermal insulation board to the substrate or water resistive barrier system.

AESTHETIC REVEAL - a groove cut into the thermal insulation board for decorative purposes only.

AIR BARRIER SYSTEM – a three-dimensional assemblage of materials that is designed to provide the primary resistance to airflow through an enclosure. May be an air-vapour barrier when its function also includes the control of vapour diffusion.

BACKER ROD – a resilient material (typically closed-cell polyethylene) formed into a circular cross-section and provided in rope form, placed in a seam or joint to provide backing, act as a bond breaker, and allowing an appropriate profile to be formed when applying sealant.

BASE COAT - a polymer based coating, either factory-blended or field-mixed, applied directly to the thermal insulation board, fully embedding the reinforcing mesh, providing the primary barrier to water penetration.

BOND BREAKER – a tape, sheet, wax pencil or liquid applied material that prevents adhesion on a designated surface. See also Backer Rod.

CAPILLARY ACTION – the movement of water within the narrow spaces of a porous material or between materials due to the forces of adhesion, cohesion, and surface tension. Capillary action explains how liquid water is transported through cracks in concrete, wood, brick, etc.

CAPILLARY BREAK – a material, or an air space, in an assembly that permits little or no capillary action, and hence breaks the transport of liquid water through an assembly made up of porous materials. Metals, glass, plastics, bitumen, etc. are often used as capillary breaks between, for example, concrete and wood.

CEMENT BOARD – a sheathing product made of cement-bonded, fibre-reinforced composites (typically glass or wood fibres are used as reinforcing). Cement board is moisture and fire resistant and is used as a substrate sheathing. Refer to ASTM C1186, “Standard Specification for Flat Fiber-Cement Sheets”.

COMBUSTIBLE - A material that does not meet the requirements of CAN/ULC-S114.

COMBUSTIBLE CONSTRUCTION - A type of building construction that does not meet the requirements for non-combustible construction.

CRACK – a narrow opening in the finish and/or base coat. The result of forces that exceed the strength of a material at a particular location.

CURE - to develop the ultimate properties of an initial wet state material by a chemical process.

DETERIORATION – visible cracks, fissures, excessive indentation or other undesirable changes in the surface of the EIFS.

DRAINAGE CAVITY - a space between the substrate and the thermal insulation board that allows for the free drainage of water that penetrates the EIFS.

DRIP EDGE – a geometric feature provided in an exterior building surface to ensure that flowing water will drip free rather than be pulled back toward a vertical enclosure element. A drip groove is commonly employed in solid materials like concrete, whereas a drip edge is used for thinner sheet materials.

DRY - to develop the ultimate properties of an initial wet state material solely by evaporation of volatile ingredients.

DURABILITY - The ability of a building (or any of its components) to perform its required functions in its service environment over a period of time without unforeseen cost for maintenance or repair.

EIFS MANUFACTURER - the producer of the materials and components forming a proprietary EIFS.

EIFS CONTRACTOR - the legal entity (corporate or personal) that is responsible for the site installation of the LA-WRB and all materials and components that make up an EIFS. Note: The EIFS contractor may or may not be responsible for installation of transition membranes.

EIFS MOULDING - an insulation profile that is mounted on or incorporated into the thermal insulation boards and covered by the EIFS lamina.

EIFS PROPONENT – the party applying for a CCMC evaluation (normally the manufacturer of a product, a major component supplier or a Canadian distributor of the product).

EMBED - to press into and encapsulate the reinforcing mesh in the wet base coat.

END-DAM – a vertical or near vertical upstand from the end of a flashing, or window sill, used to prevent water from flowing horizontally off the end of the flashing or sill.

EXPANDED POLYSTYRENE (EPS) – a rigid cellular foamed polystyrene plastic insulation material manufactured by expansion of expanded polystyrene beads within a mould. This mould creates an open cell structure filled with air. EPS Type I is the most widely used insulation for EIFS applications, with a density of 16 kg/m³ (1 lb/ft³); Type II has a density of 24 kg/m³ (1.5 lb/ft³).

EXPANSION JOINT - a joint designed to permit movement due to expansion and contraction of any part of the system (CAN/ULC-S773).

EXTERIOR INSULATION AND FINISH SYSTEM (EIFS) - a non load-bearing wall cladding system comprised of thermal insulation board, an adhesive for attachment of the thermal insulation board to the substrate, a glass fibre reinforcing mesh embedded in a base coat on the face of the thermal insulation board and a finish coat. Note: In Europe, the equivalent term to EIFS is ETICS – External Thermal Insulation Composite System.

EXTRUDED POLYSTYRENE (XPS) – a rigid cellular polystyrene foamed-plastic insulation material manufactured by extrusion of polystyrene in the presence of a blowing agent. The blowing agent dissipates out of the closed cell structure over time creating a structure that resists liquid water penetration and vapour diffusion. The manufacturing process for XPS insulation results in a smooth surface skin, which may require additional treatment in order to ensure the proper adhesion of EIFS coatings.

FACTORY-BLENDED - any material that arrives from the manufacturer requiring no additions apart from water to produce the wet state material.

FIBREGLASS-FACED Gypsum Sheathing– an increased moisture resistant type of exterior gypsum sheathing. The gypsum core is silicone treated for water repellency and the glass matt applied to each face as reinforcement meets the requirements of ASTM C1177, “Standard Specification for Glass Mat Gypsum Substrate for Use as Sheathing”.

FIELD-MIXED - materials that are mixed in the field by combining two or more materials, other than, or in addition to, water.

FINISH COAT - the outermost coat applied over the base coat, which gives the EIFS its colour and texture, exclusive of sealers and paints.

FLASHING – continuous material(s) that stops the vertical flow of water within a wall assembly or system and directs the water, via gravity, to the exterior of the wall.

GEOMETRICALLY DEFINED DRAINAGE CAVITY (GDCC) - A space created between the substrate and thermal insulation board through the use of thermal insulation board that has a pattern cut into its back.

JOINT – an interface between elements. Joints may be needed to allow for movement of different parts of a building or assembly, or may be required to make construction sequences practical. In all cases, the functional requirements of the enclosure must be maintained the same as for the body of an enclosure element, although aesthetic requirements may be relaxed. A joint may pass through the entire enclosure assembly, in which case it is a building movement joint, or more commonly referred to as an expansion joint.

LAMINA – a composite of base coat, reinforcing mesh and finish coat.

LIQUID APPLIED WATER RESISTIVE BARRIER (LA-WRB) - a fluid material applied by spray, roller or trowel, that dries to a membrane possessing low water absorption properties becoming a component of the water resistive barrier system.

MANUFACTURER'S PUBLISHED INSTALLATION INSTRUCTIONS - written installation instructions provided by the EIFS manufacturer that include information that will assist in the correct use and installation of the materials and components that comprise their system.

MECHANICAL FASTENER – a means to fasten thermal insulation board to the building structure (usually a screw and a special fastener washer) of various proprietary types as offered by certain manufacturers.

NON-COMBUSTIBLE - A description of a material that meets the requirements of CAN/ULC-S114.

NON-COMBUSTIBLE CONSTRUCTION - A type of building construction in which the degree of fire safety is attained by the use of non-combustible materials for structural members and other building assemblies.

PERFORATION – broken or damaged reinforcing mesh.

POT-LIFE - the period of time during which a material maintains its workable properties after it has been mixed. Note: Pot-life is a function of temperature; the higher the temperature, the shorter the pot-life.

PRIMER – a coating intended to prepare a surface for the subsequent application of another material, such as the surface of the substrate prior to the adhesive application, or the surface of the base coat prior to the finish coat application.

REINFORCING MESH - a woven or non-woven glass fibre fabric component of the EIFS encapsulated in the base coat to strengthen the EIFS.

SEALANT – a flexible, elastomeric material used in the assembly of the building enclosure to cover gaps, seams or joints to provide a clean finish, to waterproof, or to provide airtightness.

SUBSTRATE - the structural component supporting the EIFS, which is resistant to deterioration caused by water or is protected by a water resistive barrier system.

TEXTURE – any surface appearance as contrasted to a smooth surface.

THERMAL INSULATION BOARD - a component that functions to reduce heat flow through the wall and serves as the surface to receive the base coat.

TRANSITION MEMBRANE - a component of the water resistive barrier system that maintains continuity of the WRB at joints and openings in the substrate that cannot be bridged with the LA-WRB.

VAPOUR PERMEANCE – A material layer or enclosure assembly property that describes how easily water vapour diffuses (i.e., moves from high to low concentration) through it. The units typically used are metric perms [$\text{ng}/(\text{Pa}\cdot\text{s}\cdot\text{m}^2)$] or US perms [$\text{grain}/(\text{hr}\cdot\text{ft}^2\cdot\text{in Hg})$]. One US perm equals 57 metric perms. A 6 mil sheet of polyethylene has a vapour permeance of 3.4 $\text{ng}/\text{m}^2/\text{s}/\text{Pa}$. The lower the permeance number, the more vapour retardant the material.

VAPOUR RETARDER – A layer within an enclosure assembly that is intended to control diffusive vapour flow. A Type I vapour retarder has a permeance of 15 $\text{ng}/(\text{Pa}\cdot\text{s}\cdot\text{m}^2)$ or less. A Type II vapour retarder has an initial permeance of 45 $\text{ng}/(\text{Pa}\cdot\text{s}\cdot\text{m}^2)$ and 60 $\text{ng}/(\text{Pa}\cdot\text{s}\cdot\text{m}^2)$ or less, after aging. Also called a vapour barrier or vapour diffusion retarder or an air-vapour barrier when its function is combined with that of the air barrier.

WATER ABSORPTION COEFFICIENT – the mass of water absorbed by a test specimen under specified time and pressure, per unit area and per square root of time.

WATER DRAINAGE – the ability of the test specimen to drain water and measured as the weight of water collected from the test specimen drainage space.

WATER RESISTIVE BARRIER SYSTEM (WRB) - material(s) possessing low water absorption properties that are applied over substrates susceptible to water absorption to create a continuous surface that prevents water penetration into the wall assembly. The WRB is composed of the LA-WRB and transition membranes. The WRB is integrated with the flashing, which drains water to the exterior of the wall.

WET STATE – the adhesive, base coat and finish coat components materials applied in liquid or semi-liquid state.

WRAP - to protect the exposed edges of thermal insulation boards by back-wrapping, edge-wrapping or pre-wrapping.

6. REFERENCES

ASTM B117-03, “Standard Practice for Operating Salt Spray (Fog) Apparatus”.

ASTM C1177/C1177M-08, “Standard Specification for Glass Mat Gypsum Substrate for Use as Sheathing”.

ASTM C1186-08, “Standard Specification for Flat Fiber-Cement Sheets”.

ASTM C1278/C1278M-07a, “Standard Specification for Fiber-Reinforced Gypsum Panel”.

ASTM C1382-05, “Test Method for Determining Tensile Adhesion Properties of Sealants When Used in Exterior Insulation and Finish Systems (EIFS) Joints”.

ASTM E96/E96M-05, “Standard Test Methods for Water Vapor Transmission of Materials”.

ASTM E2110-09e1, “Standard Terminology for Exterior Insulation and Finish Systems (EIFS).

ASTM G154-06, “Standard Practice for Operating Fluorescent Light Apparatus for UV Exposure of Nonmetallic Materials”.

ASTM G155-05a, “Standard Practice for Operating Xenon Arc Light Apparatus for Exposure of Non-Metallic Materials”.

CAN/ULC-S101-07, “Standard Methods of Fire Endurance Tests of Building Construction and Materials”.

CAN/ULC-S102-10, “Standard Method of Test for Surface Burning Characteristics of Building Materials and Assemblies”.

CAN/ULC-S102.2-10, “Standard Method of Test for Surface Burning Characteristics of Flooring, Floor Coverings, and Miscellaneous Materials and Assemblies”.

CAN/ULC-S114-05, “Standard Method of Test for Determination of Non-Combustibility in Building Materials”.

CAN/ULC-S124-06, “Test for the Evaluation of Protective Coverings for Foamed Plastic”.

CAN/ULC-S134-92(R1998), “Standard Method of Fire Test of Exterior Wall Assemblies”.

CAN/ULC-S701-05, “Standard for Thermal Insulation, Polystyrene, Boards and Pipe Covering”.

CAN/ULC-S702-97, “Standard for Mineral Fibre Thermal Insulation for Buildings”.

CAN/ULC-S704-03, “Standard for Thermal Insulation, Polyurethane and Polyisocyanurate, Boards, Faced”.

CAN-ULC-S710.1-05, “Standard for Thermal Insulation – Bead-Applied One Component Polyurethane Air Sealant Foam, Part 1”.

CAN-ULC-S710.2-05, “Standard for Thermal Insulation – Bead-Applied One Component Polyurethane Air Sealant Foam, Part 2”.

CAN/ULC-S773-09, “Standard for Thermal Insulation Terminology”.

ULC S716.1-10, “Standard for Exterior Insulation and Finish Systems (EIFS) - Materials and Systems”.

ULC S716.2-10, “Standard for Exterior Insulation and Finish Systems (EIFS) - Installation of EIFS Components and Water Resistive Barrier”.

ULC S716.3-10, “Standard for Exterior Insulation and Finish Systems (EIFS) – Design Application”.

National Building Code of Canada

LEED Green Building Rating System in Canada

EIFS Quality Assurance Program (QAP)

APPENDIX A: Illustrations 1-25

The illustrations prepared for this section of the manual are solely to depict design intent satisfying requirements for EIFS. Users of this manual are responsible to design and detail EIFS assemblies that comply with all applicable codes and standards.

Note: The insulation thickness shown in the illustrations is not representative of the required thickness for thermal insulation as required by current Building Codes.

The ECC would like to recognize and thank DuRock Alfacing International Ltd. for their donation of drafting time in the preparation of the isometric illustrations that form part of the EIFS Practice Manual.

EIFS

EXTERIOR INSULATION FINISH SYSTEMS

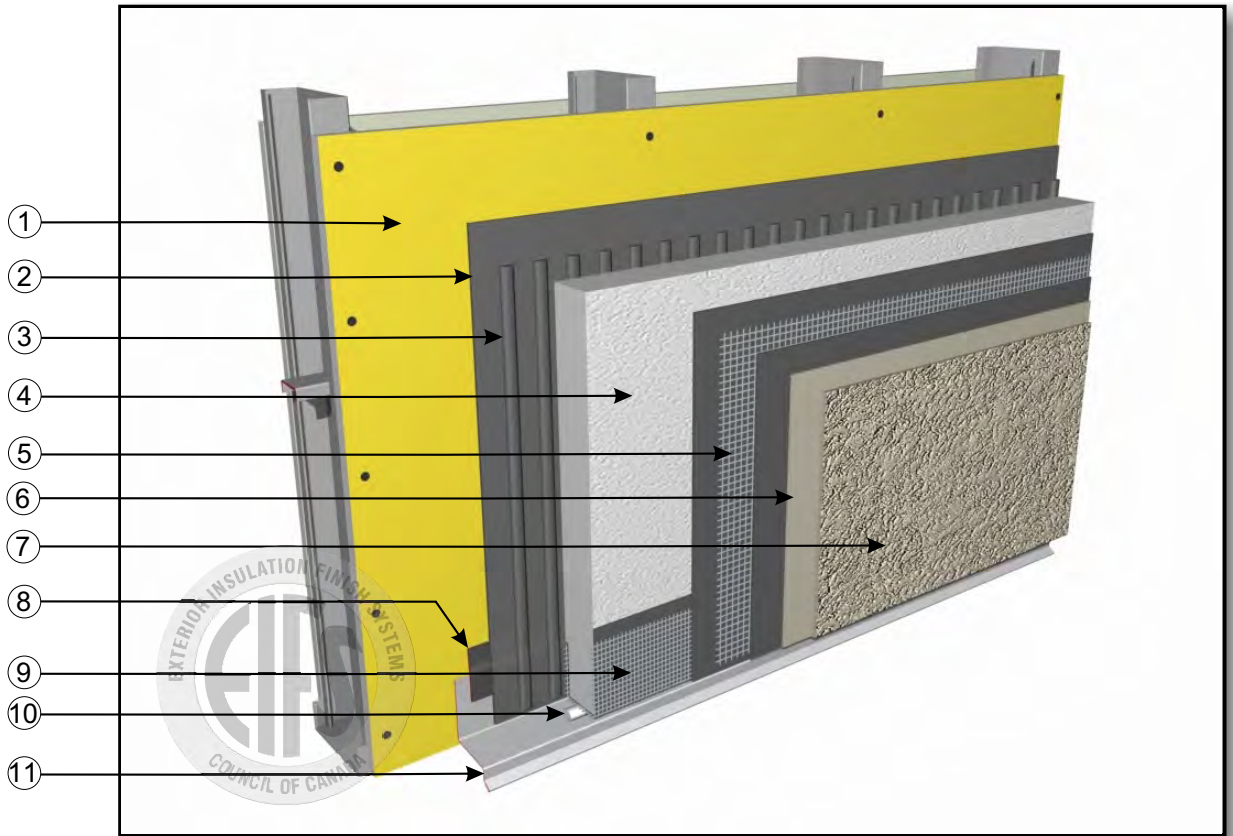

EIFS STANDARD WALL SECTION

- ① Substrate
- ② Water Resistive Barrier
- ③ Vertically Notched Adhesive or grooved insulation for drainage
- ④ Insulation Board
- ⑤ Reinforcing mesh embedded in Base Coat
- ⑥ Colour Primer if specified
- ⑦ Finish Coat (over finish coat primer if specified)
- ⑧ Transition material
- ⑨ Pre-wrap insulation at termination to allow for drainage
- ⑩ Optional Backer Rod and Sealant with drainage openings. Sealant applied to base coat as per sealant manufacturer instructions
- ⑪ Metal Flashing

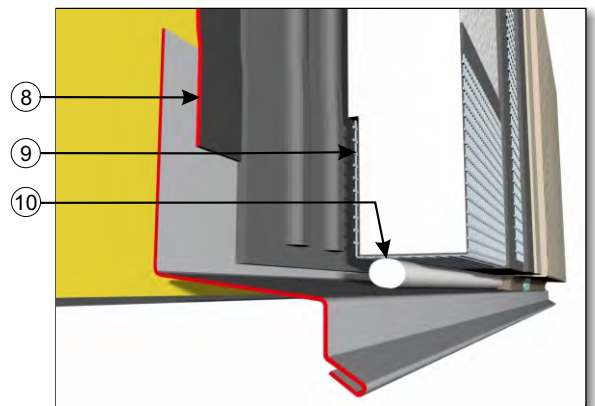

DISCLAIMER:

Any user of this EIFS Practice Manual is expressly bound by the Waiver and Disclaimer set out within this Manual. This illustration is a proprietary component of the EIFS Practice Manual and is subject to full copyright protection."

EIFS

EXTERIOR INSULATION FINISH SYSTEMS

EIFS COUNCIL OF CANADA

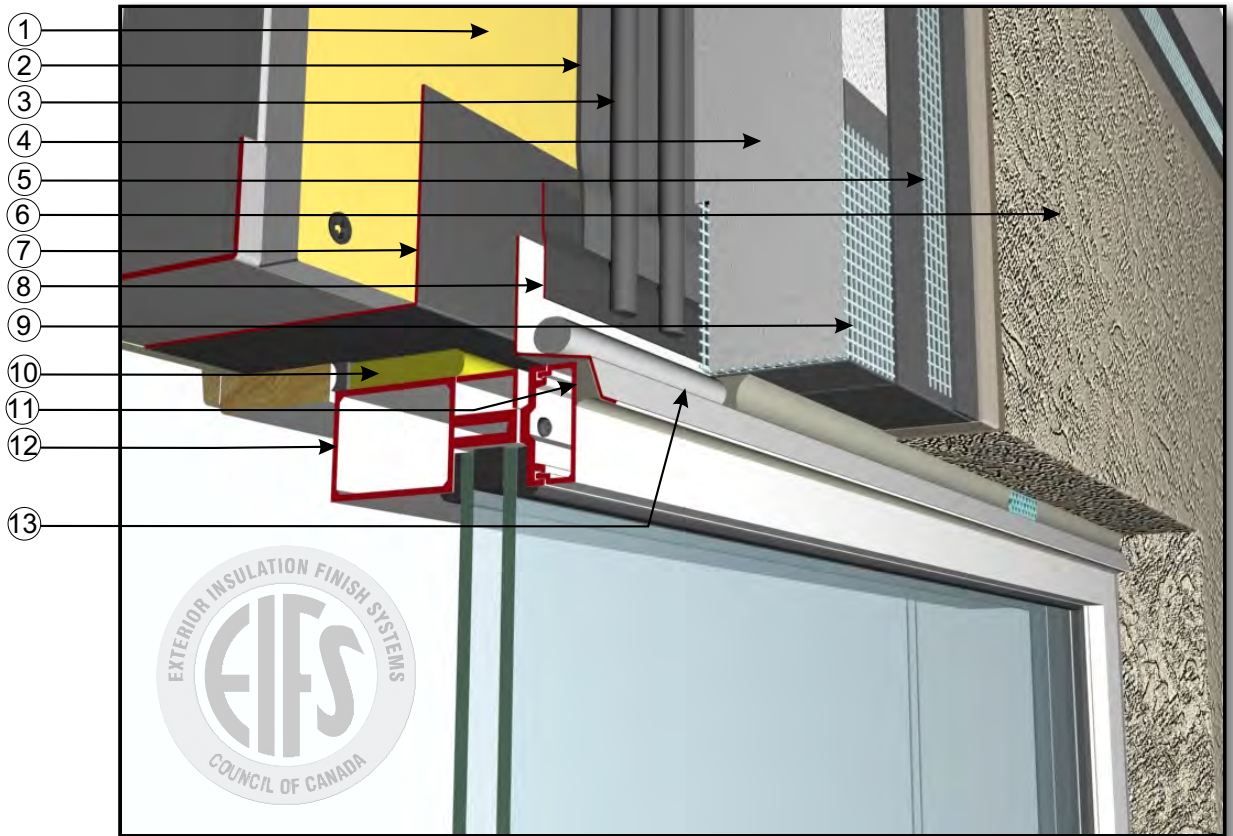

WINDOW HEAD (WINDOW INSTALLED AFTER WRB)

- ① Substrate
- ② Water Resistive Barrier
- ③ Vertically Notched Adhesive or grooved insulation for drainage
- ④ Insulation Board
- ⑤ Reinforcing mesh embedded in Base Coat
- ⑥ Finish Coat (over finish coat primer if specified)
- ⑦ Transition Material, wrapped into window rough opening
- ⑧ Transition Material, covering Flashing
- ⑨ Pre-wrap insulation at termination to allow for drainage
- ⑩ Spray Foam
- ⑪ Sealant under Flashing
- ⑫ Window Frame
- ⑬ Optional Backer Rod and Sealant with drainage openings.
Sealant applied to base coat as per sealant manufacturer instructions
- ⑭ Metal Flashing with End Dam.

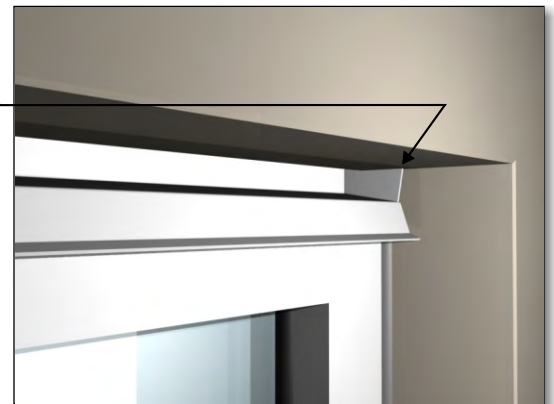

**EIFS
COUNCIL
OF
CANADA**
www.eifscouncil.org

DISCLAIMER:

Any user of this EIFS Practice Manual is expressly bound by the Waiver and Disclaimer set out within this Manual. This illustration is a proprietary component of the EIFS Practice Manual and is subject to full copyright protection."

ECC R & D

Last revise: Feb 15/13

Issued: Dec 2012

02-25

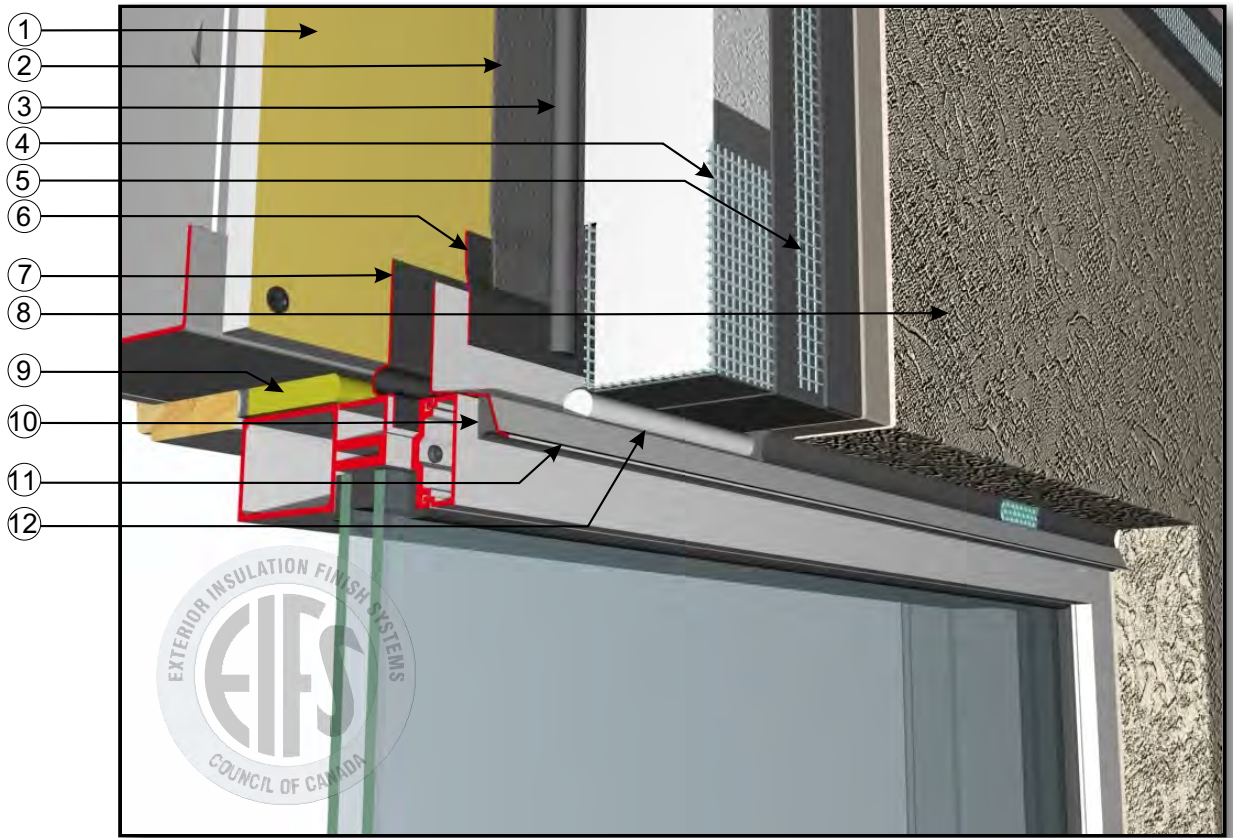

WINDOW HEAD (WINDOW INSTALLED BEFORE WRB)

- ① Substrate
- ② Water Resistive Barrier
- ③ Vertically Notched Adhesive or grooved insulation for drainage
- ④ Pre-wrap insulation board at termination to allow for drainage
- ⑤ Reinforcing mesh embedded in Base Coat
- ⑥ Transition material, covering Flashing
- ⑦ Transition material wrapped onto window frame
- ⑧ Finish Coat (over finish coat primer if specified)
- ⑨ Spray Foam
- ⑩ Sealant under Flashing
- ⑪ Metal Flashing
- ⑫ Optional Backer Rod and Sealant with drainage openings. Sealant applied to base coat as per sealant manufacturer instructions

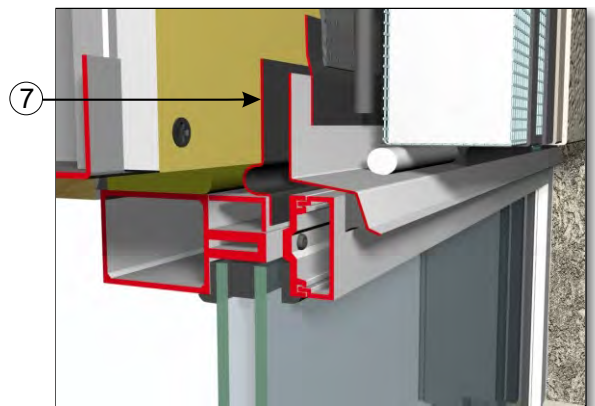

DISCLAIMER:

Any user of this EIFS Practice Manual is expressly bound by the Waiver and Disclaimer set out within this Manual. This illustration is a proprietary component of the EIFS Practice Manual and is subject to full copyright protection."

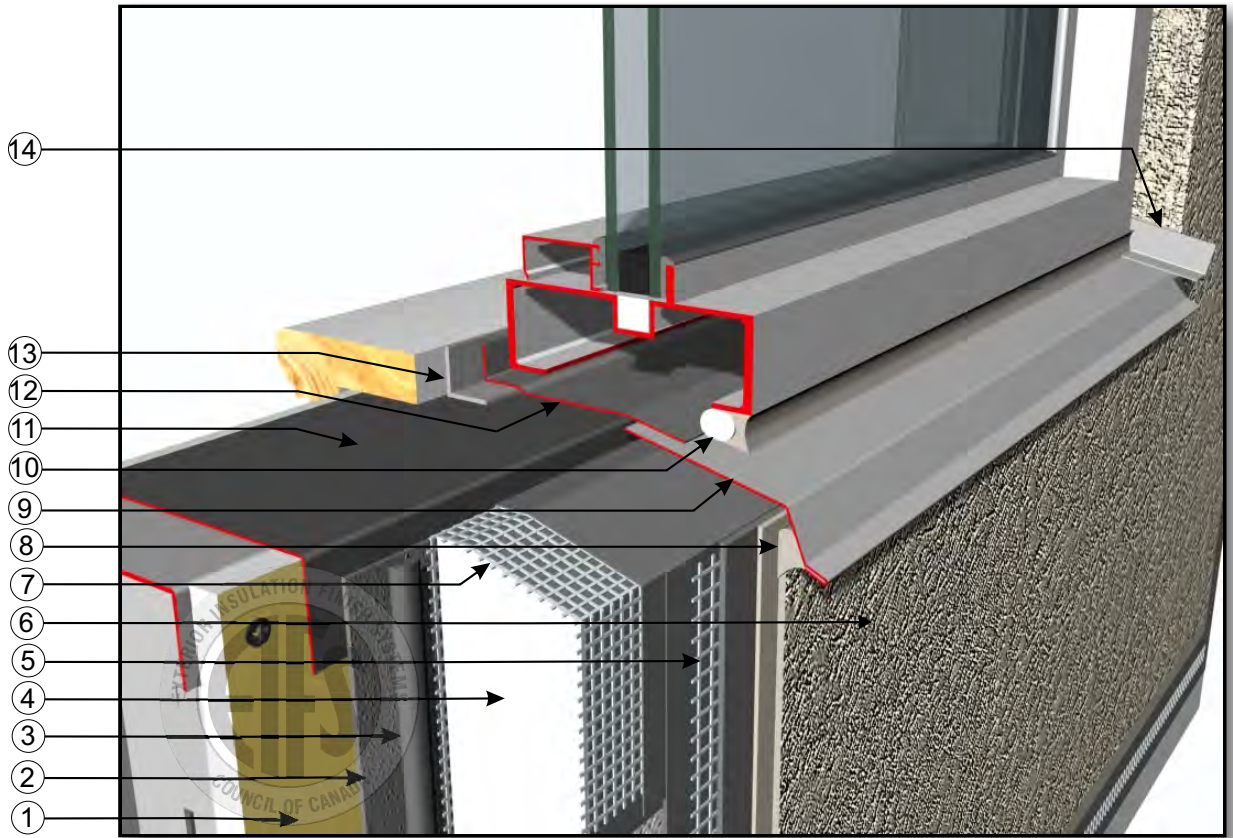

**WINDOW SILL, OPTION -A-
(MEMBRANE/METAL FLASHING COMBINATION TO CREATE SUB-SILL)**

- ① Substrate
- ② Water Resistive Barrier
- ③ Vertically Notched Adhesive or grooved insulation for drainage
- ④ Insulation Board
- ⑤ Reinforcing mesh embedded in Base Coat
- ⑥ Finish Coat (over finish coat primer if specified)
- ⑦ Back-wrapped insulation board
- ⑧ Sealant under Flashing, Sealant applied to base coat as per sealant manufacturer instructions
- ⑨ Metal Flashing with drip deflector.
- ⑩ Backer Rod and Sealant positioned not to block window system drainage
- ⑪ Transition material wrapped into window rough opening
- ⑫ Transition Membrane upturned at steel/aluminum angle to create back-dam and upturned at jambs to create end-dams
- ⑬ Steel/Aluminum angle support for transition material
- ⑭ Drip Deflector

DISCLAIMER:

Any user of this EIFS Practice Manual is expressly bound by the Waiver and Disclaimer set out within this Manual. This illustration is a proprietary component of the EIFS Practice Manual and is subject to full copyright protection."

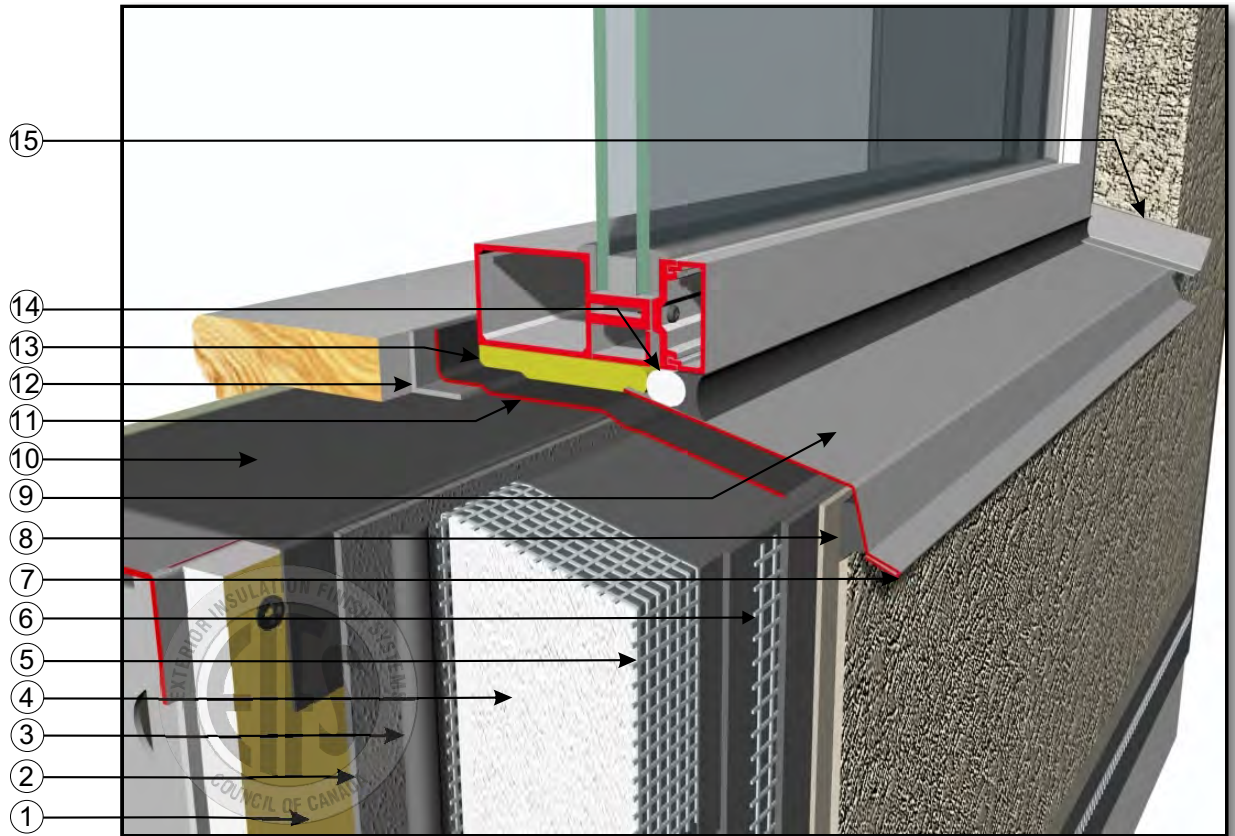

WINDOW SILL, OPTION -B- (MEMBRANE SUB-SILL)

- ① Substrate
- ② Water Resistive Barrier
- ③ Vertically Notched Adhesive or grooved insulation for drainage
- ④ Insulation Board
- ⑤ Back-wrapped insulation board
- ⑥ Reinforcing mesh embedded in Base Coat
- ⑦ Finish Coat (over finish coat primer if specified)
- ⑧ Sealant under Flashing with drainage openings.
Sealant applied to base coat as per sealant manufacturer instructions
- ⑨ Metal Flashing with Drip Deflector on both ends
- ⑩ Transition material wrapped into window rough opening
- ⑪ Transition Membrane upturned at steel/aluminum angle to create back-dam and upturned at jambs to create end-dams
- ⑫ Steel/Aluminum angle support for transition material
- ⑬ Spray foam
- ⑭ Backer Rod and Sealant positioned not to block window system drainage
- ⑮ Drip Deflector

DISCLAIMER:

Any user of this EIFS Practice Manual is expressly bound by the Waiver and Disclaimer set out within this Manual. This illustration is a proprietary component of the EIFS Practice Manual and is subject to full copyright protection."

EIFS

EXTERIOR INSULATION FINISH SYSTEMS

EIFS COUNCIL OF CANADA

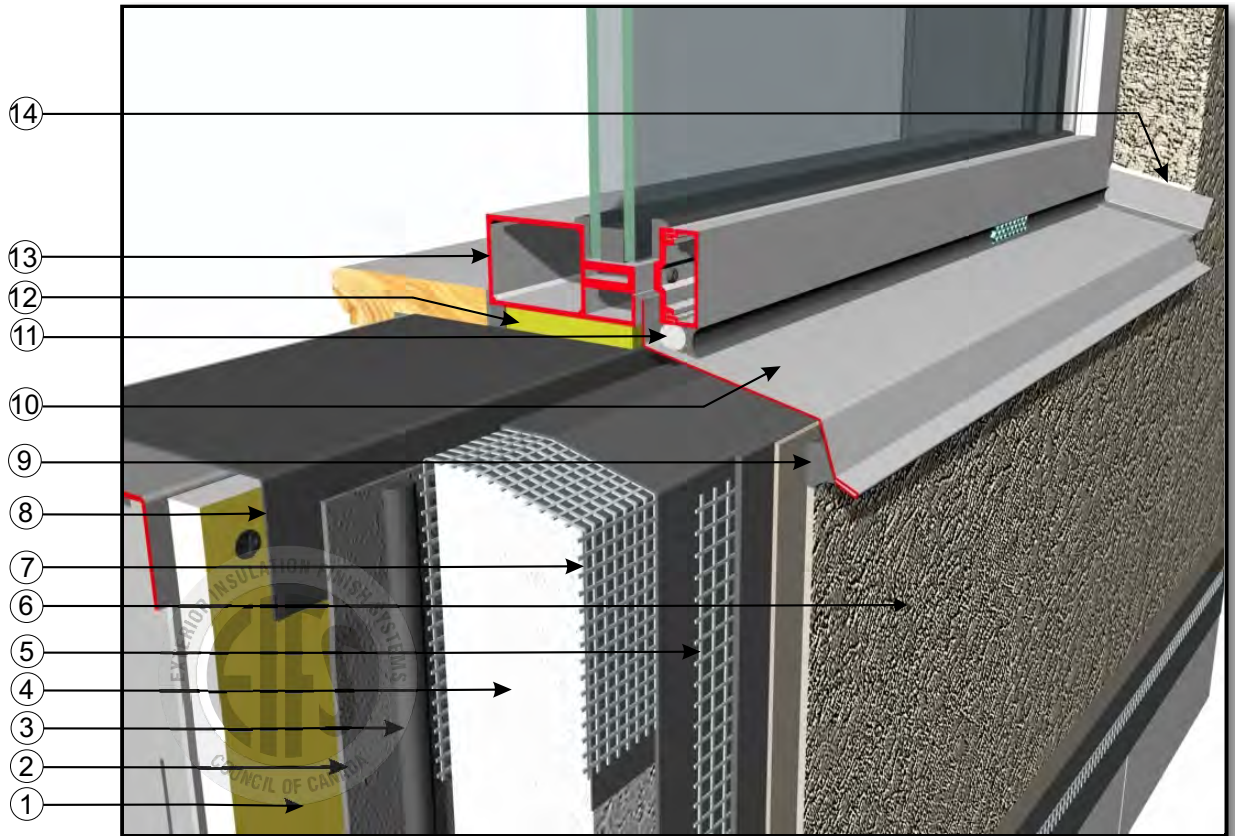

WINDOW SILL, OPTION -C- (EIFS INSTALLED AFTER THE WINDOW)

- ① Substrate
- ② Water Resistive Barrier
- ③ Vertically Notched Adhesive or grooved insulation for drainage
- ④ Insulation Board
- ⑤ Reinforcing mesh embedded in Base Coat
- ⑥ Finish Coat (over finish coat primer if specified)
- ⑦ Back-wrapped insulation board
- ⑧ Transition material, wrapped into window rough opening
- ⑨ Sealant under Flashing. Sealant applied to base coat/as sealant manufacturer's instruction
- ⑩ Metal Flashing
- ⑪ Backer Rod and Sealant positioned not to block window system drainage
- ⑫ Spray Foam
- ⑬ Window Frame
- ⑭ Drip Deflector

Note: This illustration is NOT a preferred detail. Options A or B are preferred.
This detail would typically apply to a retrofit situation.



**EIFS
COUNCIL
OF
CANADA**
www.eifscouncil.org

DISCLAIMER:

Any user of this EIFS Practice Manual is expressly bound by the Waiver and Disclaimer set out within this Manual. This illustration is a proprietary component of the EIFS Practice Manual and is subject to full copyright protection."

ECC R & D

Last revise: Feb 15/13

Issued: Dec 2012

06-25

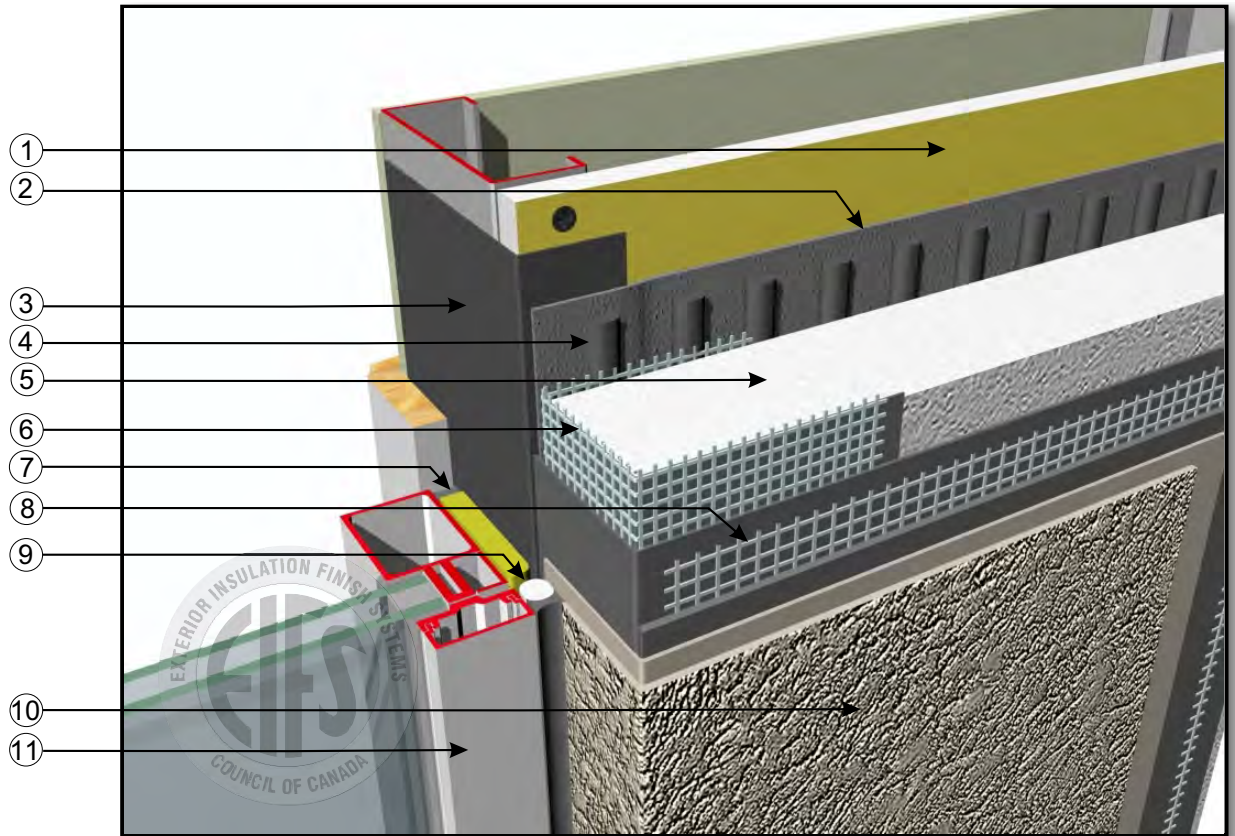

WINDOW JAMB
(TRANSITION MATERIAL AT ROUGH OPENING)

- ① Substrate
- ② Water Resistive Barrier
- ③ Transition material wrapped into window rough opening
- ④ Vertically Notched Adhesive or grooved insulation for drainage
- ⑤ Insulation Board
- ⑥ Back-wrapped insulation board
- ⑦ Spray Foam
- ⑧ Reinforcing mesh embedded in Base Coat
- ⑨ Backer Rod and Sealant. Sealant applied to base coat as per sealant manufacturer instructions
- ⑩ Finish Coat (over finish coat primer if specified)
- ⑪ Window Frame

DISCLAIMER:

Any user of this EIFS Practice Manual is expressly bound by the Waiver and Disclaimer set out within this Manual. This illustration is a proprietary component of the EIFS Practice Manual and is subject to full copyright protection."

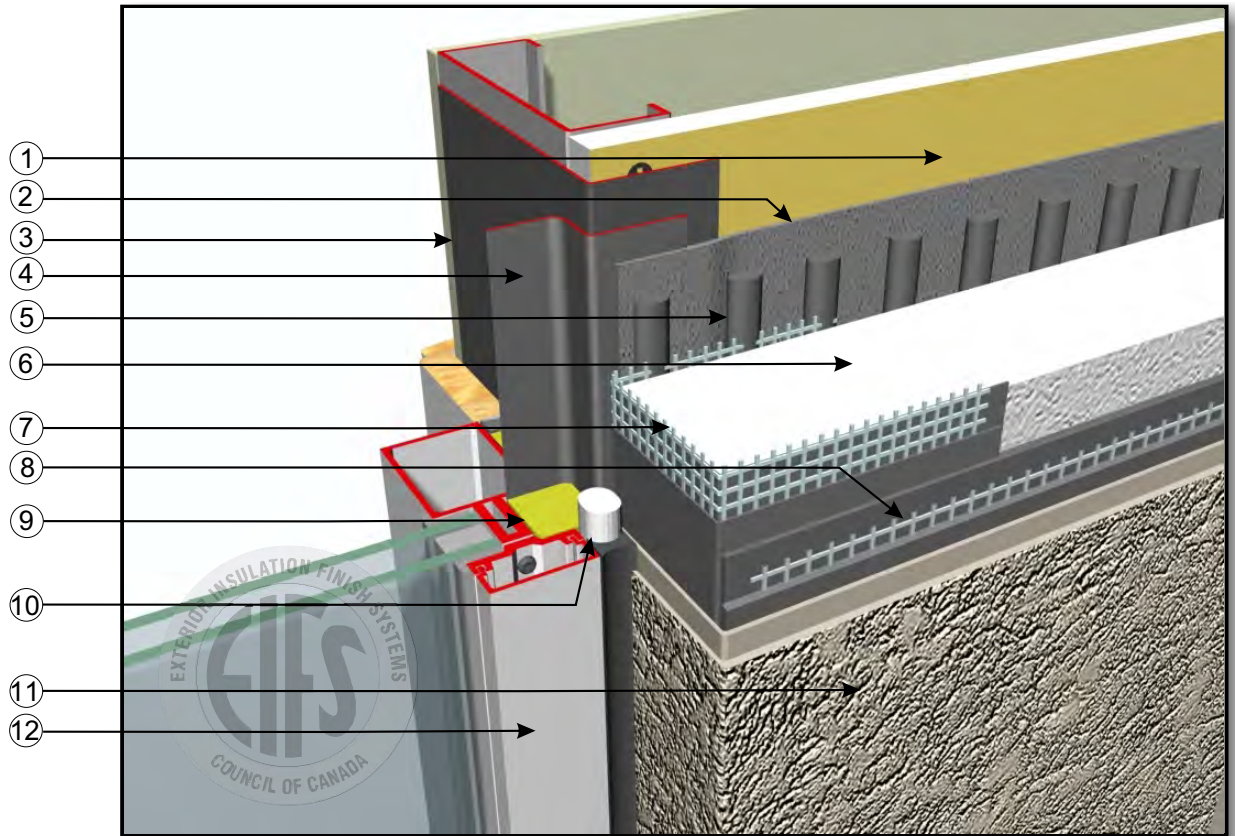

WINDOW JAMB

(TRANSITION “WRB” MATERIAL AT ROUGH OPENING AND TRANSITION MEMBRANE ONTO FRAME)

- ① Substrate
- ② Water Resistive Barrier
- ③ Transition Material, wrapped into window rough opening
- ④ Transition membrane wrapped onto window frame
- ⑤ Vertically Notched Adhesive or grooved insulation for drainage
- ⑥ Insulation Board
- ⑦ Back-wrapped insulation board
- ⑧ Reinforcing mesh embedded in Base Coat
- ⑨ Spray Foam
- ⑩ Backer Rod and Sealant. Sealant applied to base coat as per sealant manufacturer instructions
- ⑪ Finish Coat (over finish coat primer if specified)
- ⑫ Window Frame



DISCLAIMER:

Any user of this EIFS Practice Manual is expressly bound by the Waiver and Disclaimer set out within this Manual. This illustration is a proprietary component of the EIFS Practice Manual and is subject to full copyright protection."

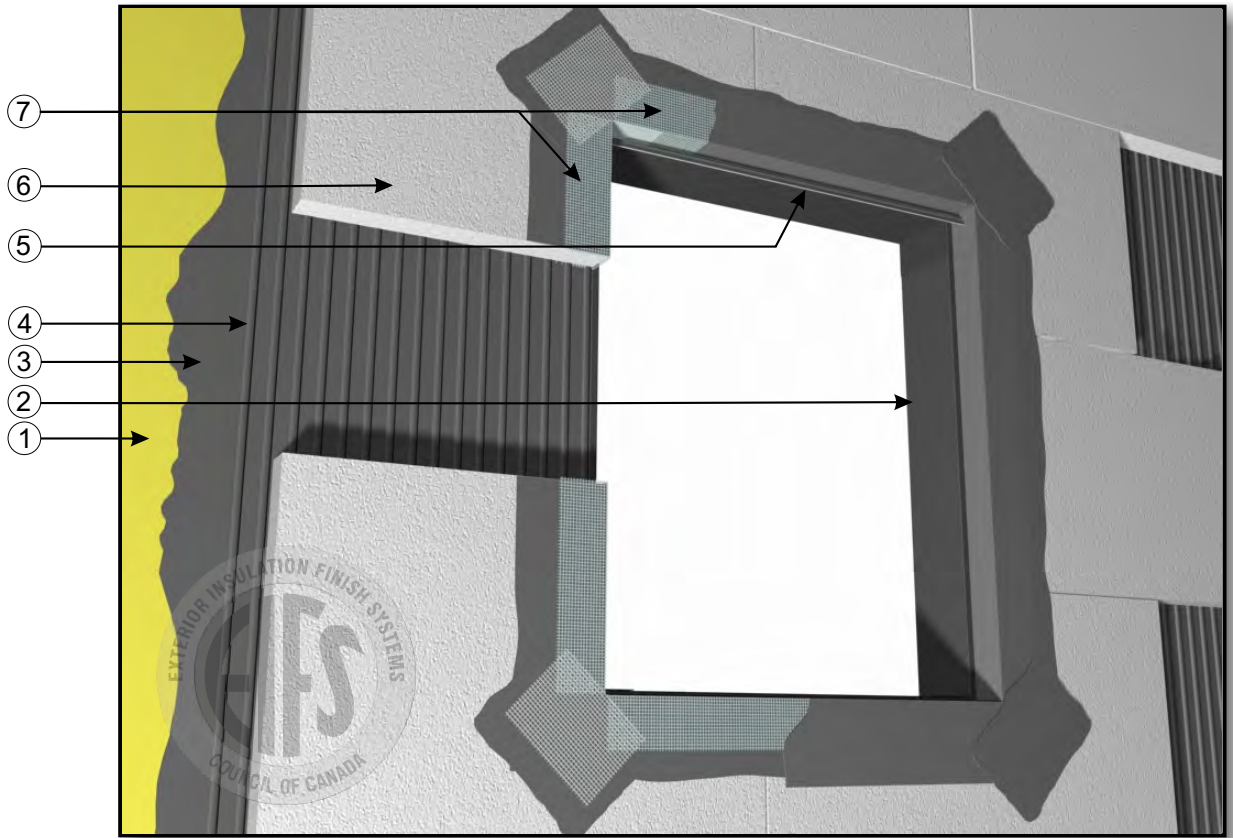

WINDOW OPENING TREATMENT

- ① Substrate
- ② Transition material wrapped into window rough opening
- ③ Water Resistant Barrier
- ④ Vertically Notched Adhesive or grooved insulation for drainage
- ⑤ Metal Flashing
- ⑥ Insulation Board
- ⑦ Back-wrapped insulation board with detail reinforcing mesh (apply 1st)
- ⑧ Inside corners using starter mesh (apply 2nd)
- ⑨ Reinforcing mesh at corners embedded in Base Coat (apply 3rd)

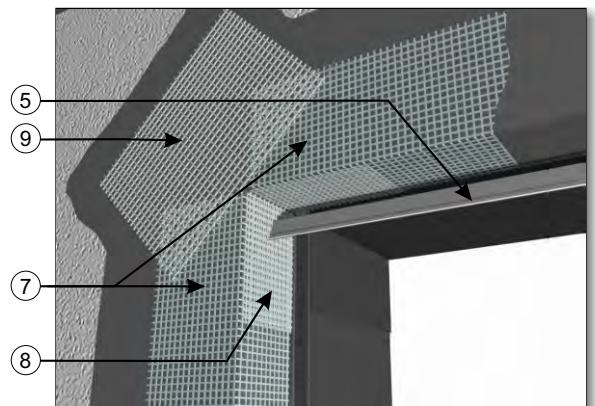

DISCLAIMER:

Any user of this EIFS Practice Manual is expressly bound by the Waiver and Disclaimer set out within this Manual. This illustration is a proprietary component of the EIFS Practice Manual and is subject to full copyright protection."

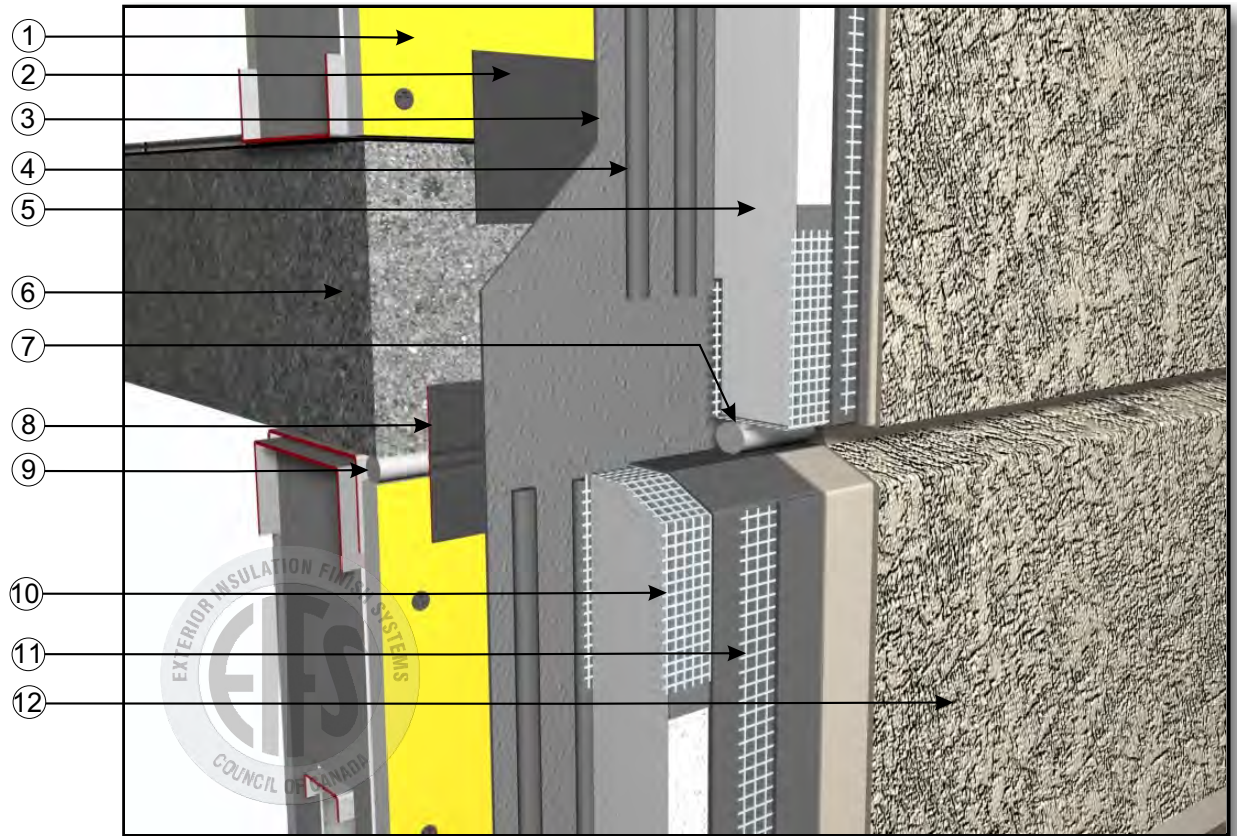

HORIZONTAL EXPANSION JOINT

- ① Substrate
- ② Transition material at joint
- ③ Water Resistant Barrier
- ④ Vertically Notched Adhesive or grooved insulation for drainage
- ⑤ Insulation Board
- ⑥ Floor Slab
- ⑦ Backer Rod and Sealant. Sealant applied to base coat as per sealant manufacturer instructions
- ⑧ Transition material at expansion joint in Substrate
- ⑨ Backer Rod at expansion joint
- ⑩ Pre-wrapped insulation board
- ⑪ Reinforcing mesh embedded in Base Coat
- ⑫ Finish Coat (over finish coat primer if specified)

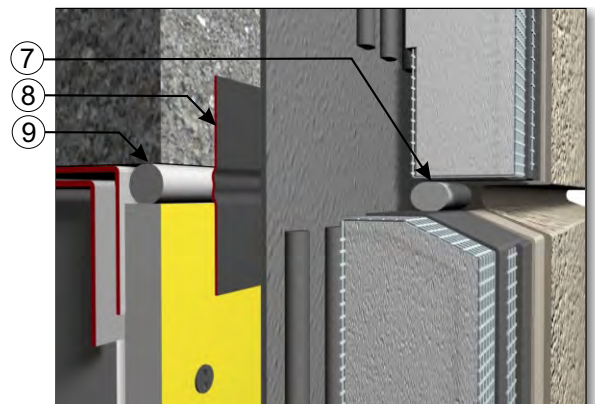

DISCLAIMER:

Any user of this EIFS Practice Manual is expressly bound by the Waiver and Disclaimer set out within this Manual. This illustration is a proprietary component of the EIFS Practice Manual and is subject to full copyright protection."

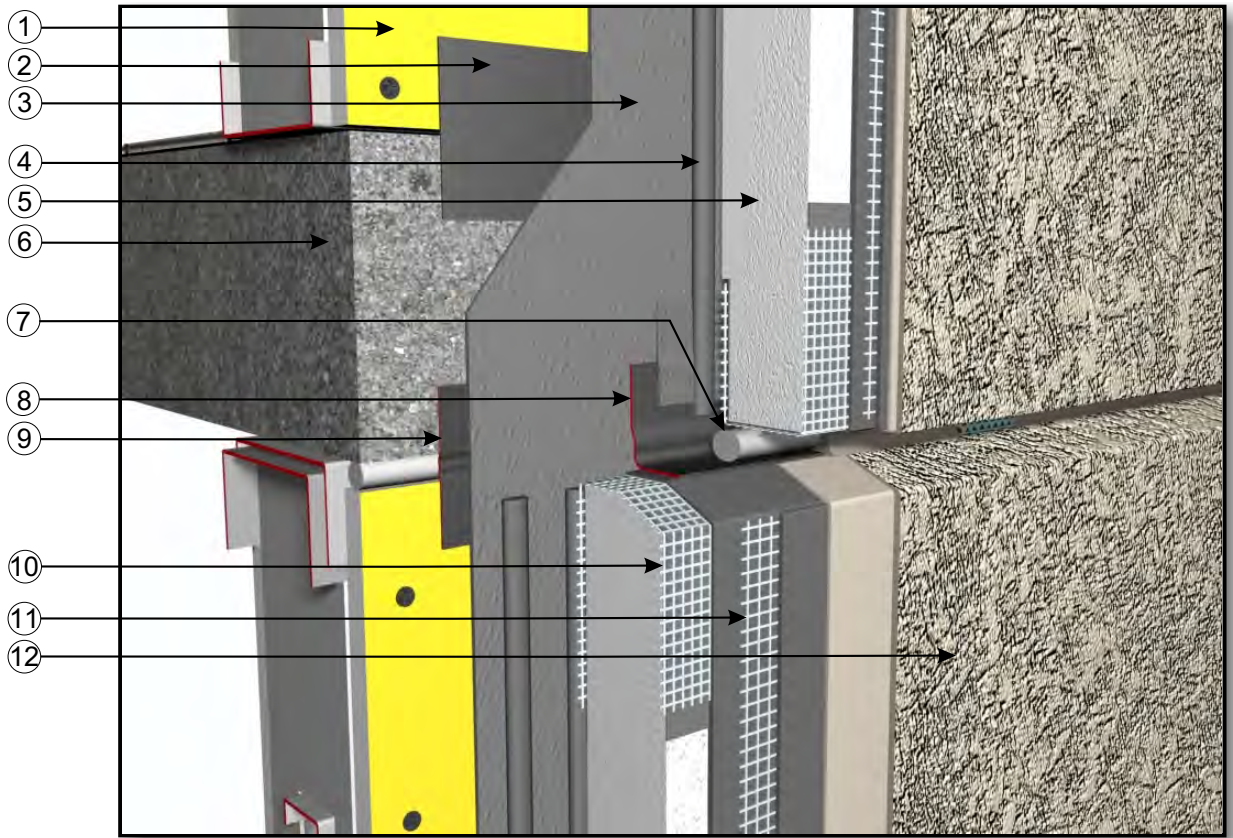

HORIZONTAL DRAINED EXPANSION JOINT

- ① Substrate
- ② Transition material at joint
- ③ Water Resistant Barrier
- ④ Vertically Notched Adhesive or grooved insulation for drainage
- ⑤ Insulation Board
- ⑥ Floor slab
- ⑦ Backer Rod and Sealant with drainage openings. Sealant applied to base coat as per sealant manufacturer instructions
- ⑧ Transition material to be applied from the face of the WRB and lapped onto the top of the insulation board at the bottom of joint
- ⑨ Backer Rod at expansion Joint
- ⑩ Back-wrapped insulation board at the bottom of the joint and pre-backwrapped at the top to allow for drainage
- ⑪ Reinforcing mesh embedded in Base Coat
- ⑫ Finish Coat (over finish coat primer if specified)

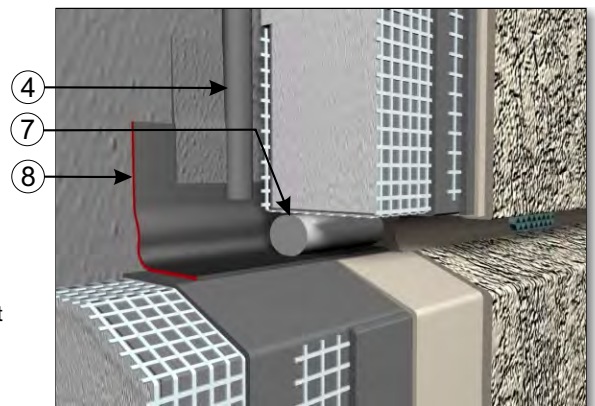

DISCLAIMER:

Any user of this EIFS Practice Manual is expressly bound by the Waiver and Disclaimer set out within this Manual. This illustration is a proprietary component of the EIFS Practice Manual and is subject to full copyright protection."

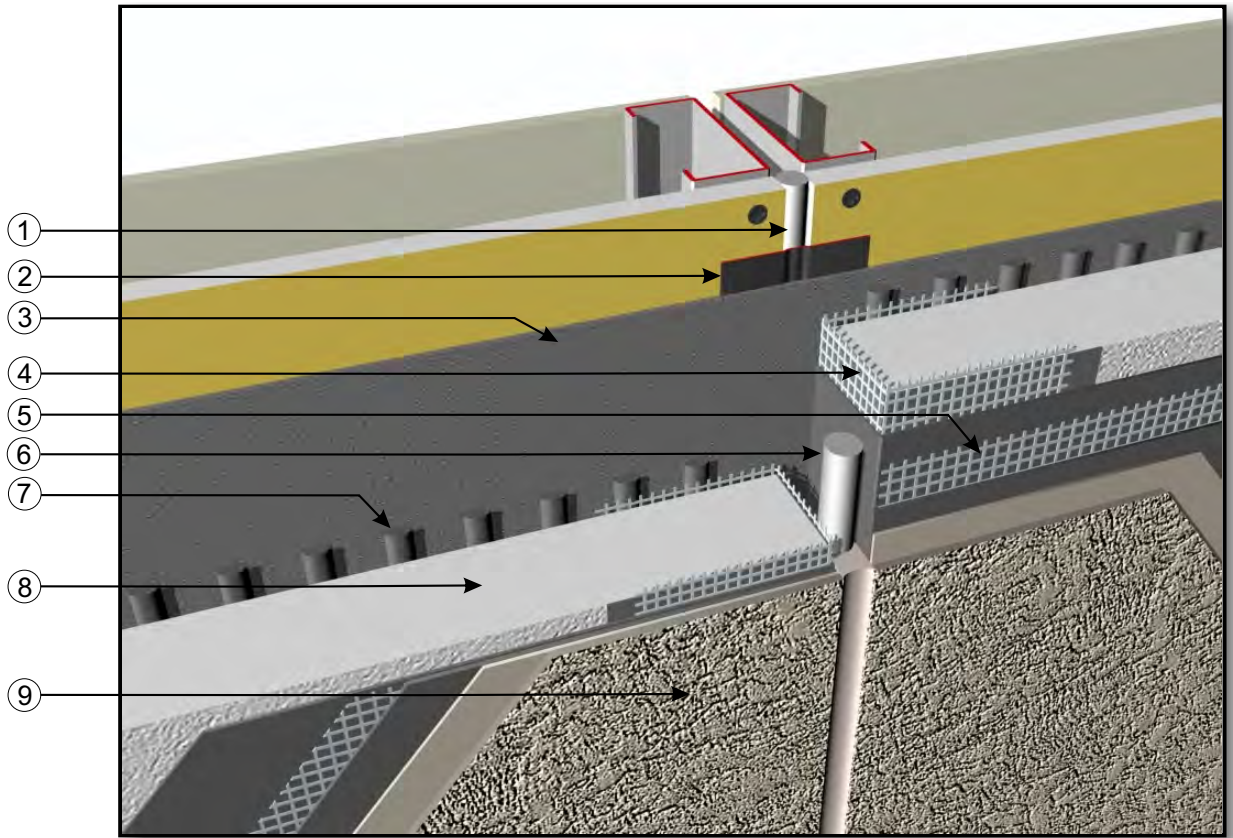

VERTICAL EXPANSION JOINT

- ① Backer Rod at expansion joint
- ② Transition material
- ③ Water Resistive Barrier
- ④ Back-wrapped insulation board (Pre-wrapped preferred)
- ⑤ Reinforcing mesh embedded in Base Coat
- ⑥ Backer Rod and Sealant. Sealant applied to base coat as per sealant manufacturer instructions
- ⑦ Vertically Notched Adhesive or grooved insulation
- ⑧ Insulation Board
- ⑧ Finish Coat (over finish coat primer if specified)

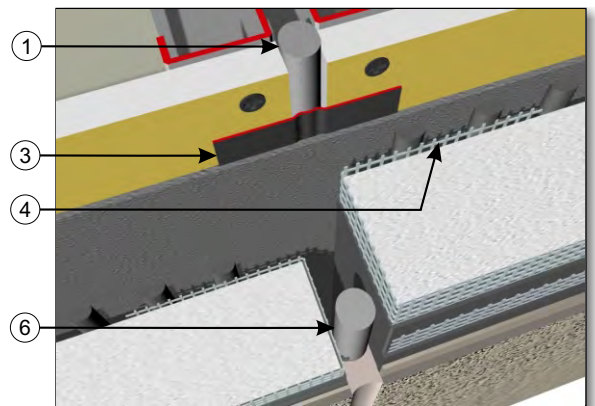

DISCLAIMER:

Any user of this EIFS Practice Manual is expressly bound by the Waiver and Disclaimer set out within this Manual. This illustration is a proprietary component of the EIFS Practice Manual and is subject to full copyright protection."

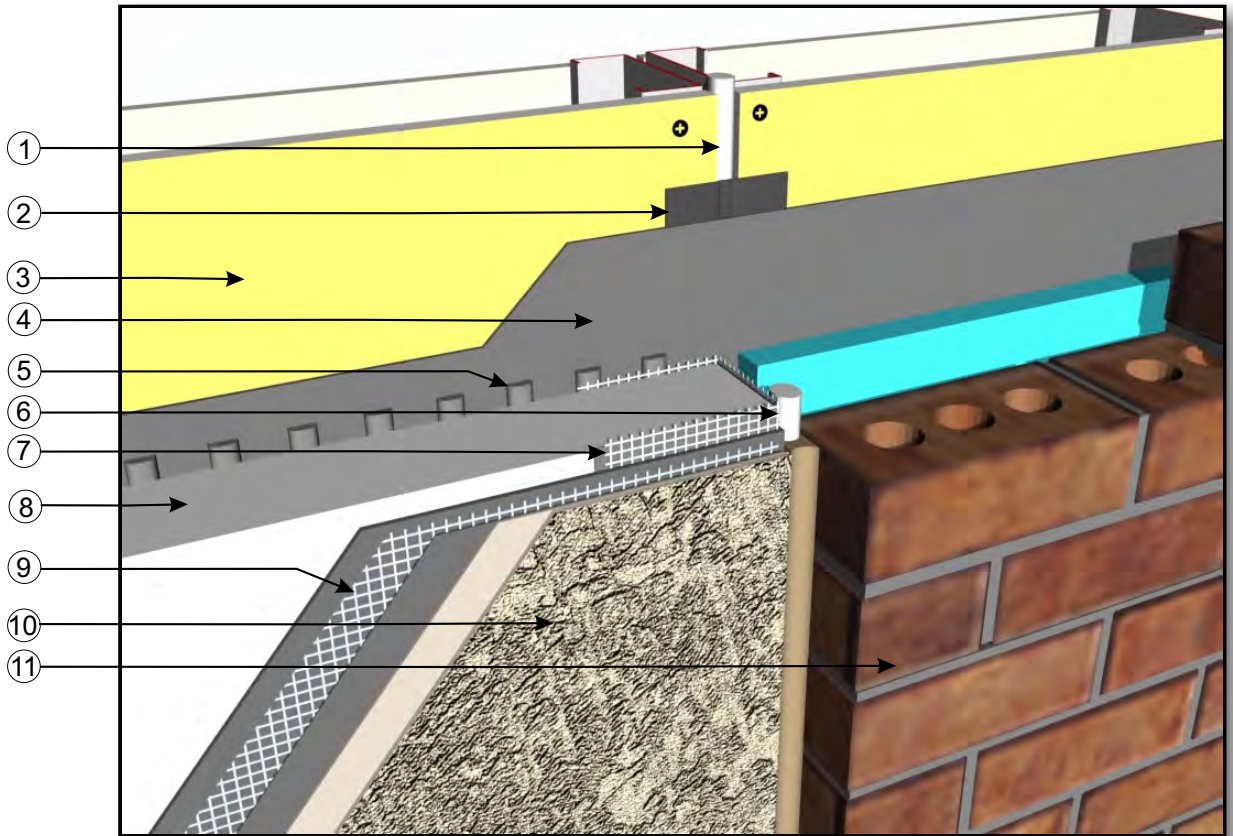

VERTICAL EXPANSION JOINT AT DISSIMILAR CLADDING

- ① Backer Rod at expansion joint
- ② Transition material
- ③ Substrate
- ④ Water Resistive Barrier
- ⑤ Vertically Notched Adhesive or grooved insulation for drainage
- ⑥ Backer Rod and Sealant, Sealant applied to base coat as per sealant manufacturer instructions
- ⑦ Back-wrapped insulation board (Pre-wrapped preferred)
- ⑧ Insulation Board
- ⑨ Reinforcing mesh embedded in Base Coat
- ⑩ Finish Coat (over finish coat primer if specified)
- ⑪ Dissimilar Cladding

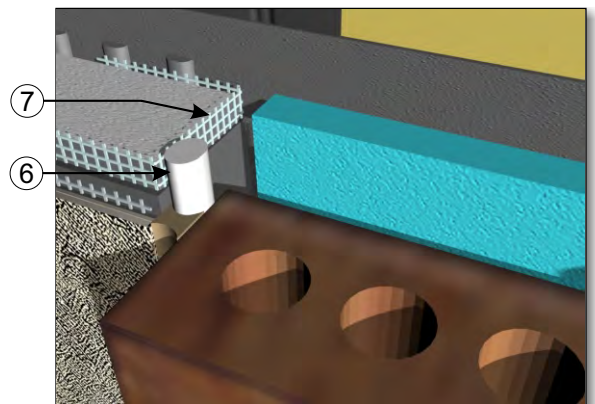

DISCLAIMER:

Any user of this EIFS Practice Manual is expressly bound by the Waiver and Disclaimer set out within this Manual. This illustration is a proprietary component of the EIFS Practice Manual and is subject to full copyright protection."

EIFS

EXTERIOR INSULATION FINISH SYSTEMS

EIFS COUNCIL OF CANADA

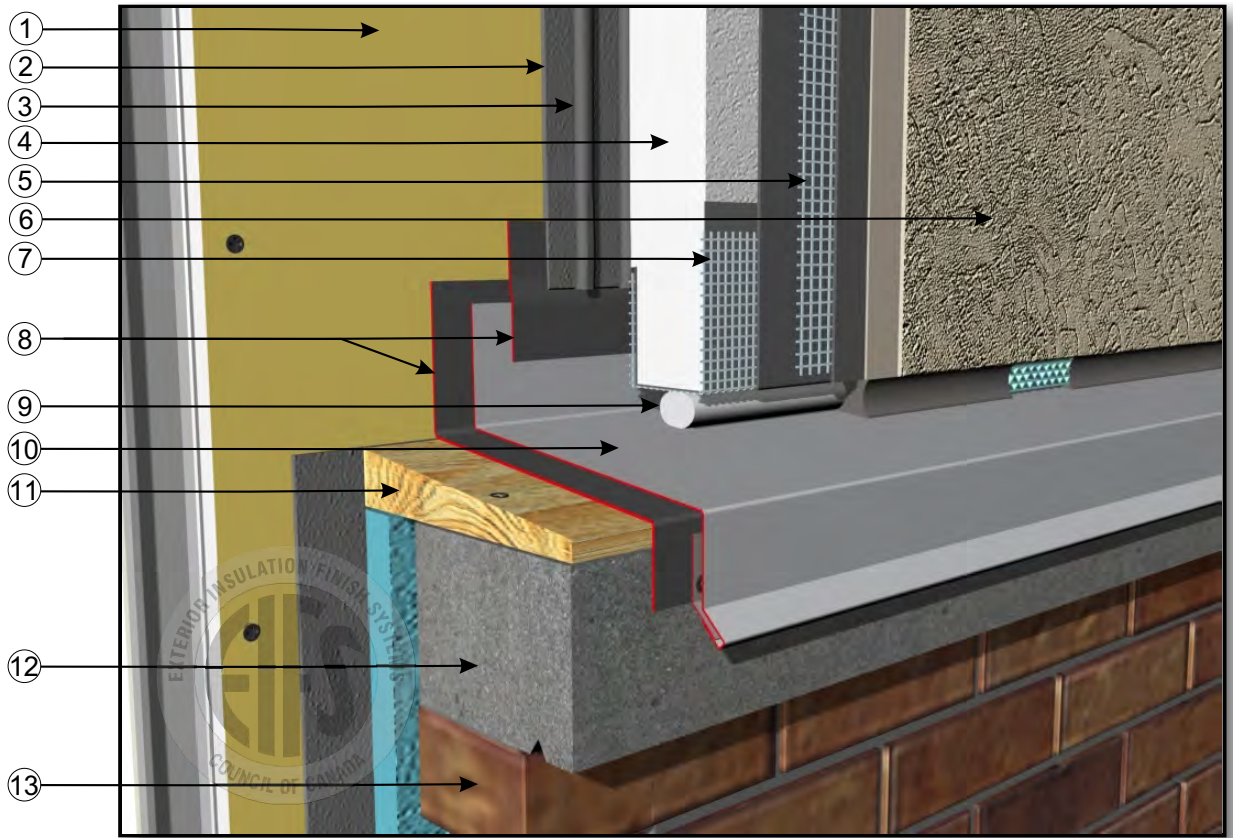

TERMINATION ABOVE DISSIMILAR CLADDING

- ① Substrate
- ② Water Resistant Barrier
- ③ Vertically Notched Adhesive or grooved insulation for drainage
- ④ Insulation Board
- ⑤ Reinforcing mesh embedded in Base Coat
- ⑥ Finish Coat (over finish coat primer if specified)
- ⑦ Pre-wrapped insulation board to allow for drainage
- ⑧ Transition material
- ⑨ Backer Rod and Sealant with drainage openings. Sealant applied to base coat as per sealant manufacturer instructions
- ⑩ Metal Flashing
- ⑪ Sloped Wood Blocking
- ⑫ Concrete Sill
- ⑬ Dissimilar Cladding

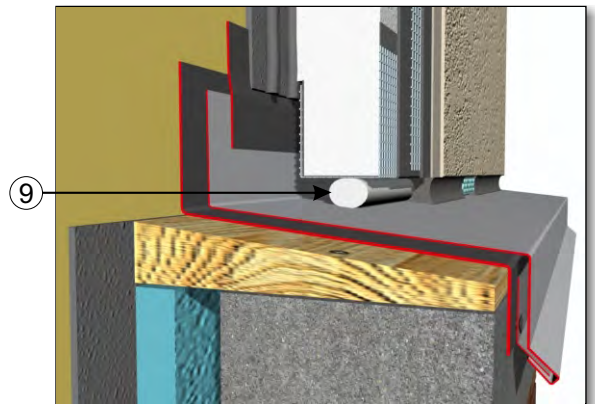

EIFS
COUNCIL
OF
CANADA
www.eifscouncil.org

DISCLAIMER:

Any user of this EIFS Practice Manual is expressly bound by the Waiver and Disclaimer set out within this Manual. This illustration is a proprietary component of the EIFS Practice Manual and is subject to full copyright protection."

ECC R & D

Last revise: Feb 15/13

Issued: Dec 2012

14-25

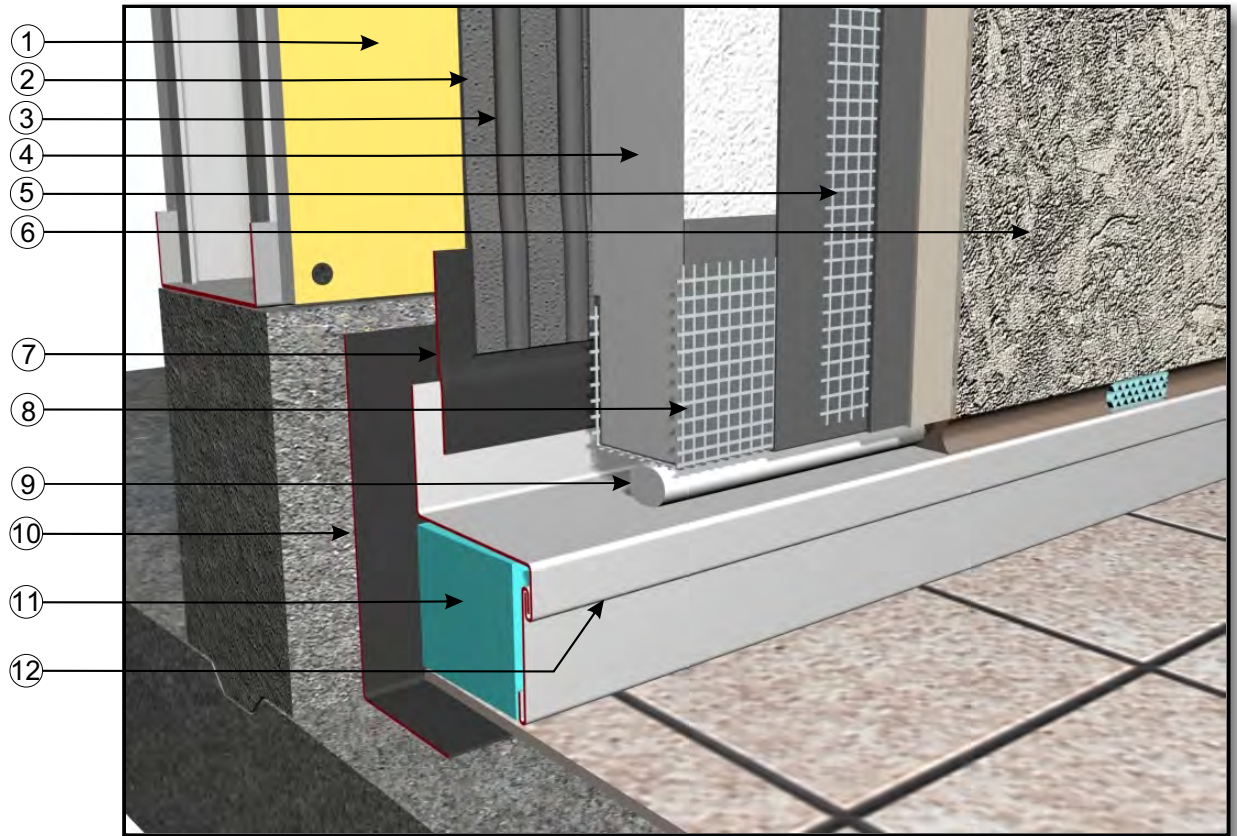

TERMINATION AT BALCONY (ABOVE SLAB)

- ① Substrate
- ② Water Resistive Barrier
- ③ Vertically Notched Adhesive or grooved insulation for drainage
- ④ Insulation Board
- ⑤ Reinforcing Mesh embedded in Base Coat
- ⑥ Finish Coat (over finish coat primer if specified)
- ⑦ Transition material covering Flashing
- ⑧ Back-wrapped insulation board (pre-wrapped preferred) to allow for drainage
- ⑨ Backer Rod and Sealant with drainage openings. Sealant applied to base coat as per sealant manufacturer instruction
- ⑩ Waterproofing Membrane
- ⑪ Rigid Insulation
- ⑫ Two piece Metal Flashing (to allow future waterproofing)

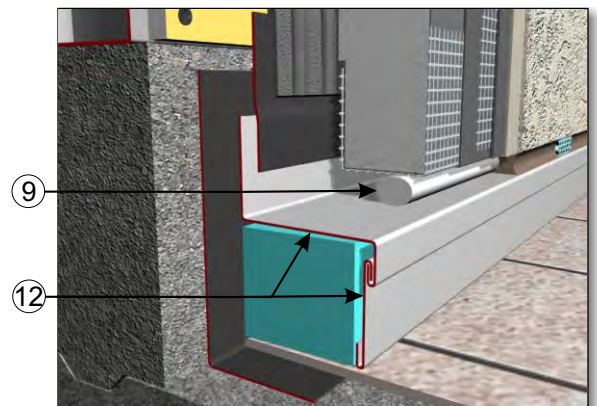

DISCLAIMER:

Any user of this EIFS Practice Manual is expressly bound by the Waiver and Disclaimer set out within this Manual. This illustration is a proprietary component of the EIFS Practice Manual and is subject to full copyright protection."

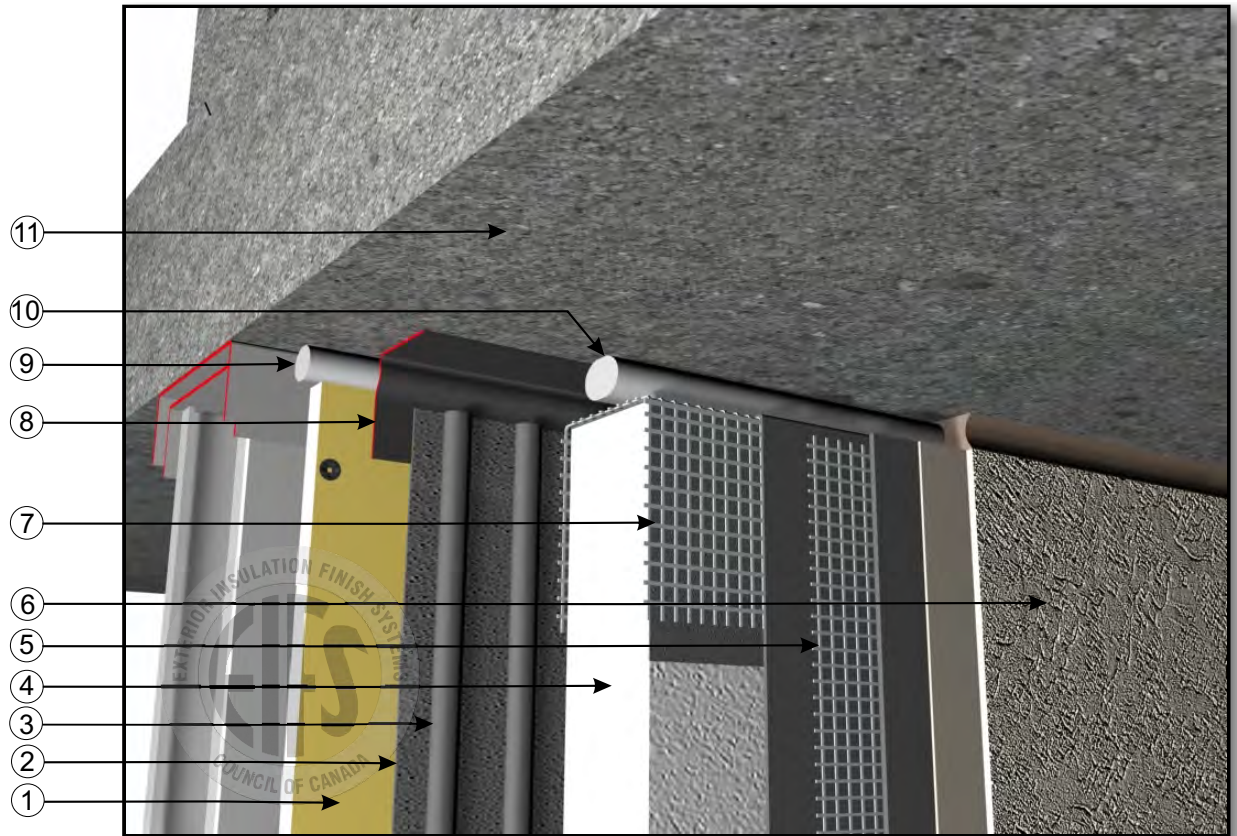

TERMINATION AT BALCONY (BELOW SLAB)

- ① Substrate
- ② Water Resistive Barrier
- ③ Vertically Notched Adhesive or grooved insulation for drainage
- ④ Insulation Board
- ⑤ Reinforcing mesh embedded in Base Coat
- ⑥ Finish Coat (over finish coat primer if specified)
- ⑦ Pre-wrapped insulation board
- ⑧ Transition material
- ⑨ Backer Rod between slab and substrate top edge
- ⑩ Backer Rod and Sealant with drainage openings. Sealant applied to base coat as per sealant manufacturer instruction
- ⑪ Balcony Slab

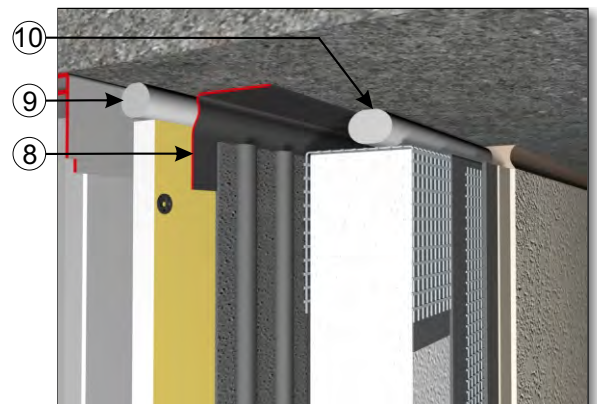

DISCLAIMER:

Any user of this EIFS Practice Manual is expressly bound by the Waiver and Disclaimer set out within this Manual. This illustration is a proprietary component of the EIFS Practice Manual and is subject to full copyright protection."

EIFS

EXTERIOR INSULATION FINISH SYSTEMS

EIFS COUNCIL OF CANADA

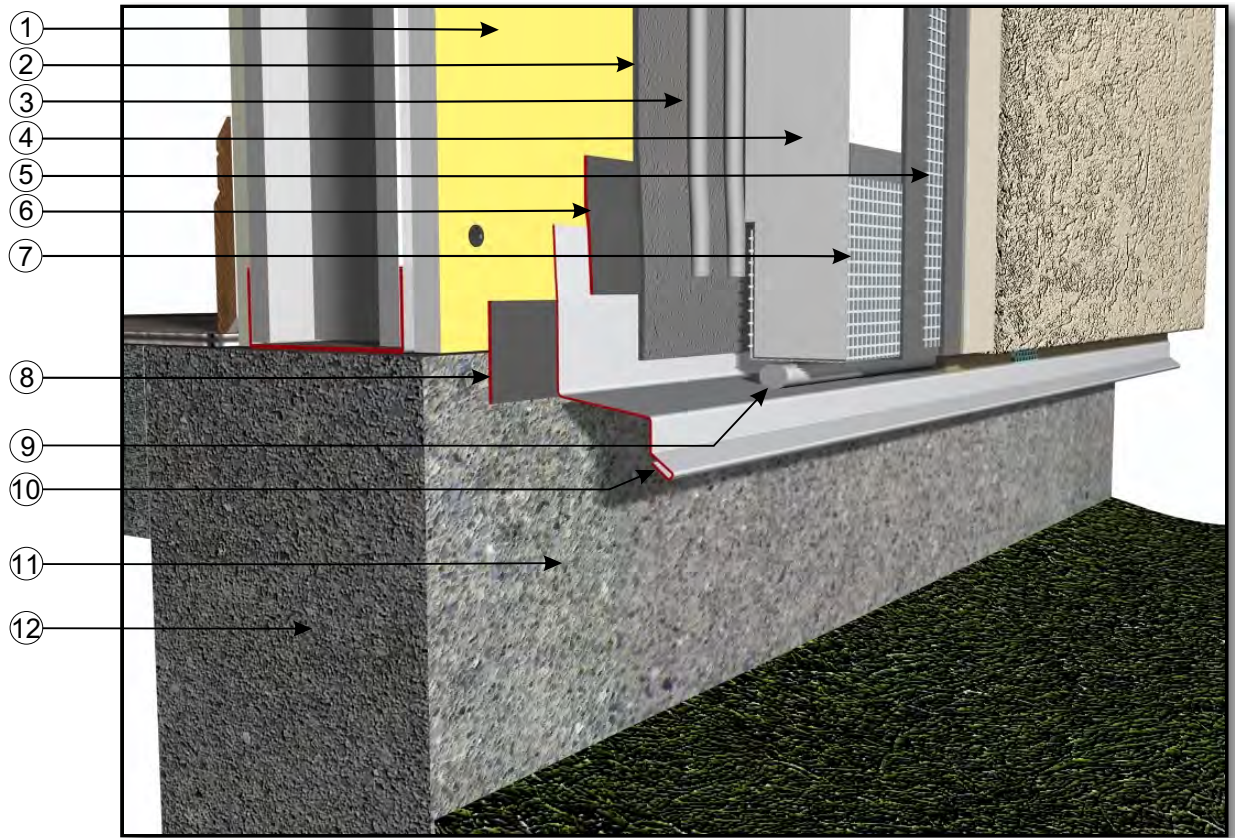

TERMINATION AT GRADE

- ① Substrate
- ② Water Resistive Barrier
- ③ Vertically Notched Adhesive or grooved insulation for drainage
- ④ Insulation Board
- ⑤ Reinforcing mesh embedded in Base Coat
- ⑥ Transition material covering Flashing
- ⑦ Back-wrapped insulation board (pre-wrapped preferred)
- ⑧ Transition material covering joint
- ⑨ Backer Rod and Sealant with drainage openings. Sealant applied to base coat as per sealant manufacturer instructions
- ⑩ Metal Flashing (sloped)
- ⑪ Clearance required as per specification
- ⑫ Foundation

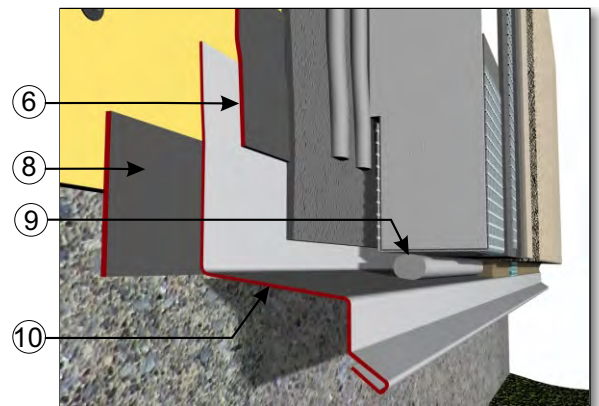

**EIFS
COUNCIL
OF
CANADA**
www.eifscouncil.org

DISCLAIMER:

Any user of this EIFS Practice Manual is expressly bound by the Waiver and Disclaimer set out within this Manual. This illustration is a proprietary component of the EIFS Practice Manual and is subject to full copyright protection."

ECC R & D

Last revise: Feb 15/13

Issued: Dec 2012

17-25

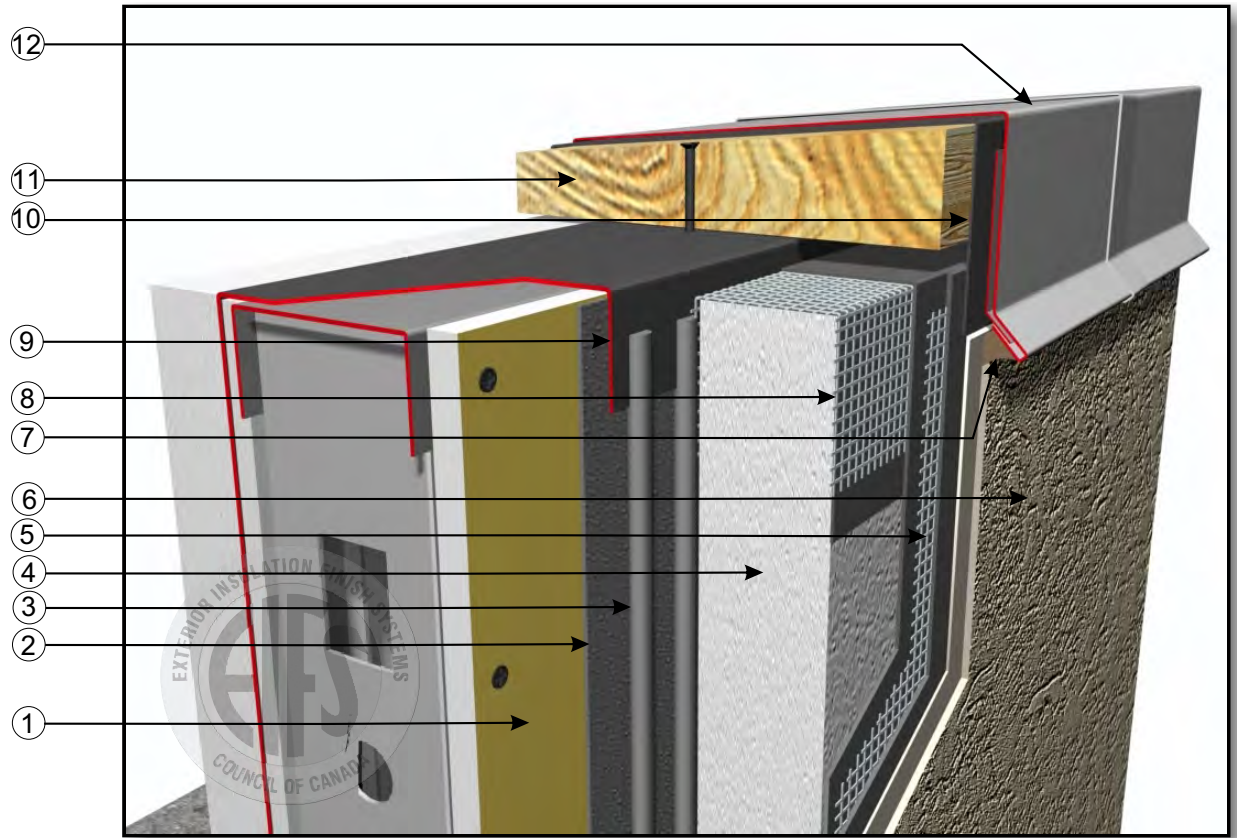

ROOF TOP PARAPET

- ① Substrate
- ② Water Resistant Barrier
- ③ Vertically Notched Adhesive or grooved insulation for drainage
- ④ Insulation Board
- ⑤ Reinforcing mesh embedded in Base Coat
- ⑥ Finish Coat (over finish coat primer if specified)
- ⑦ Sealant under Flashing (optional), Sealant applied to base coat as per sealant manufacturer instructions
- ⑧ Pre-wrapped insulation board
- ⑨ Transition Membrane
- ⑩ Waterproofing Membrane covering wood blocking
- ⑪ Sloped wood blocking
- ⑫ Sheet Metal Cap Flashing
- ⑬ Gap between wood blocking and EIFS
- ⑭ Gap in sealant at flashing joint

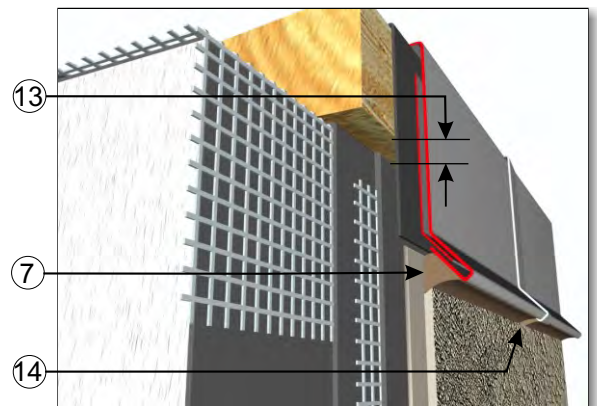

DISCLAIMER:

Any user of this EIFS Practice Manual is expressly bound by the Waiver and Disclaimer set out within this Manual. This illustration is a proprietary component of the EIFS Practice Manual and is subject to full copyright protection."

EIFS

EXTERIOR INSULATION FINISH SYSTEMS

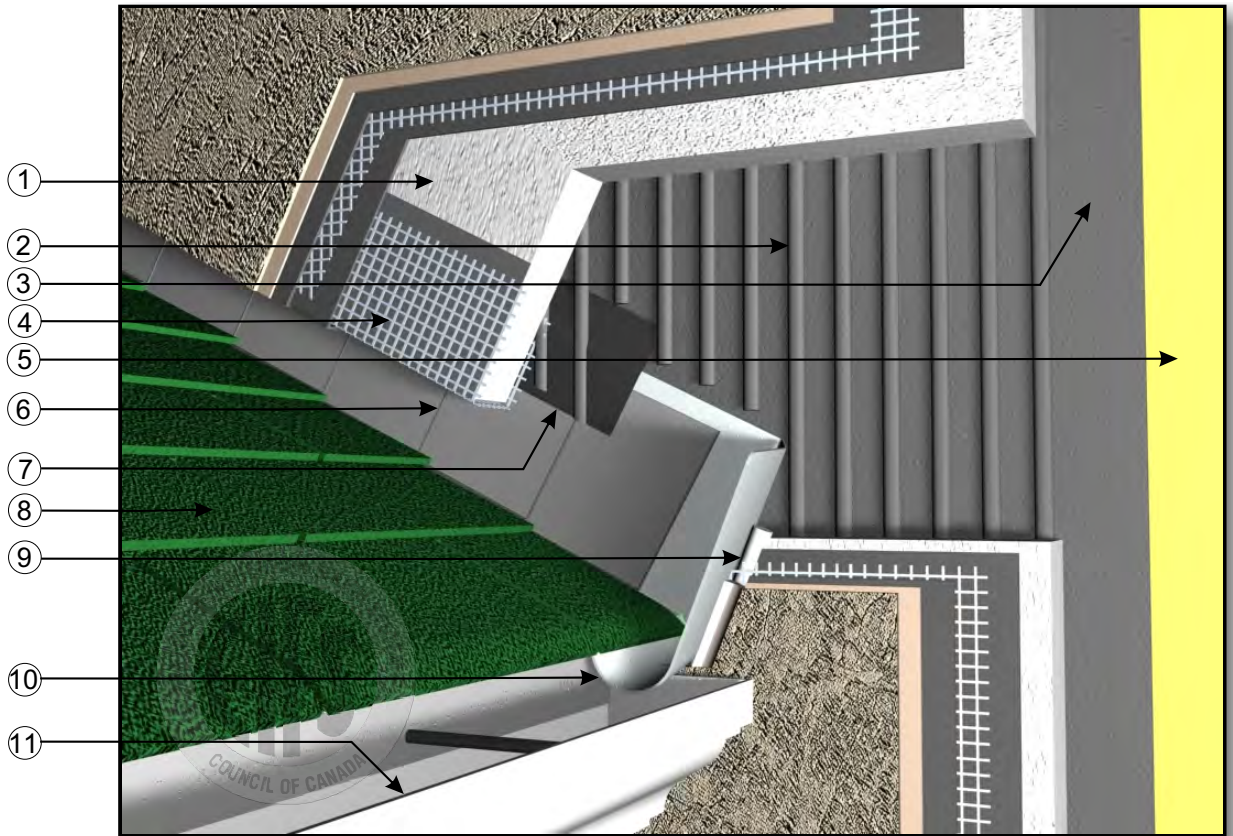

KICK-OUT FLASHING

- ① Insulation Board
- ② Vertically Notched Adhesive or grooved insulation for drainage
- ③ Water Resistant Barrier
- ④ Pre-wrapped insulation board to allow for drainage
- ⑤ Substrate
- ⑥ Step Flashing
- ⑦ Transition material covering step flashing
- ⑧ Roof Shingles
- ⑨ Backer Rod and Sealant around Kick-out Flashing. Sealant applied to base coat as per sealant manufacturer instructions
- ⑩ Kick-out Flashing
- ⑪ Gutter

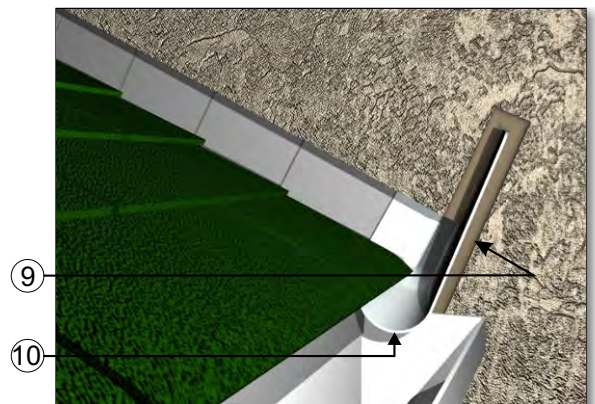

DISCLAIMER:

Any user of this EIFS Practice Manual is expressly bound by the Waiver and Disclaimer set out within this Manual. This illustration is a proprietary component of the EIFS Practice Manual and is subject to full copyright protection."

EIFS

EXTERIOR INSULATION FINISH SYSTEMS

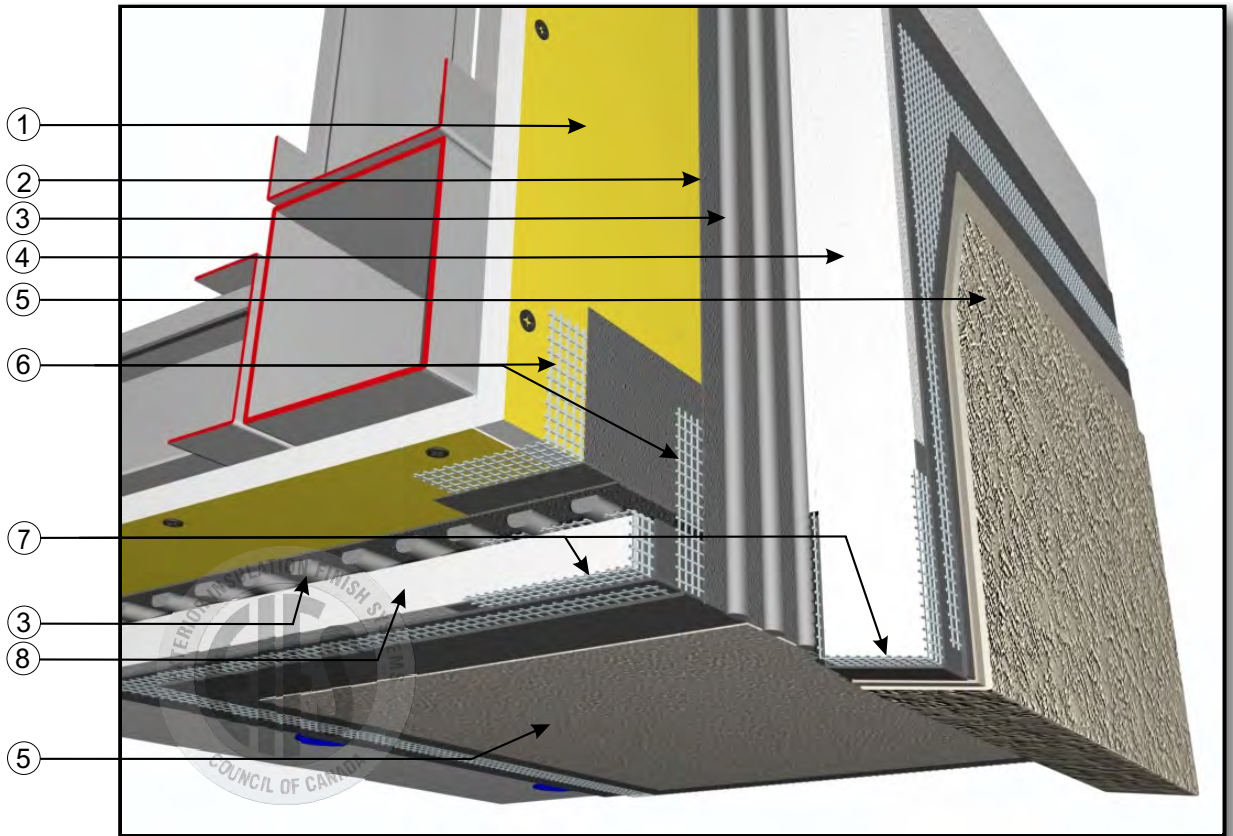

TERMINATION AT SOFFIT

- ① Substrate
- ② Water Resistive Barrier
- ③ Vertically Notched Adhesive or grooved insulation board
- ④ Insulation board
- ⑤ Finish Coat (over finish coat primer if specified)
- ⑥ Joint Treatment/transition material
- ⑦ Pre-wrapped insulation board to allow for drainage
- ⑧ Mechanically fastened insulation board at soffit
- ⑨ **NOTE:** EIFS to extend past soffit to create drip (slope)
- ⑩ Moisture drainage through notched adhesive ribbons

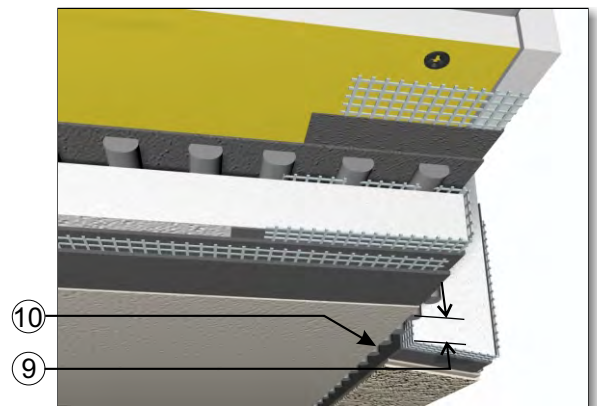

DISCLAIMER:

Any user of this EIFS Practice Manual is expressly bound by the Waiver and Disclaimer set out within this Manual. This illustration is a proprietary component of the EIFS Practice Manual and is subject to full copyright protection."

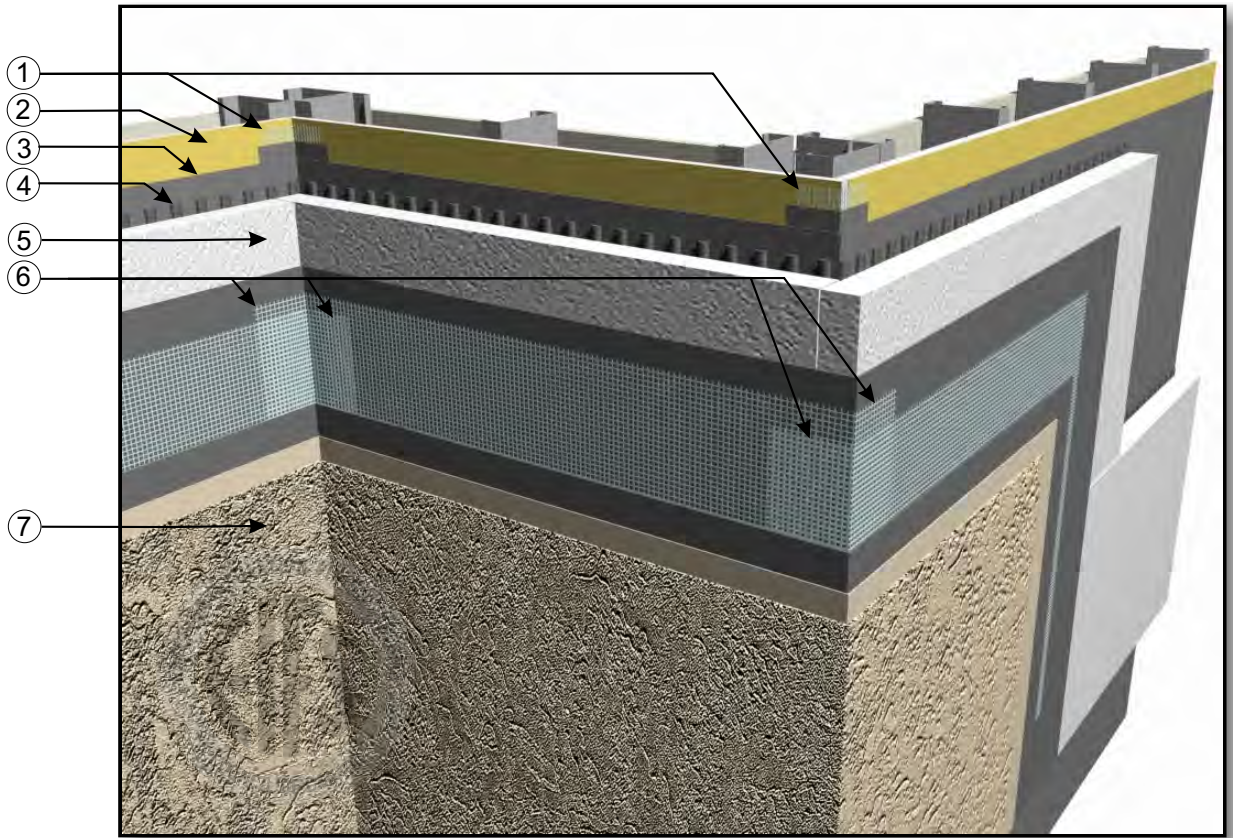

CORNER TREATMENT

- ① Joint treatment/transition material
- ② Substrate
- ③ Water Resistant Barrier
- ④ Vertically Notched Adhesive or grooved insulation board
- ⑤ Insulation Board
- ⑥ Reinforcing Mesh embedded in Base Coat (overlapping on both sides of corner)
- ⑦ Finish Coat (over finish coat primer if specified)
- ⑧ Insulation Board interlocking pattern at corners

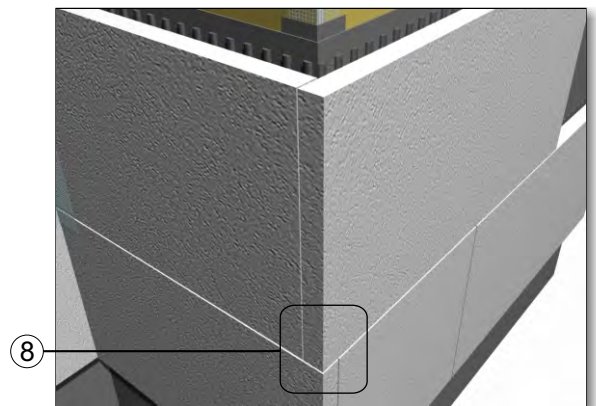

DISCLAIMER:

Any user of this EIFS Practice Manual is expressly bound by the Waiver and Disclaimer set out within this Manual. This illustration is a proprietary component of the EIFS Practice Manual and is subject to full copyright protection."

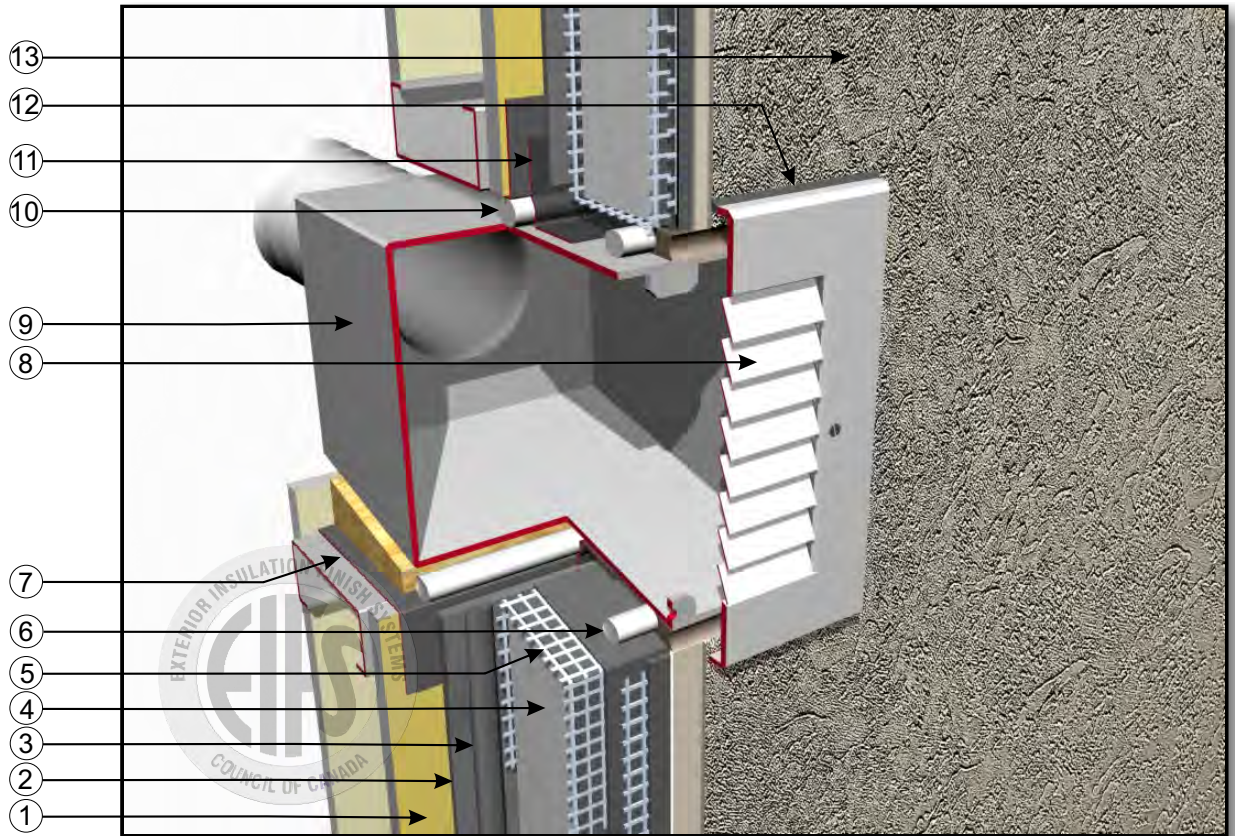

EXHAUST PENETRATION INTO WALL

- ① Substrate
- ② Water Resistive Barrier
- ③ Vertically Notched Adhesive or grooved insulation board
- ④ Insulation Board
- ⑤ Back-wrapped Insulation Board
- ⑥ Backer Rod and Sealant with drainage at bottom. Sealant applied to base coat as per sealant manufacturer instructions
- ⑦ Transition material wrapped into rough opening
- ⑧ Exhaust Grill
- ⑨ Sheet Metal Exhaust Box with sealed joints
- ⑩ Backer Rod around the wall opening
- ⑪ Transition material covering Backer Rod
- ⑫ Perimeter Sealant except bottom for drainage. Sealant applied to base coat as per sealant manufacturer instructions.
- ⑬ Finish Coat (over finish coat primer if specified)

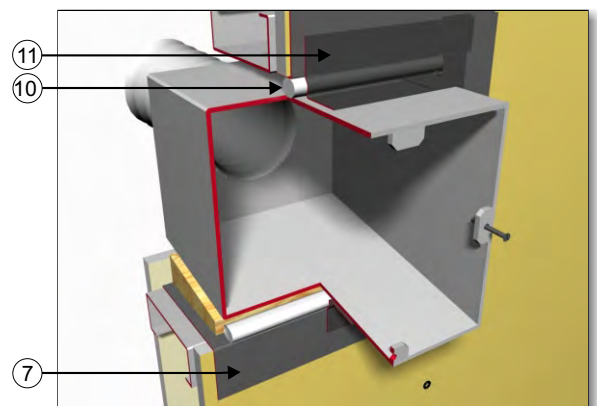

DISCLAIMER:

Any user of this EIFS Practice Manual is expressly bound by the Waiver and Disclaimer set out within this Manual. This illustration is a proprietary component of the EIFS Practice Manual and is subject to full copyright protection."

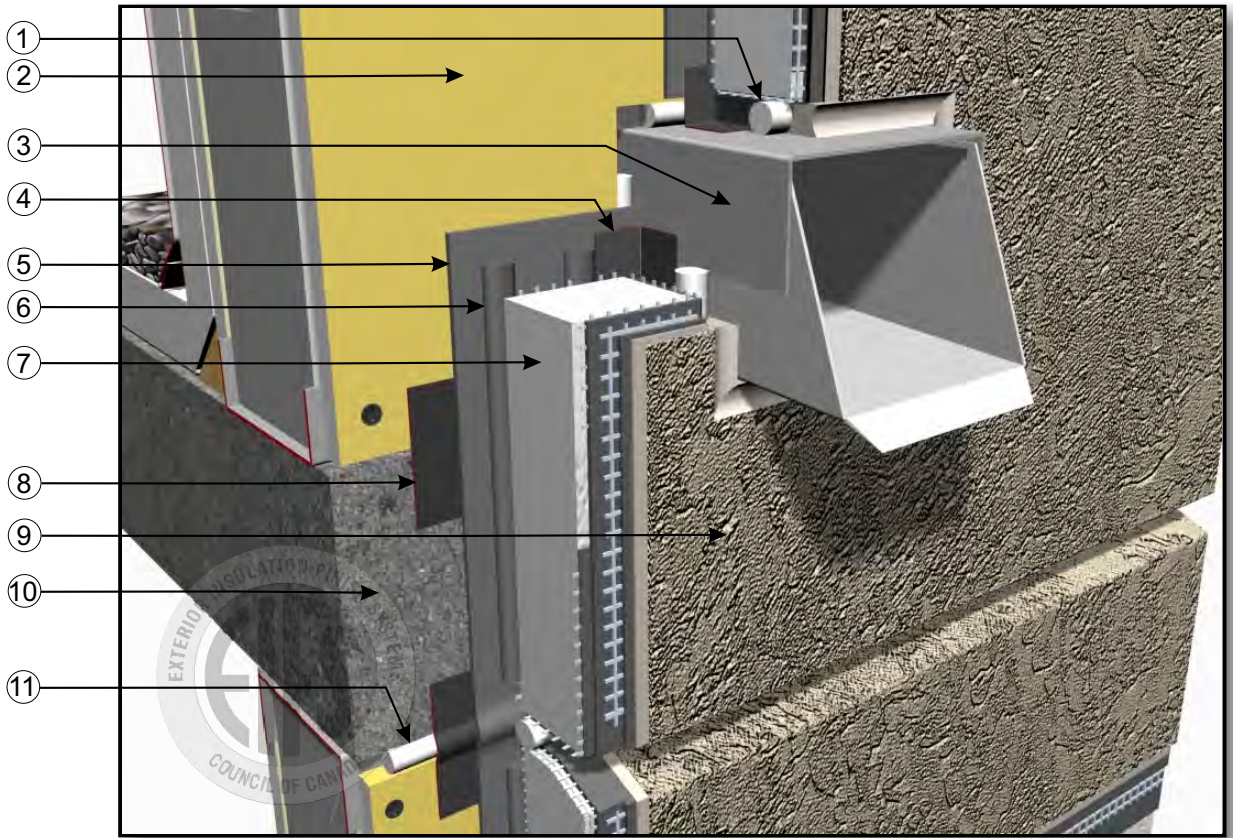

SCUPPER PENETRATION INTO WALL

- ① Backer Road and Sealant. Sealant applied to base coat as per sealant manufacturer instructions
- ② Substrate
- ③ Scupper assembly
- ④ Transition material all around the perimeter of the Scupper
- ⑤ Water Resistant Barrier
- ⑥ Vertically Notched Adhesive or grooved insulation board
- ⑦ Insulation Board
- ⑧ Transition material at joint
- ⑨ Finish Coat (over finish coat primer if specified)
- ⑩ Roof slab
- ⑪ Expansion Joint at underside of roof slab

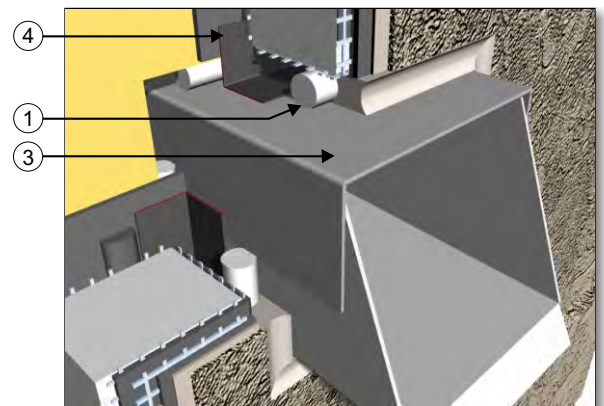

DISCLAIMER:

Any user of this EIFS Practice Manual is expressly bound by the Waiver and Disclaimer set out within this Manual. This illustration is a proprietary component of the EIFS Practice Manual and is subject to full copyright protection."

EIFS

EXTERIOR INSULATION FINISH SYSTEMS

EIFS COUNCIL OF CANADA

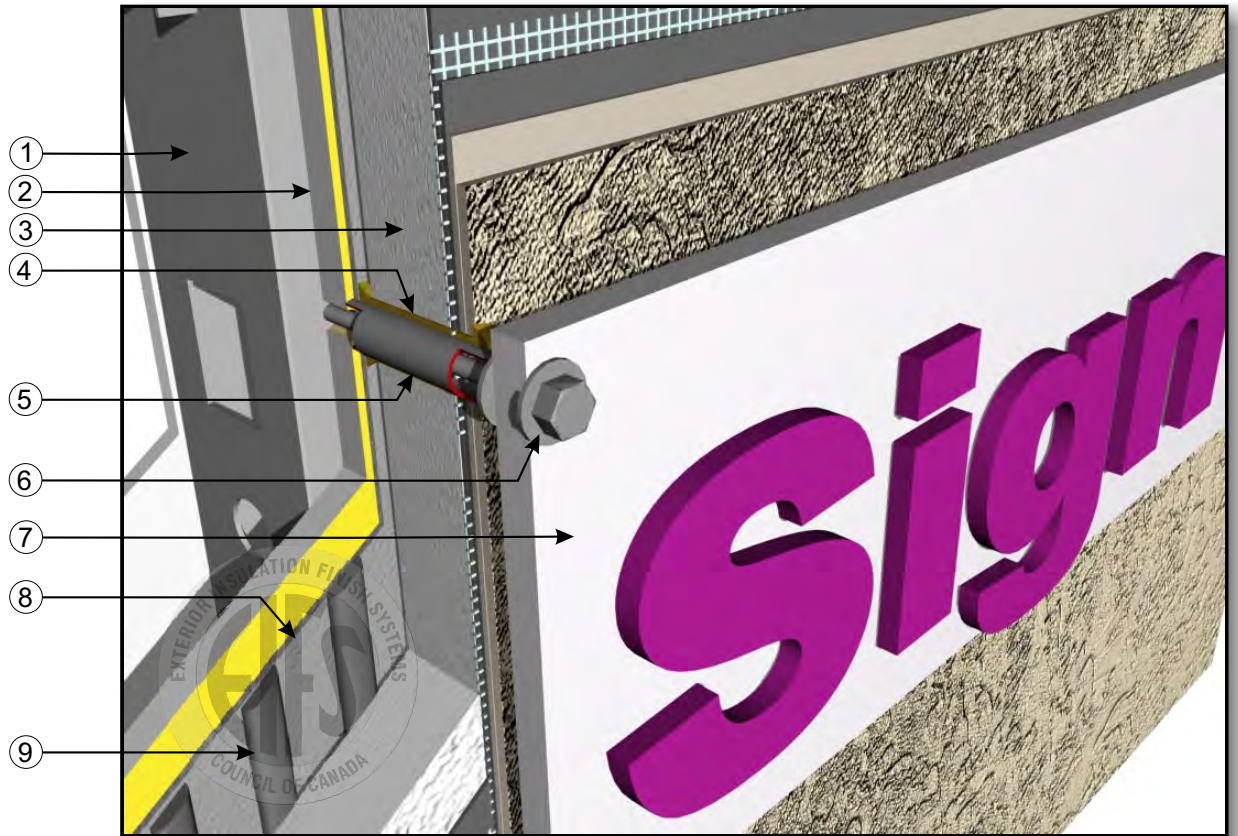

SIGNAGE ATTACHMENT

- ① Steel Stud Framing
- ② Substrate
- ③ Insulation Board
- ④ Neutral Cure Sealant
- ⑤ Stainless Steel Pipe Sleeve filled with sealant
- ⑥ Stainless Steel Fastener
- ⑦ Signage
- ⑧ Water Resistive Barrier
- ⑨ Vertically Notched Adhesive or grooved insulation board

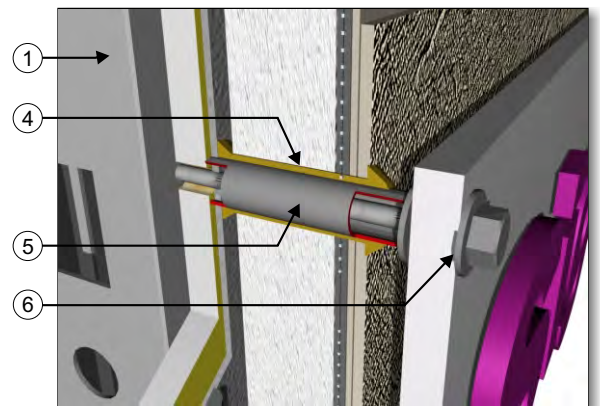

EIFS
COUNCIL
OF
CANADA
www.eifscouncil.org

DISCLAIMER:

Any user of this EIFS Practice Manual is expressly bound by the Waiver and Disclaimer set out within this Manual. This illustration is a proprietary component of the EIFS Practice Manual and is subject to full copyright protection."

ECC R & D

Last revise: Feb 15/13

Issued: Jan 2012

24-25

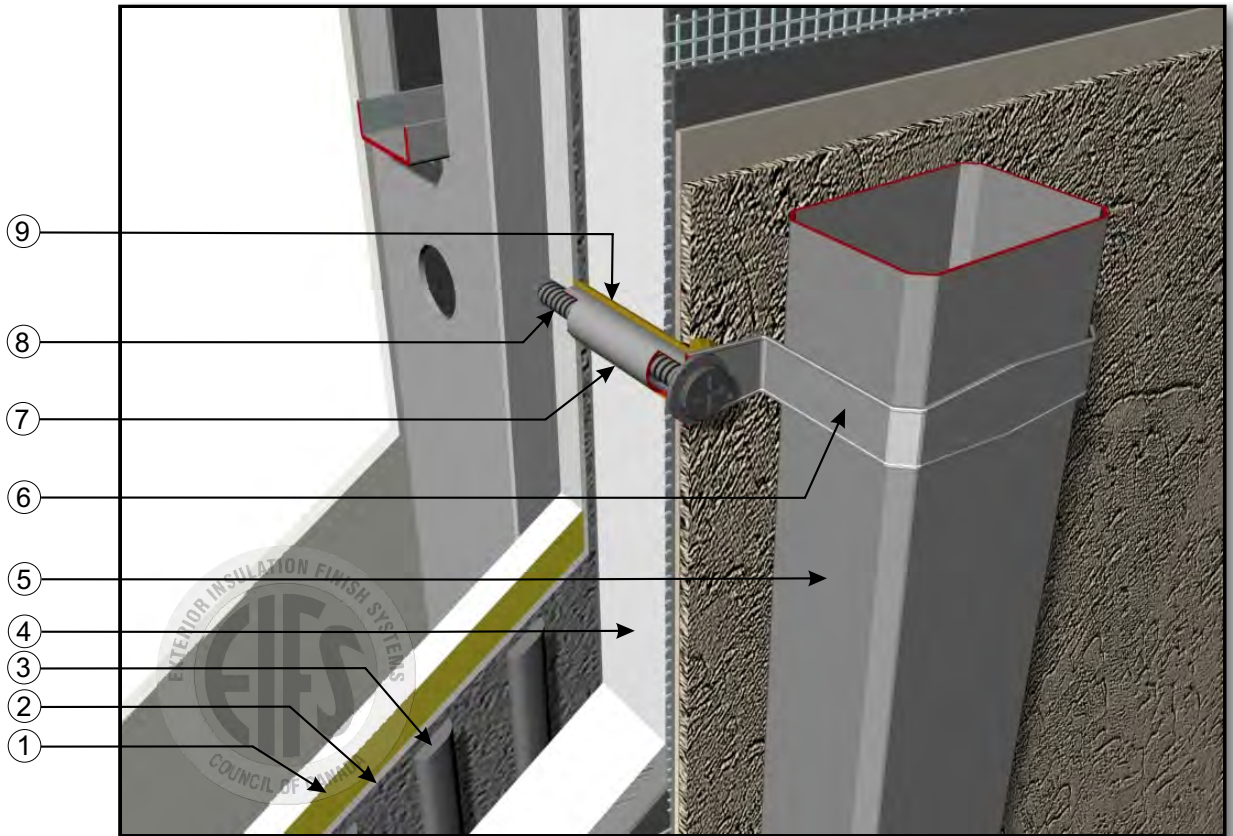

RAIN WATER LEADER ATTACHMENT

- ① Substrate
- ② Water Resistant Barrier
- ③ Vertically Notched Adhesive or grooved insulation board
- ④ Insulation Board
- ⑤ Rain Water Leader
- ⑥ Down Spout attachment clamp
- ⑦ Stainless Steel Pipe Sleeve filled with sealant
- ⑧ Stainless Steel Fastener
- ⑨ Neutral Cure Sealant

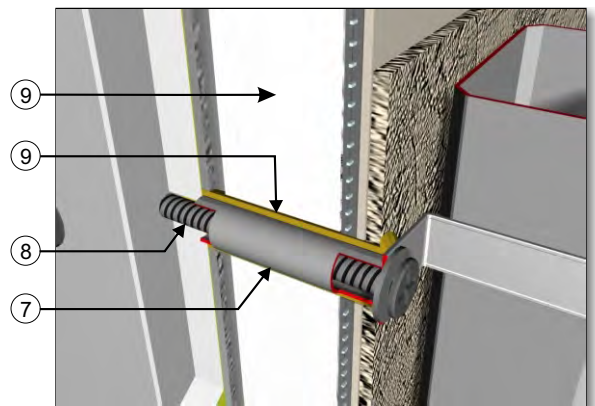

DISCLAIMER:

Any user of this EIFS Practice Manual is expressly bound by the Waiver and Disclaimer set out within this Manual. This illustration is a proprietary component of the EIFS Practice Manual and is subject to full copyright protection."

APPENDIX B: Top 15 EIFS Success Factors

1. Conform to the requirements of the ULC 716 EIFS Standards.
2. Apply materials in accordance with the Manufacturer's published written installation instructions.
3. Use the EIFS quality assurance program and/or other means of third party inspection.
4. Have a pre-construction meeting with all stakeholders.
5. Complete a full mock-up of all details for approval by design authority.
6. Do not substitute materials that are not part of the manufactured EIF system.
7. Don't apply EIFS in the rain/snow or when it's too cold/hot.
8. Don't apply the water resistive barrier (WRB) over poorly prepared substrates.
9. Before attachment of insulation, check that the WRB system is continuous and will drain water at flashings.
10. Periodically remove insulation boards to check for proper adhesion and clear drainage paths.
11. Always use L-shape boards and diagonal reinforcing mesh at openings.
12. Don't align insulation board joints with aesthetic reveals.
13. Encapsulate reinforcing mesh in base coat to proper thickness at all locations (at front, edge and back-wraps).
14. Slope mouldings and trim away from the building.
15. Don't apply finish over base coat at joint surfaces to receive sealants (caulking).

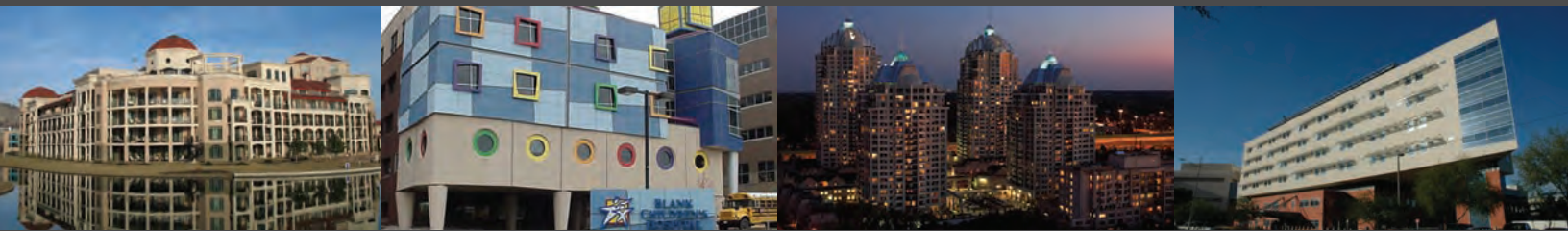

EIFS Council of Canada

70 Leek Crescent

Richmond Hill, ON L4B 1H1

Tel: **416-499-4000**

Fax: 416-499-8752



www.eifscouncil.org